



PRIMA

**Accessori e ricambi
per macchine da stiro e lavasecco**

Accessories and spare parts
for ironing and dry cleaning machines

Accessoires et pièces détachées
pour machines à repasser et nettoyage à sec
Accesorios y recambios de planchas
y máquinas para limpieza en seco

PRIMA

Da oltre 50 anni di presenza sul mercato al servizio di una clientela sempre più vasta e qualificata, rappresenta senza dubbio una solida garanzia di esperienza e professionalità.

Gli sforzi e gli investimenti di questi anni, hanno sempre avuto come obiettivo la pianificazione e la ricerca di nuovi ritrovati atti a migliorare la qualità lavorativa nel campo dello stiro industriale e del lavaggio a secco; anche grazie all'utilizzo di tecnologie sempre più avanzate e alla disponibilità e razionalità nel sistema produttivo.

Obiettivi mirati che qualificano un'azienda e che portano a quel "servizio globale", carta vincente nel mercato degli anni 2000.

Oggi la ditta Prima si propone come azienda in crescita strutturale e qualitativa, sempre più inserita in questa filosofia di lavoro, tesa a soddisfare al meglio le molteplici esigenze che provengono dal mercato nazionale ed internazionale.

We have been on the market for fifty years serving a large number of more and more qualified customers.

During the last years the target of our investments and our efforts was the planning and the research to improve the working quality in the industrial pressing and dry cleaning fields.

We are using the most advanced technology and we can boast now an evergrowing availability and functionality in our marketing system.

The main purpose is to make our firm more and more qualified as to provide to our customers an "all-inclusive" service, a safe card to play on the market in the 2000.

Today, PRIMA SRL is constantly developing its structure and the quality of the products.

We are closely following this growth policy to meet the different requirements of the National and international markets.



Nous sommes sur le marché depuis cinquante ans au service d'un grand nombre de clients de plus en plus qualifiés. Au cours des dernières années la cible de nos investissements et de nos efforts a été la planification et la recherche pour améliorer la qualité du travail dans les domaines industriels de nettoyage et lavage à secs.

Nous utilisons la technologie la plus avancée et nous pouvons nous vanter désormais toujours plus la disponibilité et la fonctionnalité de notre système de commercialisation.

L'objectif principal est de rendre notre entreprise plus en plus qualifiée pour fournir à nos clients un service "tout compris", une carte à jouer en toute sécurité sur le marché dans les années 2000.

Aujourd'hui, PRIMA SRL continue constamment à développer sa structure et la qualité de ses produits. Nous suivons de près cette politique de croissance pour répondre aux différentes exigences des marchés national et internationaux.

Somos en el mercado desde hace cincuenta años al servicio de un gran número de más y más clientes calificados.

Durante los últimos años el blanco de nuestras inversiones y nuestros esfuerzos fue la planificación y la investigación para mejorar la calidad del trabajo en los campos de prensado y secos industriales de limpieza.

Utilizamos la tecnología más avanzada y podemos presumir de ahora cada vez mayor disponibilidad y funcionalidad de nuestro sistema de comercialización.

El objetivo principal es hacer nuestra firma cada vez más cualificado para proporcionar a nuestros clientes un servicio "todo incluido", una tarjeta de seguro para jugar en el mercado en el 2000.

Hoy en día, PRIMA SRL desarrolla constantemente su estructura y la calidad de los productos. Estamos siguiendo de cerca esta política de crecimiento para satisfacer las diferentes necesidades de los mercados nacional e internacionales.



A

Imbottiture e coperture a metraggio
Paddings and covers by lenght
Rembourrages et revêtements à métrage
Muletones, espumas y revestimientos a metraxe

pag 4



B

Rivestimenti ed accessori per tavoli, presse e manichini
Coverings and accessories for pressing tables, machines and dummies
Revêtements et accessoires pour tables, machines et mannequins
Revestimientos y accesorios para mesas de planchar, máquinas y maniquies

pag 20



C

Ferri da stiro e ricambi
Irons and spare parts
Fers à repasser et pièces détachées
Planchas de mano y accesorios

pag 28



D

Tubi e guaine isolanti per collegamenti
Hoses, pipes and insulation sheath for connections
Tuyaux et gaines isolantes pour connexions
Tubos y aislantes para conexiones

pag 70



E

Raccorderia
Pipe fittings
Raccords
Conexiones

pag 78



F

Materiale per impianti
Parts for installation
Pièces pour installations
Piezas para instalaciones

pag 82



G

Ricambi per presse
Spare parts for pressing machines
Pièces détachées pour machines à repasser
Piezas de recambio para máquinas de planchar

pag 92



H

Molle e ricambi
Springs and spare parts
Ressorts et pièces détachées
Muelles y repuestos

pag 94



I

Valvole vapore e ricambi
Steam valves and spare parts
Vannes vapeur et pièces détachées
Válvulas de vapor y repuestos

pag 98



L

Gruppi aria e componenti pneumatici
Air groups and pneumatic parts
Groupes air et composants pneumatiques
Grupos de aire y partes neumaticas

pag 106



M

Guarnizioni
Gaskets
Joints
Guarniciones

pag 112

	<p>N Elettrovalvole e ricambi pag 118 Solenoid valves and spare parts Électrovannes et pièces détachées Electrovalvulas y recambios</p>
	<p>O Caldaie, tavoli e ricambi pag 140 Steam generators, tables and spare parts Chaudières, tables à repasser et pièces détachées Generadores de vapor, mesas de planchar y recambios</p>
	<p>P Ricambi per macchine lavasecco pag 162 Spare parts for dry-cleaning machines Pièces détachées pour machines de nettoyage à sec Recambios para máquinas de lavado a seco</p>
	<p>Q Resistenze e accessori per macchine stiro pag 176 Heating elements and accessories for pressing machines Résistances et accessoires pour machines à repasser Resistencias y accesorios para máquinas de planchar</p>
	<p>R Resistenze e accessori per macchine lavasecco pag 202 Heating elements and accessories for dry-cleaning machines Résistances et accessoires pour machines de nettoyage à sec Resistencias y accesorios para máquinas de lavado a seco</p>
	<p>S Termostati per caldaie e tavoli pag 206 Thermostats for steam generators and tables Thermostats pour chaudières et tables à repasser Termostatos para generadores de vapor y mesas de planchar</p>
	<p>T Pistole, spazzole vaporizzanti e ricambi pag 208 Guns, steaming brushes and spare parts Pistolets, brosses vaporisantes et pièces détachées Pistolas, cepillos vaporisantes y recambios</p>
	<p>U Materiale vario pag 220 Different parts Pièces différentes Partes varias</p>
	<p>V Solette corazzate in PTFE pag 236 Armored PTFE iron shoes Semelles renforcées en PTFE Plantillas en PTFE y aluminio</p>
	<p>Z Solette semplici in PTFE pag 246 PTFE iron shoes Semelles simples en PTFE Plantillas en PTFE sencillas</p>

Ø = mm	diametro - diameter - diamètre - diámetro
ØT = mm	diametro flangia - flange diameter - diamètre bride - diametro brida
GTØ = mm	diametro porta sonda - probe holder diameter - diamètre porte sonde - diametro soporte sonda
L = mm	lunghezza - length - longueur - largo
Δ = mm	lunghezza lato flangia - side length of flange - longueur côté bride - largo lado de brida
F = mm	diametro filo - wire diameter - diamètre fil - diametro alambre
SP = mm	spessore - thickness - épaisseur - espesor
H = mm	larghezza - width - largeur - ancho

Cod.	Descrizione	SP=mm	H=mm
	Mollettone poliestere <i>Polyester padding</i> <i>Molleton polyester</i> <i>Muleton poliester</i>		
A.0010		4	1000
A.0020		6	1000
A.0030		9	1000
A.0040		12	1000
A.0060		4	1300
A.0070		6	1300
A.0080		9	1300
A.0090		12	1300
A.0110		4	1500
A.0120		6	1500
A.0130		9	1500
A.0140		12	1500
A.0160		4	2000
A.0170		6	2000
A.0180		9	2000
A.0190		12	2000
A.0210		9	1100
A.0215		12	1100



	Padding cotone <i>Cotton padding</i> <i>Padding coton</i> <i>Padding algodón</i>		
A.0240		10	1400



	Imbottitura Isolante poliestere metallizzata <i>Insulating polyester padding metalized fabric</i> <i>Tissu isolant polyester metallisé</i> <i>Muleton poliester con aislante metalizado</i>		
A.0260		3	1400



Cod.	Descrizione	Size
	Silicone rau-sik avorio <i>Ivory silicon rau-sik</i> <i>Silicone rau-sik ivoire</i> <i>Silicona rau-sik amarilla</i>	
A.0300		1300x800x4
A.0310		1300x800x6
A.0320		1300x800x10
A.0325		1800x900x4
A.0330		1800x900x6
A.0340		1800x900x10

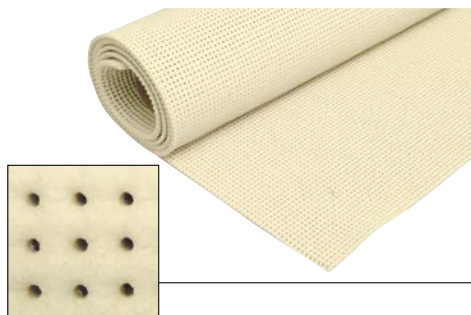

	Silicone rau-sik rosa <i>Pink silicon rau-sik</i> <i>Silicone rau-sik rose</i> <i>Silicona rau-sik rosa</i>	
A.0350		1800x900x6

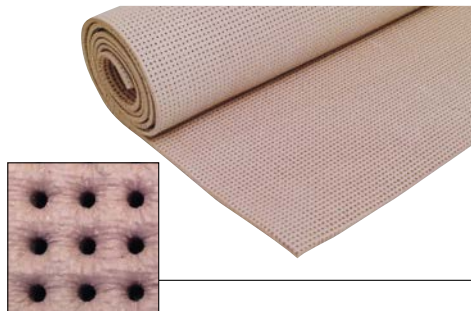

	Silicone rau-sik rosso <i>Red silicon rau-sik</i> <i>Silicone rau-sik rouge</i> <i>Silicona rau-sik rojo</i>	
A.0360		1300x800x10
A.0370		1800x900x10

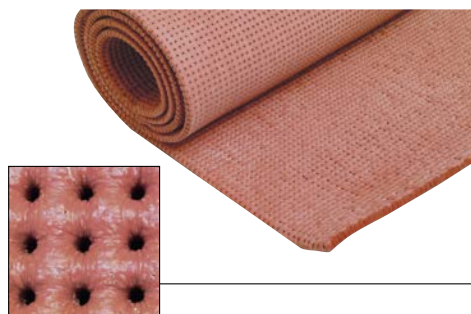

	Silicone per termostampa rosso <i>Red silicon for thermoprinting</i> <i>Silicone rouge pour thermo-collant</i> <i>Silicona para termoestampado rojo</i>	
A.0390		900x600x10
A.0400		1000x1000x10

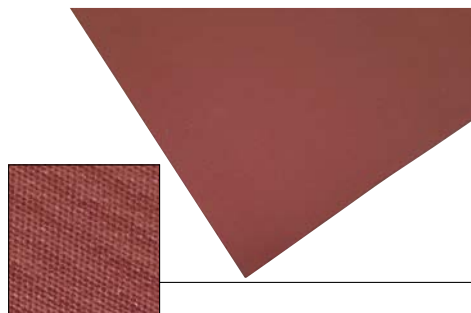

Cod.	Descrizione	SP=mm	H=mm
A.0410	Schiumato per filtri <i>Expanded polyeter dry cleaning filter</i> <i>Mousse pour filtres</i> <i>Espuma para filtros</i>	20	2000x1500

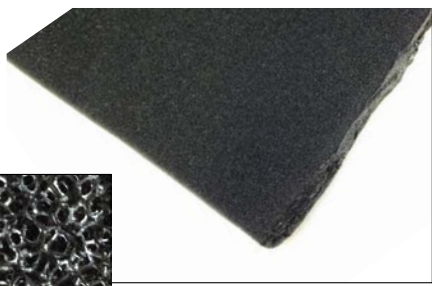

A.0530	Schiumato blu <i>Blue foam</i> <i>Mousse bleu</i> <i>Espuma azul scuro</i>	5	1300
A.0540		7	1300
A.0550		10	1300

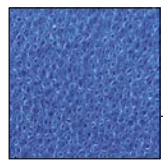
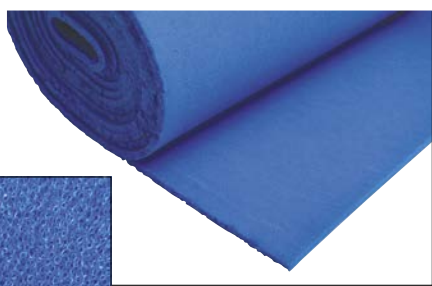

A.0590	Tessuto "3D" bianco (poliestere) <i>White "3D" fabric (polyester)</i> <i>Tissu blanc "3D" (polyester)</i> <i>Tejido blanco "3D" (poliéster)</i>	7	1500
--------	--	---	------



A.0595	Tessuto "3D-3D" bianco (poliestere) <i>White "3D-3D" fabric (polyester)</i> <i>Tissu blanc "3D-3D" (polyester)</i> <i>Tejido blanco "3D-3D" (poliéster)</i>	3	1500
--------	--	---	------



Cod. **Descrizione** **SP=mm** **H=mm**

Silicone schiumato giallo **SOFT**
Yellow silicon foam **SOFT**
Silicone expansé jaune **SOUPLE**
Silicona espumada amarilla **MORBIDA**

A.0600	6	1300
A.0630	8	1300
A.0670	10	1300
A.0710	6	1500
A.0770	10	1500

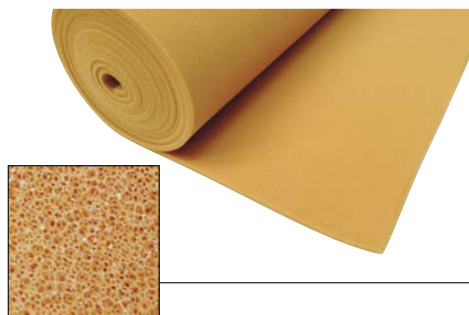

Silicone schiumato blu **HARD**
Blue silicon foam **HARD**
Silicone expansé bleu **RIGIDE**
Silicona espumada azul oscuro **DURA**

A.0610	6	1300
A.0640	8	1300
A.0680	10	1300
A.0720	6	1500
A.0750	8	1500
A.0780	10	1500

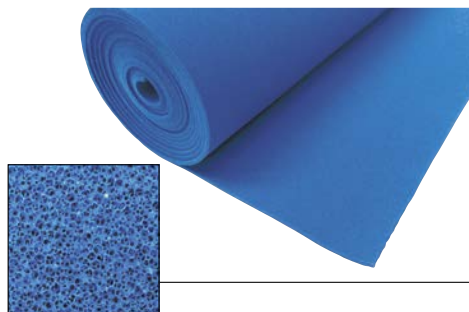

Silicone schiumato azzurro **SUPER HARD**
Blue silicon foam **SUPER HARD**
Silicone expansé bleu **EXTRARIGIDE**
Silicona espumada azul oscuro **EXTRA DURA**

A.0620	6	1300
A.0650	8	1300
A.0690	10	1300
A.0790	10	1500

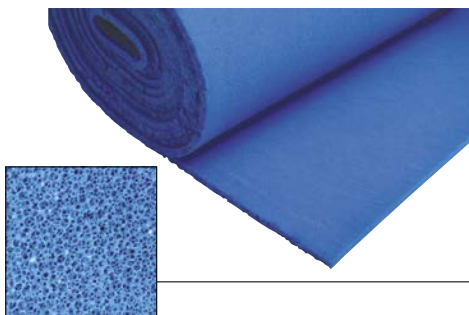

Silicone schiumato arancio **ULTRA SOFT**
Orange silicon foam **ULTRA SOFT**
Silicone expansé orange **ULTRASOUPLE**
Silicona espumada naranja **ULTRA MORBIDA**

A.0665	10	1300
A.0700	15	1300

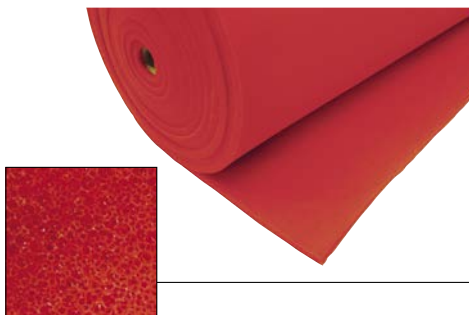

Cod. Descrizione SP=mm H=mm

Silicone schiumato **MICRO PAD LES**
 Silicon foam **MICRO PAD LES**
 Silicone expanse **MICRO PAD LES**
 Silicona espumada **MICRO PAD LES**

A.0795 10 1000

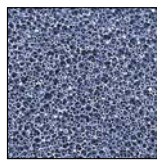
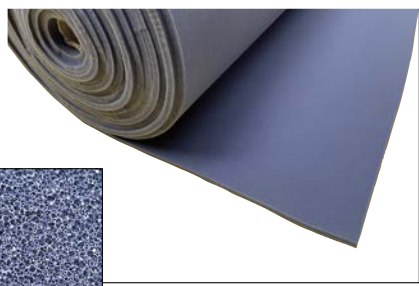

Gommaschiuma grigia
 Grey foam rubber
 Mousse de caoutchouc grise
 Gomaespuma gris

A.0800 7 1400
 A.0810 10 1400
 A.0820 15 1400

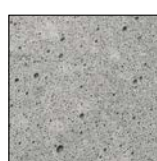

Feltro lana
 Wool felt
 Feutre en laine
 Fieltro lana

A.0900 2 1500
 A.0910 3 1500
 A.0920 5 1500
 A.0930 10 1500
 A.0940 10 1600



Flanella cotone
 Cotton felt
 Flanelle en coton
 Flanelina algodón

A.0950 1,5 700



Cod.	Descrizione	SP=mm	H=mm
	Felpatino cotone <i>Napped cotton felt</i> <i>Feutre en coton</i> <i>Felpatino algodón</i>		
A.1000		2,5	1200
A.1010		2,5	1400
A.1020		2,5	1500
A.1030		2,5	1800



	Felpatino poliester "TM 24" <i>Napped polyester felt "TM 24"</i> <i>Feutre en polyester "TM 24"</i> <i>Felpatino poliester "TM 24"</i>		
A.1040		2	1500



	Felpatino nomex <i>Napped nomex felt</i> <i>Feutre en nomex</i> <i>Felpatino nomex</i>		
A.1058		4	1350
A.1060		4	1800



	Fodera terylene verde (poliester) <i>Green terylene fabric (polyester)</i> <i>Tissu terylene vert (polyester)</i> <i>Tejido rígido terylene verde (poliester)</i>		
A.1100			1600



Cod.	Descrizione	H=mm
A.1110	Fodera terylene azzurra (poliestere) <i>Light blue terylene fabric (polyester)</i> <i>Tissu terylene bleu clair (polyester)</i> <i>Tejido rigido terylene azul (poliester)</i>	1600
A.1120	Fodera terylene bianca (poliestere) <i>White terylene fabric (polyester)</i> <i>Tissu terylene blanc (polyester)</i> <i>Tejido rigido terylene blanco (poliester)</i>	1600
A.1150	Fodera terylene "BL" azzurra (poliestere) <i>Light blue "BL" terylene fabric (polyester)</i> <i>Tissu terylene "BL" bleu clair (polyester)</i> <i>Tejido rigido terylene "BL" azul (poliester)</i>	1500
A.1170	Fodera "Nautica" azzurra (poliestere) scivolosa <i>Light blue "Nautical" fabric (polyester) slippy</i> <i>Tissu bleu clair "Nautical" (polyester) glissant</i> <i>Tejido "Náutica" azul claro (poliéster) deslizante</i>	1550

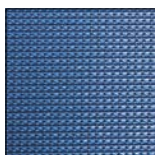
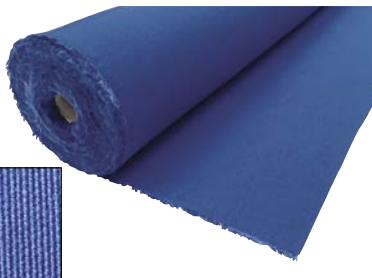
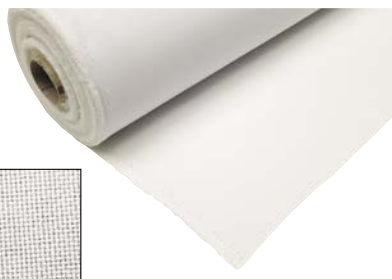
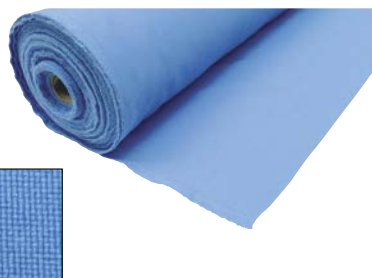

Cod.	Descrizione	H=mm
A.1200	Fodera 35% cotone - 65% poliestere verde Green cotton 35% - polyester 65% fabric Tissu 35% coton - 65% polyester vert Tejido rigido 35% algodón - 65% poliéster verde	1500

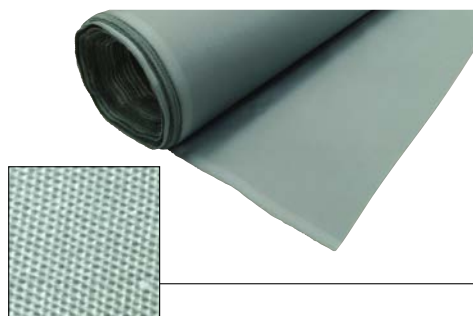

A.1210	Fodera 35% cotone - 65% poliestere azzurra Light blue cotton 35% - polyester 65% fabric Tissu 35% coton - 65% polyester bleu clair Tejido rigido 35% algodón - 65% poliéster azul	1500
--------	--	------

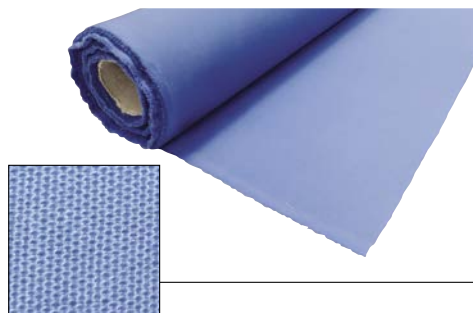

A.1220	Fodera cotone grezza Unbleached cotton fabric Tissu coton grege Tejido rigido algodón natural	1600
--------	--	------



A.1300	Fodera elastica stretch verde (poliestere) Green stretch fabric (polyester) Tissu elastique stretch vert (polyester) Tejido stretch verde (poliester)	1500
--------	--	------



Cod.	Descrizione	H=mm	
A.1310	Fodera elastica stretch azzurra (poliester) <i>Light blue stretch fabric (polyester)</i> <i>Tissu elastique stretch bleu clair (polyester)</i> <i>Tejido stretch azul (poliester)</i>	1500	
A.1320	Fodera elastica stretch bianca (poliester) <i>White stretch fabric (polyester)</i> <i>Tissu elastique stretch blanc (polyester)</i> <i>Tejido stretch blanco (poliester)</i>	1500	
A.1330	Fodera elastica stretch blu (poliester) <i>Dark blue stretch fabric (polyester)</i> <i>Tissu elastique stretch bleu foncé (polyester)</i> <i>Tejido stretch azul oscuro (poliester)</i>	1500	
A.1400	Fodera elastica multistretch bianca <i>White elastic multistretch fabric</i> <i>Tissu elastique multistretch blanc</i> <i>Tejido elastico multistretch blanco</i>	1250	

Cod.	Descrizione	H=mm
	Fodera bi-elastica multistretch bianca <i>White bi-elastic multistretch fabric</i> <i>Tissu bi-elastique multistretch blanc</i> <i>Tejido bi-elastico multistretch blanco</i>	

A.1405

1300



	Fodera nomex verde <i>Green nomex fabric</i> <i>Tissu nomex vert</i> <i>Tejido rigido nomex verde</i>
--	--

A.1410

1600



	Fodera nomex azzurra <i>Light blue nomex fabric</i> <i>Tissu nomex bleu clair</i> <i>Tejido rigido nomex azul</i>
--	--

A.1420

1600



	Fodera nomex bianca <i>White nomex fabric</i> <i>Tissu nomex blanc</i> <i>Tejido rigido nomex blanco</i>
--	---

A.1430

1600



Cod. Descrizione H=mm

A.1500 Fodera dek azzurra
Light blue dek fabric
Tissu dek bleu clair
Tejido dek azul 1500

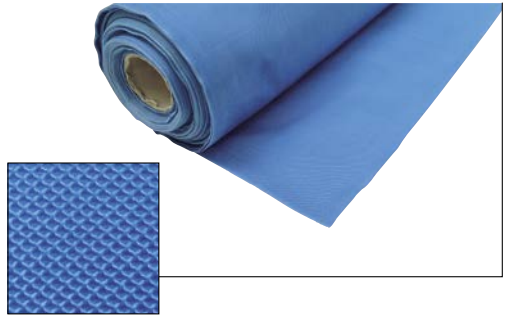

A.1505 Fodera dek blu
Dark blue dek fabric
Tissu dek bleu
Tejido dek azul scuro 1500

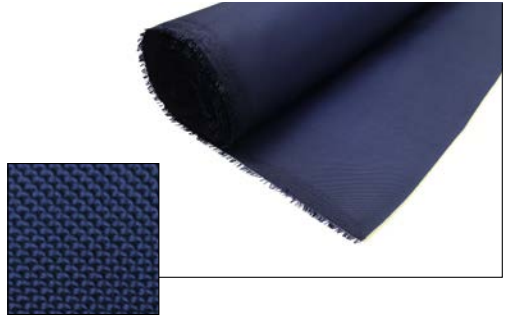

A.1515 Fodera dek verde "tipo Naomoto"
Green dek fabric "type Naomoto"
Tissu dek vert "type Naomoto"
Tejido dek verde "tipo Naomoto" 1500

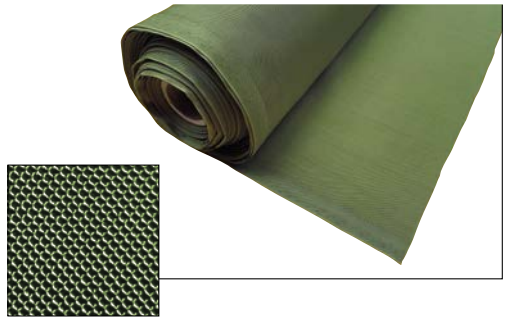

A.1550 Fodera sulon bianca
White polyester sulon fabric
Tissu sulon blanc
Tejido sulon blanco 1600



Cod. **Descrizione** **H=mm**

Tessuto poliestere antilucido milleaghi
Polyester needle fabric
Tissu polyester a aiguilles antilustre
Tejido polyester antifibrillo con agujas

A.1650

1600



Fodera per manichini verde
Green fabric for dummy
Tissu vert pour mannequins
Tejido para maniquies verde

A.1800

1600

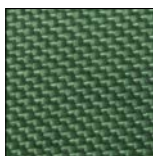

Fodera per manichini azzurra
Light blue fabric for dummy
Tissu bleu clair pour mannequins
Tejido para maniquies azul

A.1810

1600

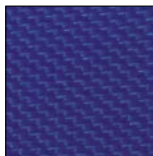

Tessuto tramaordito rigido
Hard fiberglass-ptfe fabric
Tissu fibre de verre-ptfe a grillage rigide
Tejido tramaordimbre rigido

A.1900

1500

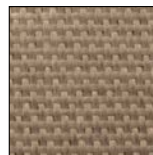

A PRIMA

Rembourages et revêtements
Muebles, espumas y revestimientos

Cod. Descrizione SP=mm H=mm

Tessuto tramaordito morbido
Soft fiberglass-ptfe fabric
Tissu fibre de verre-ptfe a grillage souple
Tejido tramaordimbre morbido

A.1910 1500

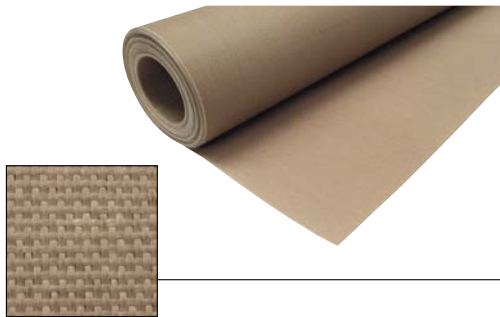

Ptfe cementato adesivo
Adhesive etched ptfe
Ptfe autocollant cimente
Ptfe cementado adhesivo

A.1950 0,5 1000

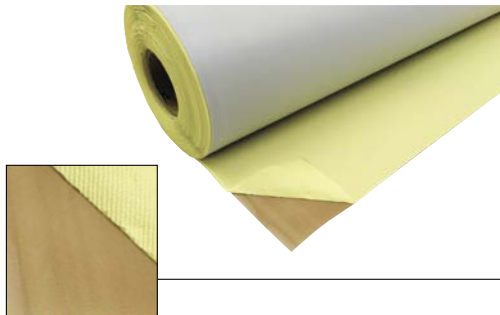

Tessuto fibra di vetro teflonato beige
Beige ptfe fiberglass fabric
Tissu fibre de verre-ptfe beige
Tejido fibra de vidrio teflonado beige

A.2010 0,126 1000
A.2020 0,152 1000
A.2030 0,254 1000
A.2050 0,126 1500
A.2060 0,152 1500

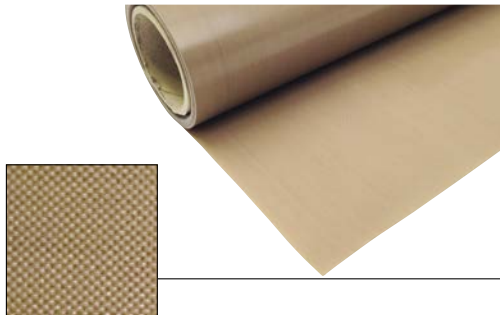

Tessuto fibra di vetro teflonato adesivo beige
Beige adhesive ptfe fiberglass fabric
Tissu fibre de verre-ptfe autocollant beige
Tejido fibra de vidrio teflonado adhesivo beige

A.2110 0,126 1000

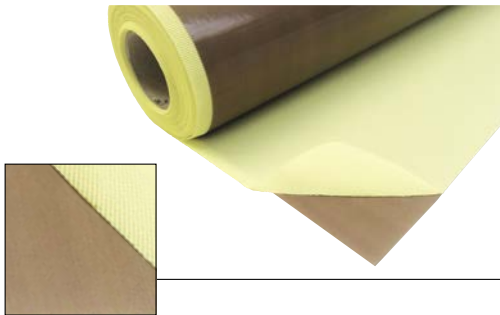

Cod. **Descrizione** **SP=mm** **H=mm**

Tessuto antistatico nero
Black antistatic ptfе fiberglass fabric
Tissu fibre de verre-ptfе antistatique noir
Tejido fibra de vidrio teflonado antiestatico negro

A.2200	0,126	1000
A.2210	0,254	1000
A.2220	0,360	1000
A.2230	0,126	1500
A.2240	0,254	1500
A.2250	0,360	1500

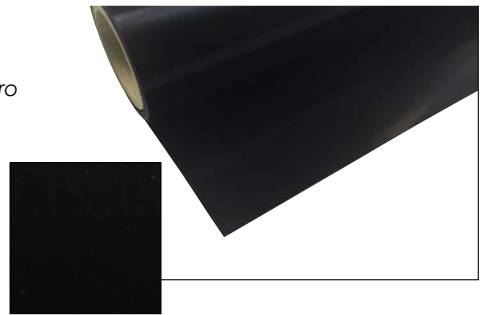

Tessuto antistatico adesivo nero
Black antistatic adhesive ptfе fiberglass fabric
Tissu fibre de verre-ptfе antistatique autocollant noir
Tejido fibra de vidrio teflonado antiestatico adhesivo negro

A.2300	0,126	1000
--------	-------	------

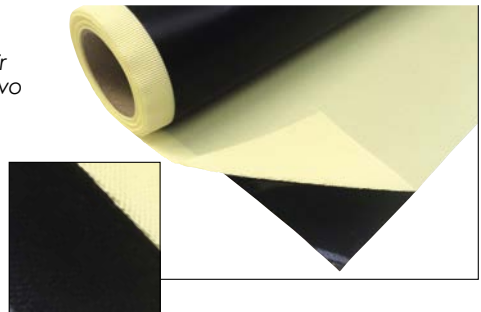

Rete poliestere trama media
Medium-weft polyester gauze
Grillage polyester trame moyenne
Red poliester trama media

A.2400		1500
--------	--	------

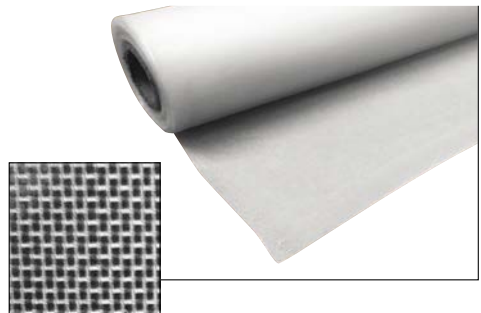

Rete poliestere trama fine
Thin-weft polyester gauze
Grillage polyester trame fine
Red poliester trama fina

A.2410		2150
--------	--	------

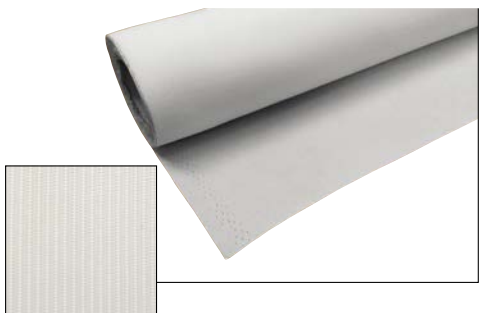

Cod.	Descrizione	H=mm
	Rete poliestere per sacchi secco <i>Dry bags polyester gauze</i> <i>Grillage polyester pour filet a sec</i> <i>Red poliester para saco en seco</i>	

A.2423

1700

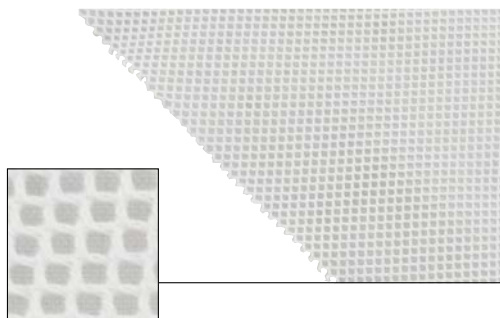

	Rete poliestere per sacchi acqua <i>Water washing bags polyester gauze</i> <i>Grillage polyester pour filet lavage eau</i> <i>Red poliester para saco agua</i>	
--	---	--

A.2425

1850

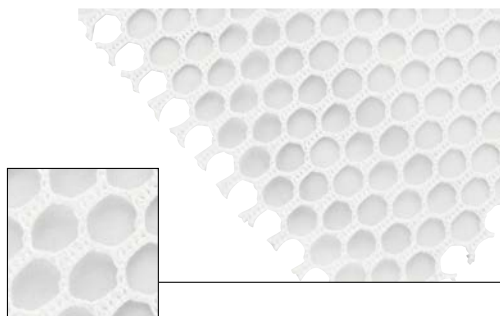

	Rete acciaio zincato <i>Galvanized steel gauze</i> <i>Grillage en acier zingue</i> <i>Red acero zincado</i>	
--	--	--

A.2430

1250



	Rete acciaio zincato trama larga <i>Large-weft galvanized steel gauze</i> <i>Grillage en acier zingue trame large</i> <i>Red acero zincado trama ancha</i>	
--	---	--

A.2450

1250

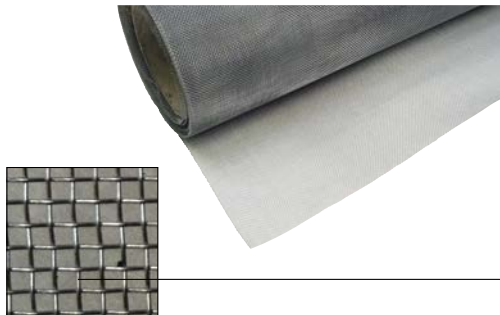

Cod. Descrizione

Rete acciaio inox
 Stainless steel gauze
 Grillage en acier inox
 Red acero inox

		H=mm
A.2500	0,11	1000
A.2510	0,14	1000

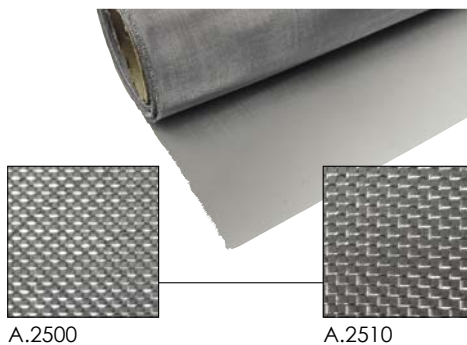

Lamiera alluminio forato
 Drilled aluminium plate
 Plaque aluminium perforée
 Chapa perforada de aluminio

A.2750	2000x1000x0,8mm
--------	-----------------

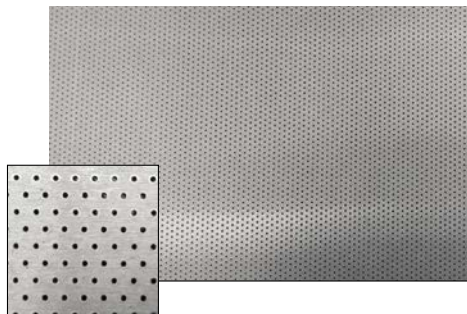

Lamiera alluminio preteflonata
 Aluminium pretefloned plate
 Plaque aluminium preteflonee
 Chapa preteflonada de aluminio

A.2800	1830x800x1mm
--------	--------------

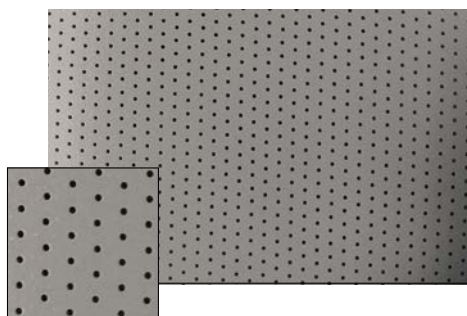

Cod.	Descrizione	L=mm
	Molla tendifodera <i>Spring for cover</i> <i>Ressort pour housse</i> <i>Muelle tensa funda</i>	
B.0010		50
B.0020		100
B.0030		150
B.0040		200
B.0050		250
B.0060		300
B.0070		350
B.0080		500
B.0090		650



B.0210	Gancio "BRETTELLA" per molla tendifodera <i>"BRACES" hook for spring</i> <i>"BRETTELLE" pour ressort de housse</i> <i>"TIRANTE" para muelle tensa funda</i>	
--------	--	--

B.0260	Serie completa molle tendifodera "BRETTELLA" <i>Kit of springs for cover "BRACES HOOKS"</i> <i>Jeu complet de ressorts pour housse "BRETTELLE"</i> <i>Serie completa muelles tensa funda "TIRANTE"</i>	(L=100-150-200mm) 
--------	---	---

B.0300	Cordonetto poliestere 100% <i>100% polyester rope</i> <i>Cordon polyester 100%</i> <i>Cordoncito poliestere 100%</i>	∅ 3mm (300mt) 
--------	---	---

Cod. **Descrizione**

Placca antilucido bacino
Press plate topper
 Plaque antilustre bassin
 Placa antibrillo cajas de pantalon

B.5010

B.999



Placca antilucido universale
Press plate universal
 Plaque antilustre universel
 Placa antibrillo universal

B.5100

C.O.90



Placca antilucido gamba
Press plate leg
 Plaque antilustre jambe
 Placa antibrillo perneras pantalon

B.5110

E.3.O



Placca antilucido
Press plate
 Plaque antilustre
 Placa antibrillo

B.5140
 B.5150

J.1 BOMBATO
 J.1 PIATTO



Imbottiture sagomate a misura
Cut shaped paddings upon demand
Rembourrages coupés sur demande
Recubrimientos segun modelos

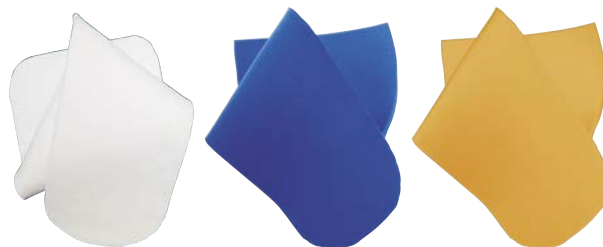

POLYESTER PADDING

FOAM

SILICON

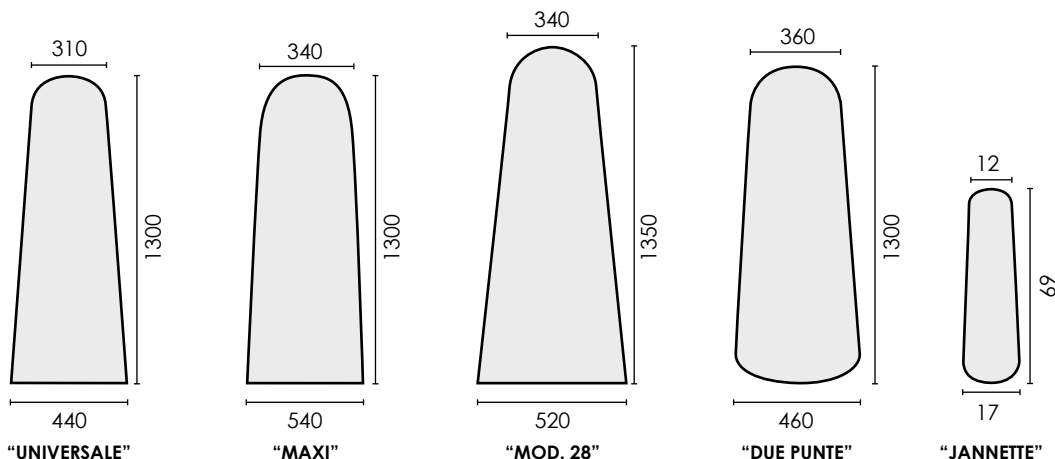

Cod. Descrizione

Cod. Descrizione

Mollettone poliester mod. **"UNIVERSALE"**
"UNIVERSAL" polyester felt
 Molleton polyester mod. *"UNIVERSELLE"*
 Muleton poliester mod. *"UNIVERSAL"*
 B.0400 1300x440x310mm spess. 9mm

Gommaschiuma mod. **"UNIVERSALE"**
"UNIVERSAL" foamed rubber
 Mousse de caoutchouc mod. *"UNIVERSELLE"*
 Gomaespuma mod. *"UNIVERSAL"*
 B.0500 1300x440x310mm spess. 10mm

Mollettone poliester mod. **"MAXI"**
"MAXI" polyester felt
 Molleton polyester mod. *"MAXI"*
 Muleton poliester mod. *"MAXI"*
 B.0410 1300x540x340mm spess. 9mm

Schiumato blu mod. **"UNIVERSALE"**
"UNIVERSAL" blue foam
 Mousse bleu mod. *"UNIVERSELLE"*
 Espuma azul oscuro mod. *"UNIVERSAL"*
 B.0550 1300x440x310mm spess. 10mm

Mollettone poliester mod. **"28"**
"MOD. 28" polyester felt
 Molleton polyester mod. *"MOD. 28"*
 Muleton poliester mod. *"MOD. 28"*
 B.0415 1350x520x340mm spess. 9mm

Schiumato blu mod. **"MAXI"**
"MAXI" blue foam
 Mousse bleu mod. *"MAXI"*
 Espuma azul oscuro mod. *"MAXI"*
 B.0560 1300x540x340mm spess. 10mm

Mollettone poliester mod. **"DUE PUNTE"**
"DOUBLE POINT" polyester felt
 Molleton polyester mod. *"DEUX POINTES"*
 Muleton poliester mod. *"DOS PUNTAS"*
 B.0420 1300x460x360mm spess. 9mm

Schiumato blu mod. **"28"**
"MOD. 28" blue foam
 Mousse bleu *"MOD. 28"*
 Espuma azul oscuro *"MOD. 28"*
 B.0570 1350x520x340mm spess. 10mm

Mollettone poliester mod. **"JEANNETTE"**
"JEANNETTE" polyester felt
 Molleton polyester *"JEANNETTE"*
 Muleton poliester en *"JEANNETTE"*
 B.0430 690x170x120mm spess. 9mm

Silic. Schiumato giallo (soft) mod. **"UNIVERSALE"**
"UNIVERSAL" yellow silicon foam (soft)
 Silicone expanse jaune (souple) mod. *"UNIVERSELLE"*
 Silic. espuma amarilla (soft) mod. *"UNIVERSAL"*
 B.0600 1300x440x310mm spess. 10mm

Si tagliano a misura: mollettone - gommaschiuma - schiumato blu - silicone schiumato
 Upon demand cut all sizes: polyester felt - foamed rubber - blue foam - silicon foam
 Decoupé sur mesure: molleton - mousse de caoutchouc - mousse bleu - silicone expanse
 Se cortan a medida: muleton - gomaespuma gris - espuma azul oscuro - silicona espumada

Cod.

Descrizione

Camiciotto
Cloth for dummy
Housse de mannequin
Funda para maniquie

B.0700 "DALF"
B.0710 "CISSEL GENIE"
B.0720 "CISSEL FADD 10"
B.0730 "GHIDINI - SILC - STIRMAIC"
B.0740 "PONY"
B.0750 "CAMPTTEL MISTRAL"
B.0755 "CAMPTTEL MISTRAL A"
B.0770 "CAMPTTEL 300"
B.0780 "FIBIR"
B.0790 "BM 2000 ROTONDI QAD 1/2"
B.0800 "BM MAXI"
B.0810 "FIMAS 310"



Camiciotto per cabina
Cloth for cabinet
Housse pour cabine
Funda para cabina

B.0760 "CAMPTTEL CABINET"
B.0762 "PONY COSMOS SIDI SIRIO"



Sacco copricamiciotto in rete poliestere 100%
100% polyester gauze over-bag for dummy
Sac en grillage polyester 100% pour housse de mannequin
Saco en red poliester 100% limitador del hinchable

B.0900



Gonna per manichino
Skirt for dummy
Jupe pour mannequin
Falda para hinchable del maniqui

B.0950



Topper
Bag for steam topper
Topper
Tope

B.1000 **GHIDINI - SILC**
B.1010 **CAMPTTEL**
B.1020 **PONY**
B.1030 **CISSEL**



PRIMA

B

Revêtements et accessoires pour tables, machines et mannequins
Revestimientos y accesorios para mesas de planchar, máquinas y maniquies

Teli in tessuto per tavoli e presse stiro
Fabric covers for ironing tables and pressing machines
Housses en tissu pour tables et presses à repasser
Fundas en tejido para mesas y prensas de planchar

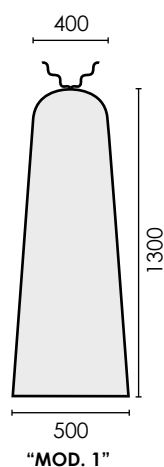

"MOD. 1"

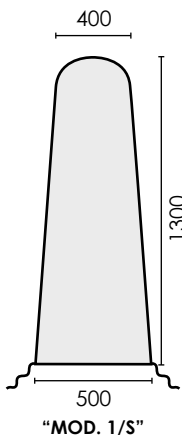

"MOD. 1/S"

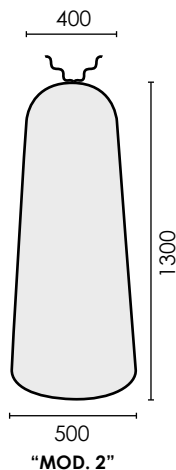

"MOD. 2"

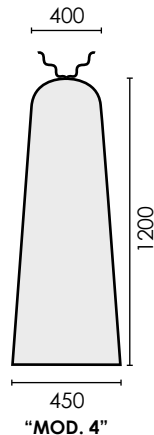

"MOD. 4"

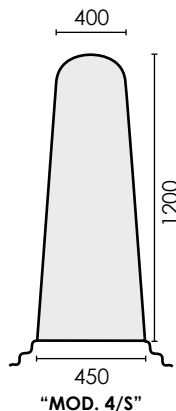

"MOD. 4/S"

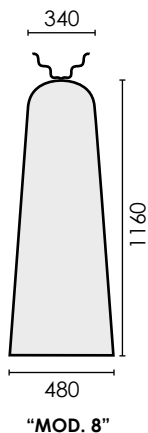

"MOD. 8"

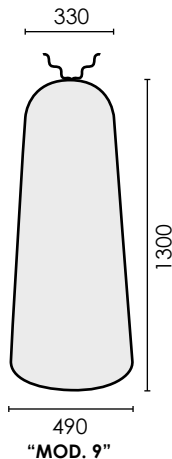

"MOD. 9"

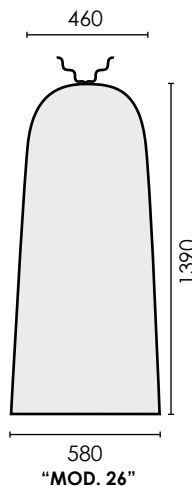

"MOD. 26"

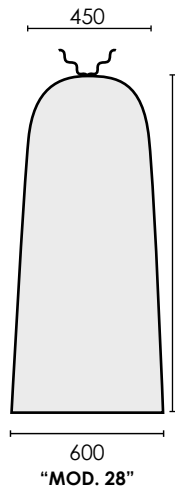

"MOD. 28"

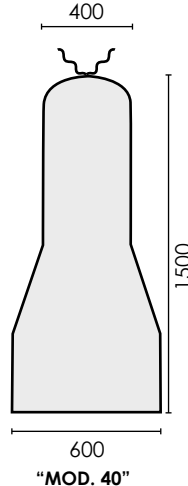

"MOD. 40"

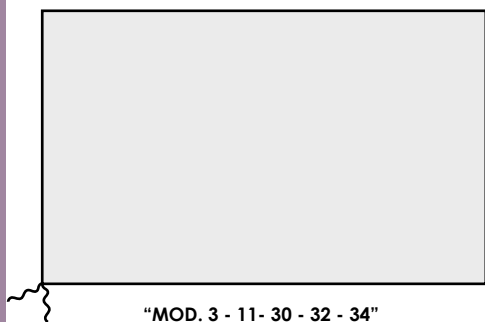

"MOD. 3 - 11 - 30 - 32 - 34"

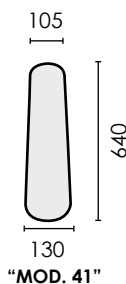

"MOD. 41"

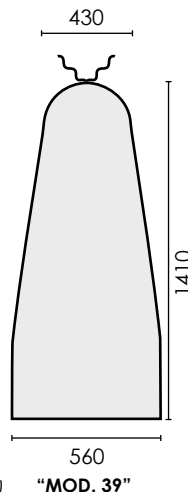

"MOD. 39"

A richiesta teli su misura con qualsiasi tipo di tessuto (prezzi in base a materiale e misure)
Upon demand covers of all sizes, fabrics and colours (prices according to fabrics and sizes)
Housses sur mesure avec tous les tissus (prix selon tissu et dimensions)
Recubrimientos bajo pedido en todo los tipos de tejido y modelos (precios segun tejido y medidas)

Cod. Descrizione

Green terylene cover (polyester)

- B.1500 (mod.1) 1300x500x400mm UNIVERSALE
- B.1510 (mod.1/s) 1300x500x400mm UNIVERSALE post.
- B.1520 (mod.2) 1300x500x400mm DUE PUNTE
- B.1530 (mod.3) 1200x650mm RETTANGOLARE
- B.1540 (mod.4) 1200x450x400mm UNIVERSALE
- B.1550 (mod.4/s) 1200x450x400mm UNIVERSALE post.
- B.1560 (mod.8) 1160x480x340mm PONY FVC
- B.1570 (mod.9) 1300x490x330mm PONY VAPORETTA
- B.1580 (mod.11) 1350x1050mm RETTANGOLARE
- B.1630 (mod.28) 1450x600x450mm MAXI
- B.1640 (mod.30) 1300x800mm RETTANGOLARE
- B.1650 (mod.32) 1400x900mm RETTANGOLARE
- B.1660 (mod.34) 1500x900mm RETTANGOLARE
- B.1670 (mod.39) 1410x560x430mm M.0981



Light blue terylene cover (polyester)

- B.2000 (mod.1) 1300x500x400mm UNIVERSALE
- B.2010 (mod.1/s) 1300x500x400mm UNIVERSALE post.
- B.2020 (mod.2) 1300x500x400mm DUE PUNTE
- B.2030 (mod.3) 1200x650mm RETTANGOLARE
- B.2040 (mod.4) 1200x450x400mm UNIVERSALE
- B.2050 (mod.4/s) 1200x450x400mm UNIVERSALE post.
- B.2060 (mod.8) 1160x480x340mm PONY FVC
- B.2070 (mod.9) 1300x490x330mm PONY VAPORETTA
- B.2080 (mod.11) 1350x1050mm RETTANGOLARE
- B.2092 1170x470x340mm COMELUX
- B.2094 1290x470x360mm COMEL BR/A-FR-F
- B.2096 1400x880mm COMEL MP/A RETTANGOLARE
- B.2120 (mod.26) 1390x580x460mm K52
- B.2130 (mod.28) 1450x600x450mm MAXI
- B.2140 (mod.40) 1500x600x400mm DOB
- B.2150 (mod.41) 640x130x105mm JEANNETTE VEIT
- B.2160 (mod.30) 1300x800mm RETTANGOLARE
- B.2170 (mod.32) 1400x900mm RETTANGOLARE
- B.2180 (mod.34) 1500x900mm RETTANGOLARE
- B.2190 (mod.39) 1410x560x430mm M.0981



Light blue dek cover

- B.2300 (mod.40) 1450x600x330mm DOB
- B.2305 (mod.39) 1410x560x430mm M.0981
- B.2310 (mod.41) 640x130x105mm JEANNETTE VEIT



Green stretch cover

- B.2500 (mod.1) 1300x500x400mm UNIVERSALE
- B.2510 (mod.4) 1200x450x400mm UNIVERSALE



light blue stretch cover

- B.2700 (mod.1) 1300x500x400mm UNIVERSALE
- B.2710 (mod.4) 1200x450x400mm UNIVERSALE



PRONTO-TOP per tavoli e presse stiro
PRONTO-TOP for ironing tables and pressing machines
PRONTO-TOP pour tables et presses à repasser
PRONTO-TOP para mesas y prensas de planchar

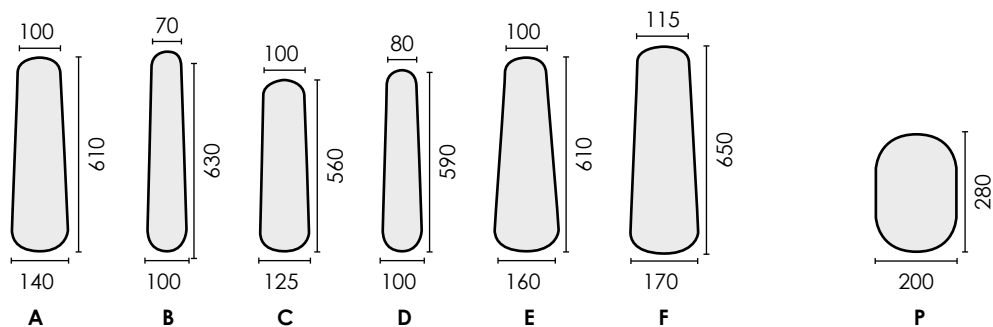
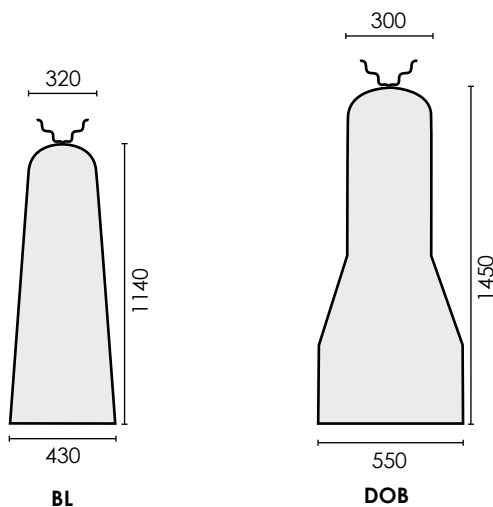
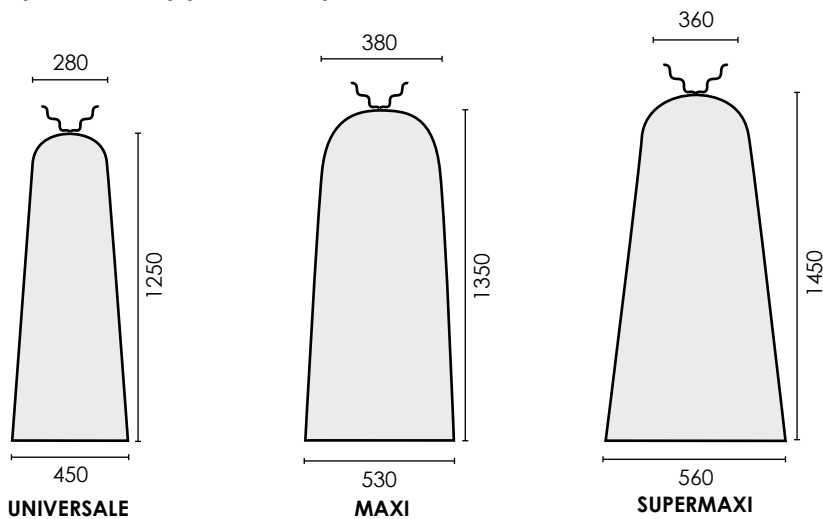

A richiesta **PRONTO-TOP** su misura con qualsiasi tipo di tessuto (prezzi in base a materiale e misure)
Upon demand **PRONTO-TOP** of all sizes, fabrics and colours (prices according to fabrics and sizes)
PRONTO-TOP sur mesure avec tous les tissus (prix selon tissu et dimensions)
PRONTO-TOP bajo pedido en todo los tipos de tejido y modelos (precios según tejido y medidas)

“**NORMALE**”: tessuto poliestere + mollettone spess. 9mm + rete poliestere
 “**REGULAR**”: polyester fabric + polyester felt thick. 9mm + polyester gauze
 “**NORMAL**”: tissu polyester + molleton ép. 9mm + grillage polyester
 “**NORMAL**”: Tejido poliester + muleton espes. 9mm + red poliester

PRONTO-TOP verde “**NORMALE**”
 Green “**REGULAR**” PRONTO-TOP
 PRONTO-TOP verte “**NORMAL**”
 PRONTO-TOP “**NORMAL**” verde

- | | | |
|--------|------------------------------------|-----|
| B.3000 | 1250x450x280mm UNIVERSALE | |
| B.3010 | 1350x530x380mm MAXI | |
| B.3015 | 1450x560x360mm SUPER MAXI | |
| B.3020 | 1140x430x320mm BL | |
| B.3030 | 610x140x100mm BRACCETTO UOMO | (A) |
| B.3040 | 630x100x70mm BRACCETTO DONNA | (B) |
| B.3042 | 560x125x100mm BRACCETTO UOMO | (C) |
| B.3044 | 590x100x80mm BRACCETTO DONNA | (D) |
| B.3046 | 610x160x100mm BRACCETTO UNIVERSALE | (E) |
| B.3048 | 650x170x115mm BRACCETTO GRANDE | (F) |
| B.3050 | 280x200mm PLATONCINO A MANO | (P) |



PRONTO-TOP azzurro “**NORMALE**”
 Light blue “**REGULAR**” PRONTO-TOP
 PRONTO-TOP azur “**NORMALE**”
 PRONTO-TOP “**NORMAL**” azul

- | | | |
|--------|------------------------------------|-----|
| B.3500 | 1250x450x280mm UNIVERSALE | |
| B.3510 | 1350x530x380mm MAXI | |
| B.3515 | 1450x560x360mm SUPER MAXI | |
| B.3520 | 1140x430x320mm BL | |
| B.3525 | 1450x550x300mm DOB | |
| B.3530 | 610x140x100mm BRACCETTO UOMO | (A) |
| B.3540 | 630x100x70mm BRACCETTO DONNA | (B) |
| B.3542 | 560x125x100mm BRACCETTO UOMO | (C) |
| B.3544 | 590x100x80mm BRACCETTO DONNA | (D) |
| B.3546 | 610x160x100mm BRACCETTO UNIVERSALE | (E) |
| B.3548 | 650x170x115mm BRACCETTO GRANDE | (F) |
| B.3550 | 280x200mm PLATONCINO A MANO | (P) |



“**ULTRA**”: tessuto poliestere + spugna spess. 6mm + mollettone spess. 9mm + rete poliestere
 “**ULTRA**”: polyester fabric + foam thick. 6mm + polyester felt thick. 9mm + polyester gauze
 “**ULTRA**”: tissu polyester + mousse ép. 6mm + molleton ép. 9mm + grillage polyester
 “**ULTRA**”: Tejido poliester + espuma espes. 6mm + muleton espes. 9mm + red poliester

PRONTO-TOP verde “**ULTRA**”
 Green “**ULTRA**” PRONTO-TOP
 PRONTO-TOP verte “**ULTRA**”
 PRONTO-TOP “**ULTRA**” verde

- | | | |
|--------|---------------------------|--|
| B.4000 | 1250x450x280mm UNIVERSALE | |
| B.4010 | 1350x530x380mm MAXI | |
| B.4020 | 1450x560x360mm SUPER MAXI | |

PRONTO-TOP azzurro “**ULTRA**”
 Light blue “**ULTRA**” PRONTO-TOP
 PRONTO-TOP azur “**ULTRA**”
 PRONTO-TOP “**ULTRA**” azul

- | | | |
|--------|---------------------------|--|
| B.4500 | 1250x450x280mm UNIVERSALE | |
| B.4510 | 1350x530x380mm MAXI | |
| B.4520 | 1450x560x360mm SUPER MAXI | |



PRIMA

Ferri da stiro e ricambi
Irons and spare parts



ELECTROSTEAM IRONS

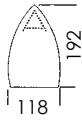

C.0010 V.P. Kg. 1,550



C.0500 (V.P.)



C.2315



C.1100



C.1800



C.1300



C.1420



C.2215



C.1520



C.0510 (V.G.)



C.2810



C.2700



C.2510

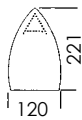

C.0020 V.G. Kg. 1,700

ELECTROSTEAM IRONS

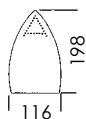

C.0030 STAR P. Kg. 1,400



C.0520 (STAR P.)



C.2330



C.1300



C.1420



C.1600



C.1820



C.4160



C.0530 (STAR G.)



C.2700

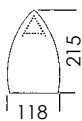

C.0040 STAR G. Kg. 1,500

ELECTROSTEAM IRONS

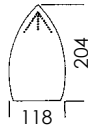

C.0045 IRONMASTER Kg 1,800
 C.0060 IRONMASTER Kg 2
 C.0080 IRONMASTER Kg 3



C.0550



C.1000



C.2000



C.2330



C.2500



C.2750



C.1610



C1800



C.2400



C.2430



C.1300



C.1420

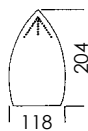

C.0065 IRONMASTER Kg 1,800

ELECTROSTEAM IRONS

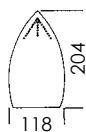

C.0100 IRONMASTER CE Kg. 1,800
C.0102 IRONMASTER CE Kg. 2



C.0550



C.1000



C.2010



C.2520



C.2324



C.1610



C.1900



C.2760



C.1302



C.2424

ELECTROSTEAM IRONS



C.0070 TULIPANO Kg. 1,350



C.0560



C.2010



C.2520



C.2321



C.2760



C.2422



C.1360



C.4000



C.4100



C.1590



C.1640



C.1890



C.4105



C.1400

ELECTROSTEAM IRONS

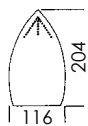

C.0090 JOLLY Kg. 1,750



C.0570



C.2010



C.2520



C.2322



C.2426



C.1620



C.1840



C.4170



C.2760



C.1300

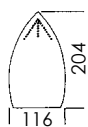

C.0095 JOLLY Kg. 1,750

ELECTROSTEAM IRONS

C.0075 OPEN TULIPANO Kg. 1,350

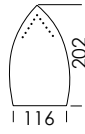

C.0105 OPEN 2F Kg. 1,650

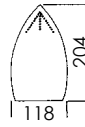

C.0107 OPEN ALL STAR 2F Kg. 1,700

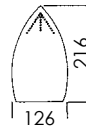

C.0109 OPEN JOLLY Kg. 1,650

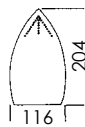

PRIMA



Fers à repasser et pièces détachées
Planchas de mano y accesorios

ELECTROSTEAM IRONS



C.0120 LEMM Kg. 1,550

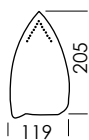

C.0130 LEMM BLACK Kg. 1,550



C.0600



C.1050



C.2030



C.2540



C.4150



C.0610



C.1030



C.2340



C.1580



C.1810



C.1420



C.2420



C.2860



C.4180



C.2415



C.1345



C.1530



C.0620



C.2710



C.2720



C.4132



C.0630



C.0160 MAXI LEMM Kg. 1,800

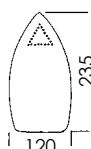

C.0170 MAXI LEMM BLACK Kg. 1,800

ELECTROSTEAM IRONS

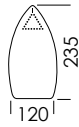

C.0172 MAXI LEMM BRASS Kg. 5,400



C.1810



C.2030



C.2340



C.2540



C.2420



C.2720



C.1050



C.1580



C.4180



C.0190 CISEL ACA 2000 Kg. 1,600



C.0650



C.2010



C.2520



C.2760



C.1640



C.2424



C.1300



C.2330

ELECTROSTEAM IRONS

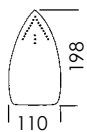

C.0200 MACPI 032 Kg. 1,500



C.0660



C.1070 800W
C.1080 1000W



C.2730



C.1340



C.1570



C.4120



C.1410

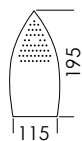

C.0202 NAOMOTO CDP-420 Kg. 1,600



C.2120



C.2130



C.2140



C.4345

ELECTROSTEAM IRONS

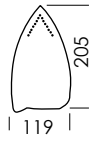

C.0140 H1ENEW Kg. 1,500



C.0600



C.1050



C.1030



C.2710



C.2310



C.1355



C.1580



C.1830



C.0610



C.2720



C.4132

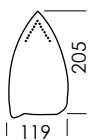

C.0150 H2ENEW Kg. 1,500

ELECTROSTEAM IRONS

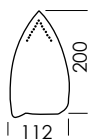

C.0204 TECHNET1 Kg. 1,700



C.0600



C.1050



C.1030



C.1580



C.4132



C.2312



C.2710



C.2720



C.0610



C.1830

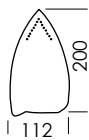

C.0205 TECHNE T5 Kg. 1,700

ELECTROSTEAM IRONS

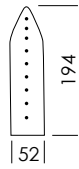

C.0210 APRIPIEGA 2F Kg. 1,200



C.0670



C.2010



C.2326



C.2520



C.1650



C.1300



C.4170



C.2760



C.1850



C.2428

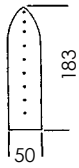

C.0215 FK Kg. 1,300



C.2030



C.2340



C.2540



C.1810



C.2420



C.1420



C.1580

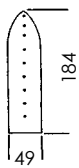

C.0217 LS Kg. 1

ELECTROSTEAM IRONS

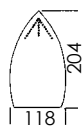

C.0220 IRONMASTER "CE" Kg. 2
NEBULIZER



C.0550



C.1900



C.2520



C.1610



C.1302



C.2322



C.2010



C.2760



C.2424
C.2426



C.2600



C.0570



C.1840



C.1620



C.1300

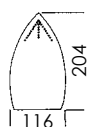

C.0225 JOLLY Kg. 1,750
NEBULIZER

ELECTROSTEAM IRONS

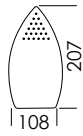

C.0240 TREVIL F022 Kg. 1,600



C.0690



C.1630



C.1870



C.1330



C.2305



C.4110



C.2740

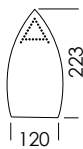

C.0230 LELIT Kg. 1,550



C.0700



C.1370



C.2340



C.1581



C.1855

ELECTROSTEAM IRONS

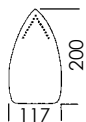

C.0250 721 SMALL Kg. 1,650



C.0710



C.1535



C.2330



C.1100



C.0720



C.4190



C.1302

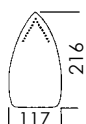

C.0260 721 BIG Kg. 1,750

ELECTROSTEAM IRONS

C.0270 EOS Kg. 1,500



C.0275 REVERBERI 28 Kg. 1,700

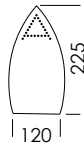

C.0277 STIR MAXI Kg. 1,850

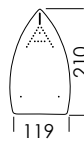

C.0280 PONY SENIOR TT Kg. 1,600

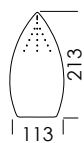

PRIMA



Fers à repasser et pièces détachées
Planchas de mano y accesorios

ELECTRONIC IRONS

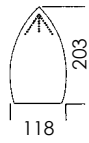

C.0300 2F Kg. 1,600



C.0680



C.4200



C.4210



C.2424



C.1300



C.2760



C.2520



C.4170



C.2322

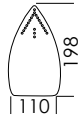

C.0310 MACPI 033 Kg. 1,500



C.1340



C.1410



C.4120



C.1070 800W
C.1080 1000W

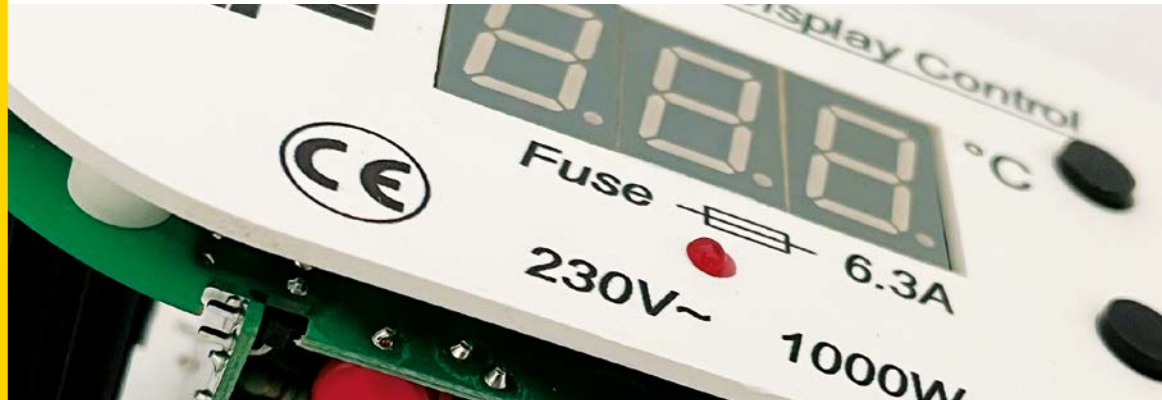

ELECTRIC IRONS

C.0350 Kg. 1,550

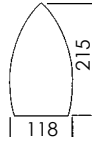

C.0352 IRONMASTER Kg. 3,100

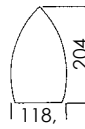

C.0355 MAXI LEMM BRASS Kg. 4,500

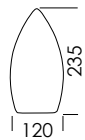

Fers à repasser et pièces détachées
Planchas de mano y accesorios

PRIMA

ALL STEAM IRONS

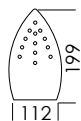

C.0400 ALL STEAM 2F Kg. 1,200

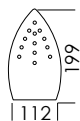

C.0440 OPEN ALL STEAM 2F MONOTUBO Kg. 1,700



C.2040



C.2330



C.2100



C.2110



C.4300

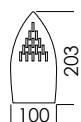

C.0430 ALL STEAM SP-420N Kg. 1,300

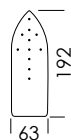

C.0435 ALL STEAM SP-320 Kg. 1



C.4340 SP-420N



C.2150



C.2160



C.4335 SP-320



C.2170 SP-420N



C.2360 SP-420N



C.2380

ALL STEAM IRONS



C.0410
APRICUCITURE ALL STEAM 2F
Kg. 1

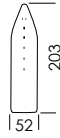

C.0450
OPEN APRICUCITURE ALL STEAM 2F
Kg. 1,100



C.2040



C.2330



C.2100



C.2110



C.4300

Piastra ferro
Plate for iron
Plaque de fer
Base de plancha

- C.0500 V.P. (PROFESSIONAL)
- C.0510 V.G. (PROFESSIONAL BIG)
- C.0520 STAR P.
- C.0530 STAR G.
- C.0550 IRONMASTER
- C.0560 TULIPANO
- C.0570 JOLLY - MASCHIO
- C.0600 LEMM
- C.0610 LEMM (BLACK)
- C.0620 MAXI LEMM
- C.0630 MAXI LEMM (BLACK)
- C.0650 CISEL ACA 2000
- C.0660 MACPI 032
- C.0670 APRIPIEGA 2F
- C.0680 ELETTRONICO 2F
- C.0690 TREVIL F021 - F022
- C.0700 LELIT
- C.0710 721 PICCOLO
- C.0720 721 GRANDE



ACCESSORIES FOR IRONS



C.0800



C.0850



C.0810



C.0820



C.0830



C.0900 SPIRAX TD10 1/4" M.M.



C.0920 MIYAWAKI SL3 1/4" M.F.



C.0950 ST-60J 1/4" M.M.



C.0960 ST-620J 1/4" M. 10ma M.

IRON HEATING ELEMENTS



C.1000 CHROMALOX 800W
C.1010 CHROMALOX 1000W

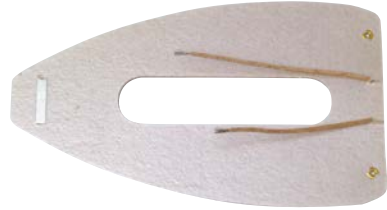

C.1020 MICANITE 800W



C.1030 STIROTECNICA BIELLE 800W



C.1050 STIROTECNICA BIELLE 900 W



C.1070 MACPI 028 - 030 800W
C.1080 MACPI 028 - 030 1000W



C.1100 721 V.P.-V.G. 850W



C.1200 gr.100
C.1210 gr.300

MICROSWITCHES



C.1300 C42ZN



C.1302 C43ZN



C.1310 MS48 PIZZATO



C.1312 MS62 PIZZATO



C.1320 VEIT

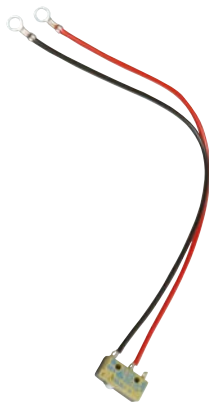

C.1330 TREVIL



C.1340 MACPI 032

MICROSWITCHES



C.1355 H1-H2



C.1345 LEMM NEW
C.1380 EOS



C.1360 TULIPANO



C.1365 OPEN 2F



C.1370 LELIT



C.1375 T1-T5 EC 289



C.1400 TULIPANO



C.1410 MACPI 032



C.1420

THERMOSTATS



C.1500 BIMET



C.1520 V.P. - V.G.
C.1530 LEMM
C.1535 721



C.1540 PONY SENIOR
MACPI 026



C.1560 GHIDINI



C.1570 MACPI 030 - 032



C.1580 LEMM H1-H2
C.1581 LELIT



C.1590 TULIPANO

THERMOSTATS



C.1600 STAR P. - STAR G.



C.1610 IRONMASTER



C.1620 JOLLY - MASCHIO



C.1630 TREVIL



C.1640 TULIPANO



C.1650 APRIPIEGA 2F



C.1660 STIROLUX

SPARE PARTS FOR IRONS

C.1800 STANDARD
 C.1810 LEMM - MACPI 028
 C.1820 STAR P. - STAR G.
 C.1830 H1ENEW - H2ENEW
 C.1840 JOLLY
 C.1850 APRIPIEGA 2F
 C.1855 LELIT
 C.1870 TREVIL
 C.1890 TULIPANO
 C.1900 IRONMASTER "CE"



C.1800



C.1820



C.1840



C.1810



C.1830



C.1850



C.1870



C.1900



C.1855



C.1890

C.2000 IRONMASTER
 C.2010 2F
 C.2030 LEMM
 C.2040 ALL STEAM 2F



C.2000



C.2010



C.2030



C.2040

C.2200 PTFE UNIVERSAL
 C.2205 BISHOMATIC - PONY JUNIOR 2
 C.2215 V.P. - V.G. (PROFESSIONAL)
 C.2220 ALLUMINIUM



C.2200



C.2205



C.2215



C.2220

SPARE PARTS FOR IRONS

ALL STEAM 2F



C.2100



C.2110

NAOMOTO



C.2120



C.2130



C.2140



C.2143

ALL STEAM SP-320 - SP-420N



C.2150



C.2160



C.2170 SP-420N

TREVIL



C.2180

HANDLES

C.2300 TREVIL F005



C.2305 TREVIL F021 - F022



C.2310 H1ENEW - H2ENEW



C.2312 T1 - T5 - EC 289



C.2315 V.P. - V.G. (PROFESSIONAL)



HANDLES

C.2321 TULIPANO
 C.2322 JOLLY
 C.2324 IRONMASTER "CE"
 C.2326 APRIPIEGA 2F



C.2330 STANDARD



C.2340 LEMM



C.2360 SP-420N



C.2380 SP-420N



SPARE PARTS FOR IRONS



C.2400 STANDARD



C.2410 LEFT HAND



C.2415 LEMM (NEW MODEL)



C.2420 LEMM



C.2430 BACK



C.2422 TULIPANO



C.2424 IRONMASTER "CE"
C.2426 JOLLY
C.2428 APRIPIEGA 2F

BACK CONTACTS



C.2500 IRONMASTER



C.2510 V.P.-V.G.



C.2520 2F



C.2540 LEMM

SPARE PARTS FOR IRONS



C.2600 NEBULIZER

- C.2700 STANDARD
- C.2710 STRAIGHT LEMM
- C.2720 CURVED LEMM
- C.2730 MACPI 032
- C.2740 TREVIL
- C.2750 IRONMASTER
- C.2760 2F



C.2800



C.2810



C.2850 3PCS



C.2860 4PCS



C.2900 M. 1/8"



C.2910 M. 1/4"



C.3000



C.2920 M. 1/8"



C.2930 M. 1/4"



C.3500

ELECTRIC CABLES FOR IRONS

Cavo elettrico per microinterruttore
Electrical cable for microswitch
Cable électrique pour microinterrupteur
Cable electrico para microinterruptor

C.3100

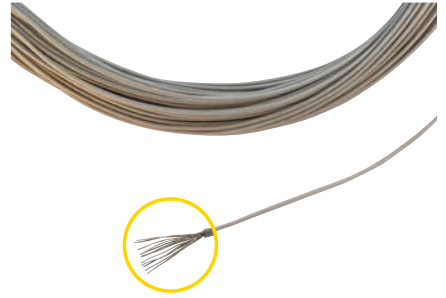

Cavo elettrico stirligato
Fiber glass electric cable
Cable électrique revêtement en fibre de verre
Cable electrico recubierto en fibra de vidrio

C.3110 Ø 1mm
 C.3120 Ø 1,5mm
 C.3130 Ø 2,5mm
 C.3140 Ø 6mm



Cordone elettrico premontato per ferri
Electric cable for irons
Cordon électrique complet pour fers
Cordon electrico premontado para planchas

C.3210 4x1mm L=2300mm



ELECTRIC CABLES FOR IRONS

Cordone elettrico premontato per ferri
Electric cable for iron
 Cordon électrique pour fer
 Cordon electrico para plancha

C.3250
 C.3270

JOLLY - MACPI 073 - PONY JUNIOR 2
 ELETTRONICO 2F 6 fili



C.3250

C.3270

SILICON

Cavo elettrico silicone
Electric silicon cable
 Cable électrique silicone
 Cable electrico de silicona

C.3310 3x1mm
 C.3320 4x1mm
 C.3330 6x0,8mm

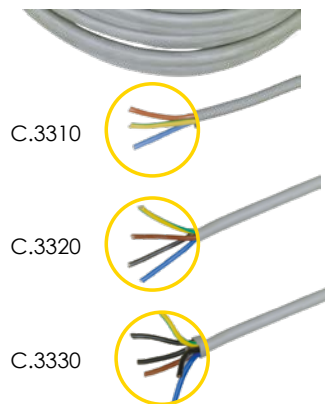

C.3310

C.3320

C.3330

POLYESTER - SILICON

Cavo elettrico terylene-silicone
Polyester-silicon electrical cable
 Cable électrique terylene-silicone
 Cable electrico terylene-silicona

C.3390 4x0,75mm
 C.3400 4x1mm
 C.3430 6x1mm

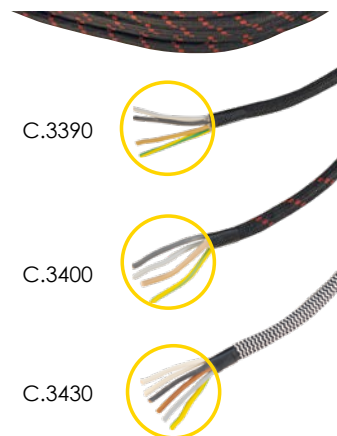

C.3390

C.3400

C.3430

SPARE PARTS FOR IRONS



C.3600



C.3610



C.3700 kg. 1,500 - 2,600



C.3705



C.3710 SIRAFLEX kg. 2 - 3,500



C.3750

IRON HANGERS



C.3770 UNIVERSAL



C.3780 2F



C.3790 2F

ILME



C.3820 PLUG
4 contacts 10A



C.3830 SOCKET
4 contacts 10A



C.3840 CURVED SOCKET
4 contacts 10A

WIELAND



C.3850 PLUG
ST 18/4 15A



C.3860 SOCKET
ST 18/4 15A



C.3870 PLUG
ST 18/6 15A



C.3880 SOCKET
ST 18/6 15A

SPARE PARTS FOR IRONS



C.4100 TULIPANO



C.4105 TULIPANO

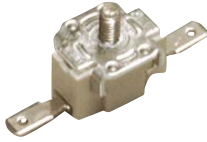

C.4110 TREVIL



C.4120 MACPI 032



C.4132 H1-H2
MACPI 028
MAXI LEMM
T1-T5
EC-289

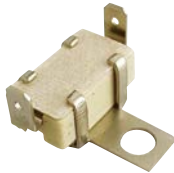

C.4140 VEIT



C.4150 LEMM



C.4160 STAR P. - STAR G.



C.4170 JOLLY - APRIPIEGA 2F - ELETTRONICO 2F

SPARE PARTS FOR IRONS



C.4180 LEMM



C.4190 721



C.4000 FILTER x TULIPANO



C.4200 2F



C.4210 2F



C.4300 ALL STEAM 2F



C.4335 SP-320



C.4330 TREVIL



C.4340 SP-420N



C.4345 NAOMOTO CNP-CDP-HSP

MICROSWITCHES



C.4400 MS05



C.4410 MS09



C.4420 MS10



C.4430 MS15



C.4440 MS30



C.4450 MS32



C.4460 MS35

MICROSWITCHES



C.4470 MS40



C.4480 MS42



C.4490 MS45

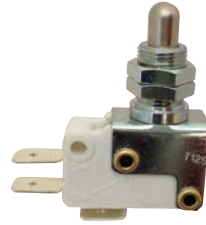

C.4500 ELBI



C.4530 NRI K5



C.4540 NRA44 K5



C.4550 NR31 K5

PRIMA

Tubi ed isolanti per collegamenti
Hoses, pipes and insulation sheath for connections



Cod. Descrizione L=mm R Ø=mm

Tubo pffe calzato raccordato
Pffe hose covered pipe connected
Tuyau pffe avec raccords revetu
Tubo pffe revestido con racors

D.0010		500	F.F. 1/4"	5
D.0020		800	F.F. 1/4"	5
D.0030		1200	F.F. 1/4"	5
D.0040		1400	F.F. 1/4"	5
D.0050		1600	F.F. 1/4"	5
D.0060		1800	F.F. 1/4"	5
D.0070		2000	F.F. 1/4"	5
D.0080		2300	F.F. 1/4"	5
D.0090		2500	F.F. 1/4"	5
D.0100		3000	F.F. 1/4"	5

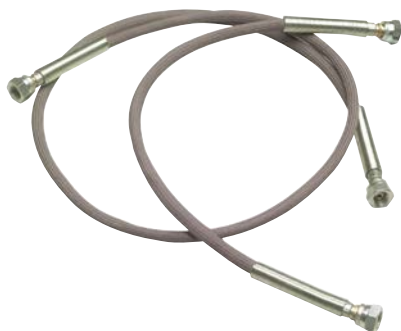

Tubo pffe calzato raccordato NAOMOTO
Pffe hose covered pipe connected NAOMOTO
Tuyau pffe avec raccords revetu NAOMOTO
Tubo pffe revestido con racors NAOMOTO

D.0250		2900	F.F. 1/4" - 3/8"	6
--------	--	------	------------------	---



Tubo pffe recupero condensa ferri NAOMOTO
Pffe hose condense recovery for NAOMOTO irons
Tuyau pffe recuperer condensat pour fers
NAOMOTO
Tubo pffe recobro condensado para planchas
NAOMOTO











D.0260	INNER TUBE			3
--------	------------	--	--	---

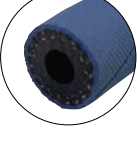

Tubo pffe calzato raccordato
Pffe hose covered pipe connected
Tuyau pffe avec raccords revetu
Tubo pffe revestido con racors

D.0300		2300	F.F. 1/4"	3,5
D.0310		2000	F.F. 1/8"	3,5
D.0320		2300	F.F. 1/8"	3,5
D.0350		1800	F.F. 1/8" - 1/4"	3,2
D.0360		2100	F.F. 1/8" - 1/4"	3,2
D.0370		2500	F.F. 1/8" - 1/4"	3,2



Cod.	Descrizione	R	Ø=mm	
D.0400	Tubo silicone calzato <i>Silicon hose covered</i> <i>Tuyau silicone revetu</i> <i>Tubo de silicona revestido</i>		5x10	 
D.0410	Tubo silicone rinforzato <i>Reinforced silicon hose</i> <i>Tuyau silicone renforce</i> <i>Tubo de silicona reforzado</i>		5x11	 
D.0450	Tubo gomma epdm calzato <i>Epdm rubber hose covered</i> <i>Tuyau caoutchouc epdm revetu</i> <i>Tubo de goma epdm revestido</i>		5x10	 
D.0460	Tubo gomma epdm rinforzato <i>Reinforced epdm rubber hose</i> <i>Tuyau caoutchouc epdm renforce</i> <i>Tubo de goma epdm reforzado</i>		5x12,5	 
D.0500	Tubo ptfе calzato inox <i>Ptfe hose inox covered</i> <i>Tuyau ptfe revetu inox</i> <i>Tubo ptfe revestido inox</i>	3/8"	9	
D.0550	Raccordo completo 3 pezzi per tubo ptfе calzato inox <i>Pipe fittings 3 pcs for ptfe hose inox braiding</i> <i>Raccord complet 3 pieces pour tuyau ptfe revetu inox</i> <i>Union completa 3 piezas para tubo ptfe revestido inox</i>	3/8"		

Cod. Descrizione R Ø=mm

Nipplo conico
Conical nipple
Nipple conique
Niple conico

D.0560
D.0570
D.0580

M.M. 3/8"
M.F. 3/8"
M.M. 3/8" - 1/2"



D.0560

D.0570

D.0580



Tubo ptfе calzato inox
Ptfе hose inox covered
Tuyau ptfе revetu inox
Tubo ptfе revestido inox

D.0700

1/2"

13



Raccordo completo 3 pezzi per tubo ptfе calzato inox
Pipe fittings 3 pcs for ptfе hose inox braiding
Raccord complet 3 pieces pour tuyau ptfе revetu inox
Union completa 3 piezas para tubo ptfе revestido inox

D.0750

1/2"



Nipplo conico
Conical nipple
Nipple conique
Niple conico

D.0760

M.M.1/2"



Tuyaux et gaines isolantes pour connexions
Tubos y aislantes para conexiones

PRIMA

Cod. **Descrizione** **L=mm** **R**

Tubo flessibile ptfе ø 10mm calzato inox
Flexible inox braiding ptfе hose ø 10mm
Tuyau flexible ptfе ø 10mm inox
Tubo flexible ptfе ø 10mm revestido inox

D.1000	300mm	M.F. 3/8"
D.1010	400mm	M.F. 3/8"
D.1020	500mm	M.F. 3/8"
D.1030	600mm	M.F. 3/8"
D.1050	700mm	M.F. 3/8"
D.1060	800mm	M.F. 3/8"
D.1070	900mm	M.F. 3/8"
D.1080	1000mm	M.F. 3/8"
D.1090	1200mm	M.F. 3/8"
D.1100	1500mm	M.F. 3/8"
D.1110	1800mm	M.F. 3/8"
D.1120	2000mm	M.F. 3/8"
D.1130	2500mm	M.F. 3/8"
D.1140	3000mm	M.F. 3/8"



Tubo flessibile ptfе ø 13mm calzato inox
Flexible inox braiding ptfе hose ø 13mm
Tuyau flexible ptfе ø 13mm inox
Tubo flexible ptfе ø 13mm revestido inox

D.1300	300mm	M.F. 1/2"
D.1310	400mm	M.F. 1/2"
D.1320	500mm	M.F. 1/2"
D.1330	600mm	M.F. 1/2"
D.1350	700mm	M.F. 1/2"
D.1360	800mm	M.F. 1/2"
D.1370	900mm	M.F. 1/2"
D.1380	1000mm	M.F. 1/2"
D.1390	1200mm	M.F. 1/2"
D.1400	1500mm	M.F. 1/2"
D.1410	1800mm	M.F. 1/2"
D.1420	2000mm	M.F. 1/2"
D.1430	2500mm	M.F. 1/2"
D.1440	3000mm	M.F. 1/2"



Tubo flessibile ptfе ø 19mm calzato inox
Flexible inox braiding ptfе hose ø 19mm
Tuyau flexible ptfе ø 19mm-inox
Tubo flexible ptfе ø 19mm revestido inox

D.1500	300mm	M.F. 3/4"
D.1505	400mm	M.F. 3/4"
D.1510	500mm	M.F. 3/4"
D.1515	600mm	M.F. 3/4"
D.1525	700mm	M.F. 3/4"
D.1530	800mm	M.F. 3/4"
D.1535	900mm	M.F. 3/4"
D.1540	1000mm	M.F. 3/4"
D.1545	1200mm	M.F. 3/4"
D.1550	1500mm	M.F. 3/4"
D.1555	1800mm	M.F. 3/4"
D.1560	2000mm	M.F. 3/4"
D.1565	2500mm	M.F. 3/4"
D.1570	3000mm	M.F. 3/4"



Cod. **Descrizione** **L=mm** **R**

Tubo flex ptfе ø 10mm calza inox-terylene
 Flex inox-terylene braiding ptfе hose ø 10mm
 Tuyau flex ptfе ø 10mm inox-terylene
 Tubo flex ptfе ø 10mm revestido inox-terylene

D.1600	300mm	M.F. 3/8"
D.1610	400mm	M.F. 3/8"
D.1620	500mm	M.F. 3/8"
D.1630	600mm	M.F. 3/8"
D.1650	700mm	M.F. 3/8"
D.1660	800mm	M.F. 3/8"
D.1670	900mm	M.F. 3/8"
D.1680	1000mm	M.F. 3/8"
D.1690	1200mm	M.F. 3/8"
D.1700	1500mm	M.F. 3/8"
D.1710	1800mm	M.F. 3/8"
D.1720	2000mm	M.F. 3/8"
D.1730	2500mm	M.F. 3/8"
D.1740	3000mm	M.F. 3/8"



Tubo flex ptfе ø 13mm calza inox-terylene
 Flex inox-terylene braiding ptfе hose ø 13mm
 Tuyau flex ptfе ø 13mm inox-terylene
 Tubo flex ptfе ø 13mm revestido inox-terylene

D.1900	300mm	M.F. 1/2"
D.1910	400mm	M.F. 1/2"
D.1920	500mm	M.F. 1/2"
D.1930	600mm	M.F. 1/2"
D.1950	700mm	M.F. 1/2"
D.1960	800mm	M.F. 1/2"
D.1970	900mm	M.F. 1/2"
D.1980	1000mm	M.F. 1/2"
D.1990	1200mm	M.F. 1/2"
D.2000	1500mm	M.F. 1/2"
D.2010	1800mm	M.F. 1/2"
D.2020	2000mm	M.F. 1/2"
D.2030	2500mm	M.F. 1/2"
D.2040	3000mm	M.F. 1/2"



Nipplo conico GAS
 Conical nipple GAS
 Nipple conique GAS
 Niple conico GAS

D.2210	M.M. 1/8"
D.2220	M.M. 1/4"
D.2230	M.M. 3/8"
D.2240	M.M. 1/2"
D.2250	M.M. 3/8"-1/2"
D.2260	M.M. 3/4"
D.2270	M.M. 1"



Tuyaux et gaines isolantes pour connexions
 Tubos y aislantes para conexiones

PRIMA

Cod. Descrizione Ø = mm

Guaina isolante copritubo in terylene
Terylene insulating sheath
Gaine isolante terylene pour tuyau
Funda aislante cubre tubo en terylene

D.2400	10
D.2410	12
D.2420	14 (1/4")
D.2430	18 (3/8")
D.2440	23 (1/2")



Guaina isolante copritubo in fibra di vetro siliconata
Siliconed fiber glass insulating sheath
Gaine isolante en fibre de verre silicone pour tuyau
Funda aislante cubre tubo en fibra de vidrio siliconada

D.2600	3
D.2610	5
D.2620	8
D.2630	10
D.2640	12
D.2650	14
D.2660	16



Guaina isolante copritubo in poliestere metallizzata
Polyester metalized fabric insulating sheath
Gaine isolante en polyester metallisee pour tuyau
Funda aislante cubre tubo en poliestere metalizada

D.2700	22 (1/4")
D.2710	26 (3/8")
D.2720	30 (1/2")
D.2730	36 (3/4")
D.2740	44 (1")



Tubo ptfе per vapore
Steam ptfе hose
Tuyau ptfе pour vapeur
Tubo ptfе para vapor

D.2900	4 - 6
D.2910	6 - 8
D.2920	8 - 10
D.2930	10 - 12



Cod. **Descrizione** **Ø=mm**

Tubo rilsan per aria e acqua
Air - water rilsan hose
Tuyau rilsan pour air et eau
Tubo rilsan para aire y agua



D.3000	4 - 6
D.3010	6 - 8
D.3020	8 - 10
D.3030	10 - 12



Tubo aspirazione leggero
Vacuum pipe light
Tuyau d'aspiration léger
Tubo aspiración ligero

D.3200	40
D.3210	43 (1"1/4)
D.3220	50 (1"1/2)
D.3230	60 (2")
D.3240	80
D.3250	90
D.3260	100



Fascetta stringitubo
Hose clamp
Collier pour tuyau d'aspiration
Abrazadera de bloqueo tubo

D.3600	47 - 67
D.3610	62 - 82
D.3620	93 - 113



D.3600



D.3610



D.3620

Cod.	Descrizione	R	Ø=mm
	Raccordo automatico <i>Push-in fitting</i> <i>Raccord automatique</i> <i>Racor automatico</i>		
E.0010		M. M5	4
E.0020		M. 1/8"	4
E.0030		M. 1/8"	6
E.0040		M. 1/8"	8
E.0050		M. 1/4"	6
E.0060		M. 1/4"	8
E.0070		M. 1/4"	10
E.0080		M. 3/8"	8
E.0090		M. 3/8"	10
E.0100		M. 3/8"	12
E.0110		M. 1/2"	12



Raccordo automatico gomito
Push-in fitting elbow
Raccord automatique coude
Racor automatico de codo

E.0200		M. 1/4"	6
E.0210		M. 3/8"	8



Raccordo per tubo rame
Compression fitting for copper pipe
Raccord pour tube en cuivre
Racor para tubo de cobre

E.0300		M. 1/8"	6
E.0310		M. 1/8"	8
E.0320		M. 1/4"	6
E.0330		M. 1/4"	8
E.0340		M. 3/8"	8
E.0350		M. 3/8"	10
E.0360		M. 3/8"	12
E.0370		M. 1/2"	10
E.0380		M. 1/2"	12



Raccordo gomito per tubo rame
Elbow compression fitting for copper pipe
Raccord coude pour tube en cuivre
Racor de codo para tubo de cobre

E.0500		M. 1/8"	6
E.0510		M. 1/8"	8
E.0520		M. 1/4"	6
E.0530		M. 1/4"	8
E.0540		M. 3/8"	8
E.0550		M. 3/8"	10
E.0560		M. 3/8"	12
E.0570		M. 1/2"	10
E.0580		M. 1/2"	12

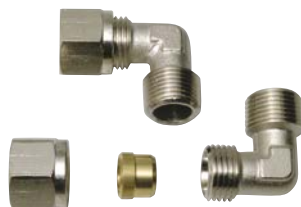

Cod.	Descrizione	R
	Riduzione <i>Adaptor</i> <i>Reducteur</i> <i>Reduccion</i>	
E.1100		M.F. 1/4" - 1/8"
E.1110		M.F. 3/8" - 1/4"
E.1120		M.F. 1/2" - 1/4"
E.1130		M.F. 1/2" - 3/8"



	Manicotto <i>Threaded manifold</i> <i>Embout</i> <i>Manguito</i>	
E.1200		F.F. 1/8"
E.1210		F.F. 1/4"
E.1220		F.F. 3/8"
E.1230		F.F. 1/2"



	Prolunga <i>Extension</i> <i>Rallonge</i> <i>Prolongacion</i>	
E.1300		F.F. 1/8" - 1/4"
E.1310		F.F. 1/4" - 3/8"
E.1320		F.F. 1/4" - 1/2"
E.1330		F.F. 3/8" - 1/2"



	Tappo <i>Cap</i> <i>Bouchon</i> <i>Tapon</i>	
E.1400		M. 1/8"
E.1410		M. 1/4"
E.1420		M. 3/8"
E.1430		M. 1/2"



Cod. **Descrizione** **R**

Raccordo gomito
Elbow fitting
Raccord coude
Racor de codo

E.1500 M.M. 1/8"
E.1510 M.M. 1/8" - 1/4"
E.1520 M.M. 1/4"
E.1530 M.M. 3/8"
E.1540 M.M. 1/2"



Raccordo gomito
Elbow fitting
Raccord coude
Racor de codo

E.1600 M.F. 1/8"
E.1610 M.F. 1/4"
E.1620 M.F. 3/8"
E.1630 M.F. 1/2"



Raccordo gomito
Elbow fitting
Raccord coude
Racor de codo

E.1700 F.F. 1/8"
E.1710 F.F. 1/4"
E.1720 F.F. 3/8"
E.1730 F.F. 1/2"



Raccordo a "T"
"T" fitting
Raccord "T"
Racor a "T"

E.1800 M.M.M. 1/8"
E.1810 M.M.M. 1/4"
E.1820 M.M.M. 3/8"
E.1830 M.M.M. 1/2"

E.1900 F . F . F . 1/8"
E.1910 F . F . F . 1/4"
E.1920 F . F . F . 3/8"
E.1930 F . F . F . 1/2"



Cod.

Descrizione

F.0010	SA 4 1/2"
F.0020	SA 8 1/2"
F.0030	SA 12 1/2"
F.0040	SA 4 3/4"
F.0050	SA 8 3/4"
F.0060	SA 12 3/4"
F.0100	SC 4 1"
F.0110	SC 8 1"
F.0120	SC 12 1"

Scaricatore di condensa a secchiello rovesciato SPIRAX
SPIRAX inverted bucket steam trap
SPIRAX purgeur de condensat a flotteur inverse
SPIRAX purgador de condensados de cubeta invertida

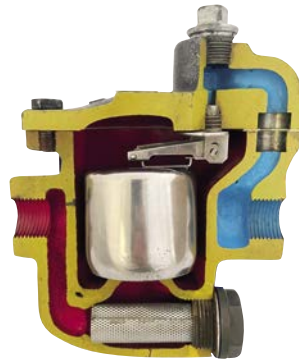

Scaricatore di condensa a secchiello rovesciato
Inverted bucket steam trap
Purgeur de condensat a flotteur inverse
Purgador de condensados de cubeta invertida

F.0070	BT16 1/2"	5,4 bar
F.0072	BT16 1/2"	8,5 bar
F.0074	BT16 1/2"	15,5 bar
F.0080	BT16 3/4"	5,4 bar
F.0082	BT16 3/4"	8,5 bar
F.0084	BT16 3/4"	15,5 bar
F.0090	BT16 1"	5,4 bar
F.0092	BT16 1"	8,5 bar
F.0094	BT16 1"	15,5 bar

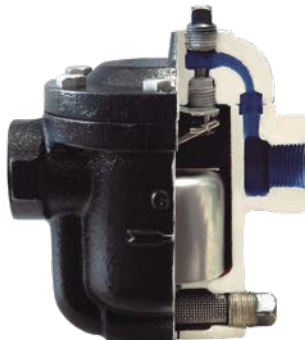

Cod. Descrizione

Scaricatore di condensa a galleggiante SPIRAX
SPIRAX ball float steam trap
SPIRAX purgeur a flotteur ferme
SPIRAX purgador de boya cerrada

F.0150 FT 14-14 R-L PN16 DN15
F.0155 FT 14-14 R-L PN16 DN20
F.0160 FT 14-14 R-L PN16 DN25



Scaricatore di condensa a galleggiante
Ball float steam trap
Purgeur a flotteur ferme
Purgador de boya cerrada

F.0170 SK51 DN15 14 bar
F.0175 SK51 DN20 14 bar
F.0180 SK51 DN25 14 bar



Scaricatore di condensa termodinamico SPIRAX
SPIRAX thermodynamic steam trap
SPIRAX purgeur de condensat thermodynamique
SPIRAX purgador de condensados termodinamico

F.0200 TD 52 3/8"
F.0210 TD 52 1/2"
F.0220 TD 52 3/4"
F.0230 TD 52 1"



Cod.

Descrizione

Scaricatore di condensa termodinamico SPIRAX
 SPIRAX thermodynamic steam trap
 SPIRAX purgeur de condensat thermodynamique
 SPIRAX purgador de condensados termodinamico



F.0250
 F.0260
 F.0270

TD 42 + FILTER 1/2" "L"
 TD 42 + FILTER 3/4" "L"
 TD 42 + FILTER 1" "L"

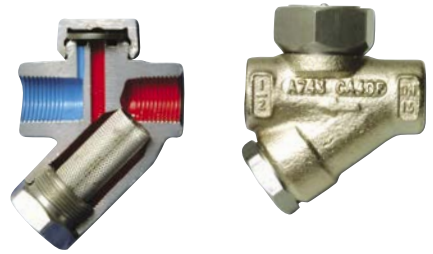

F.0255
 F.0265
 F.0275

TD 42 + FILTER 1/2" "H"
 TD 42 + FILTER 3/4" "H"
 TD 42 + FILTER 1" "H"



Scaricatore di condensa termodinamico
 Thermodynamic steam trap
 Purgeur de condensat thermodynamique
 Purgador de condensados termodinamico



F.0280
 F.0282
 F.0284

TDK45 + FILTER 1/2"
 TDK45 + FILTER 3/4"
 TDK45 + FILTER 1"



Scaricatore di condensa termodinamico
 Thermodynamic steam trap
 Purgeur de condensat thermodynamique
 Purgador de condensados termodinamico



F.0285

TDK71 + FILTER 1/2" INOX



Cod. Descrizione

Scaricatore di condensa termostatico
Thermostatic steam trap
Purgeur de condensat thermostatique
Purgador de condensados termostatico

F.0290 TTK-61 1/2" + FILTER



PRIMA

F

Pièces pour installations
Piezas para instalaciones

Scaricatore di condensa termostatico SPIRAX
SPIRAX thermostatic steam trap
SPIRAX purgeur de condensat thermostatique
SPIRAX purgador de condensados termostatico

F.0300 BPT 13 S 1/2"
 F.0305 BPT 13 S 3/4"

F.0310 BPT 13 SX 1/2" + FILTER
 F.0315 BPT 13 SX 3/4" + FILTER

F.0350 BPT 13 A 1/2"
 F.0360 BPT 13 AX 1/2" + FILTER



F.0300
 F.0305
 F.0310
 F.0315

F.0350
 F.0360

Scaricatore di condensa termostatico
Thermostatic steam trap
Purgeur de condensat thermostatique
Purgador de condensados termostatico

F.0320 TTK-2N + INTEGRATED FILTER 1/2"
 F.0325 TTK-2N + INTEGRATED FILTER 3/4"



Scaricatore di condensa termostatico
Thermostatic steam trap
Purgeur de condensat thermostatique
Purgador de condensados termostatico

F.0330 TTK-2Y + FILTER 1/2
 F.0335 TTK-2Y + FILTER 3/4"



Cod. **Descrizione**

Indicatore di passaggio di condensa bronzo
Bronze flow indicator
Indicateur de passage condensat bronze
Indicador de paso condensado en bronce

F.0800 1/2"



Vetrino per indicatore di passaggio
Glass for flow indicator
Verre de rechange pour indicateur passage de condensat
Vidrio para indicador de paso

F.0810 Ø 50x6mm



Guarnizione per indicatore di passaggio
Gasket for flow indicator
Joint pour indicateur passage de condensat
Guarnicion para indicador de paso

F.0820 Ø 50x2mm HERALDITE
F.0830 Ø 50x1,6mm PTFE



F.0820



F.0830



Indicatore di passaggio condensa bronzo con viti
Bronze flow indicator with screw
Indicateur de passage condensat bronze avec vis
Indicador de paso condensado en bronce con tornillo

F.0850 3/8"
F.0855 1/2"
F.0860 3/4"
F.0865 1"



Cod. Descrizione

Riduttore pressione vapore SPIRAX
 SPIRAX steam pressure reducer
 SPIRAX reducteur de pression vapeur
 SPIRAX reductor de presion vapor

- F.0900 BRV2S 1/2" (3,5 - 8,6 bar)
- F.0910 BRV2S 3/4" (3,5 - 8,6 bar)
- F.0920 BRV2S 1" (3,5 - 8,6 bar)



PRIMA

F

Pièces pour installations
 Piezas para instalaciones

Riduttore pressione vapore
 Steam pressure reducer
 Reducteur de pression vapeur
 Reductor de presion vapor

- F.0980 BDV25 1/2" (3,5 - 8,6 bar)
- F.0985 BDV25 3/4" (3,5 - 8,6 bar)
- F.0990 BDV25 1" (3,5 - 8,6 bar)



Valvola di sicurezza a scarico libero
 Free exhaust safety valve
 Soupape de securite' decharge libre
 Valvula de seguridad a descarga libre

- F.1000 1/4"
- F.1010 3/8"
- F.1020 1/2"
- F.1030 3/4"
- F.1040 1"
- F.1050 1"1/4
- F.1060 1"1/2
- F.1070 2"



Valvola di sicurezza mini (certificata PED)
 Exhaust safety valve mini (PED certified)
 Soupape de securite' mini (certifiée PED)
 Valvula de seguridad mini (certificacion PED)

- F.1100 1/8" 5 bar
- F.1110 1/4" 5 bar
- F.1120 1/4" 7 bar
- F.1130 3/8" 5,5 bar
- F.1140 1/2" 5,5 bar
- F.1150 1/2" 6,5 bar
- F.1160 1/2" 8 bar
- F.1180 3/8" 5 bar COMEL



F.1180



Cod.

Descrizione

Valvola di sicurezza a leva
Exhaust safety valve with lever
Soupape de securite' a levier
Valvula de seguridad con leva

F.1200 1/2"
F.1210 3/4"
F.1220 1"
F.1230 1"1/4
F.1240 1"1/2
F.1250 2"



Valvola di sicurezza a leva (certificata PED)
Exhaust safety valve with lever (PED certified)
Soupape de securite' a levier (certifiée PED)
Valvula de seguridad con leva (certificacion PED)

F.1300 1/2"
F.1310 3/4"
F.1320 1"
F.1330 1"1/4
F.1340 1"1/2
F.1350 2"



Valvola di sicurezza a vite
Exhaust safety valve with screw
Soupape de securite' a vis
Valvula de seguridad con tornillo

F.1400 3/8"
F.1410 1/2"
F.1420 3/4"
F.1430 1"
F.1440 1"1/4
F.1450 1"1/2
F.1460 2"
F.1470 2"1/2
F.1480 3"



Valvola di sicurezza a vite (certificata PED)
Exhaust safety valve with screw (PED certified)
Soupape de securite' a vis (certifiée PED)
Valvula de seguridad con tornillo (certificacion PED)

F.1500 3/8"
F.1510 1/2"
F.1520 3/4"
F.1530 1"
F.1540 1"1/4
F.1550 1"1/2
F.1560 2"
F.1570 2"1/2
F.1580 3"



Cod. Descrizione

Valvola di sicurezza con portagomma
Exhaust safety valve with hose holder
Soupape de securite' avec porte tuyau
Valvula de seguridad con racord tubo

F.1600 M. 1/4"
 F.1610 M. 3/8"
 F.1620 M. 1/2"



PRIMA

F

Pièces pour installations
 Piezas para instalaciones

Valvola di ritegno a clapet
Non-return valve clapet
Soupape de retenue clapet
Valvula de retencion a clapet

F.1700 3/8"
 F.1710 1/2"
 F.1720 3/4"
 F.1730 1"



Valvola di ritegno a clapet pesante
Heavy non-return valve clapet
Soupape de retenue clapet lourd
Valvula de retencion a clapet pesada

F.1800 3/8"
 F.1810 1/2"
 F.1820 3/4"
 F.1830 1"



Valvola di ritegno a clapet pesante
Heavy non-return valve clapet
Soupape de retenue clapet lourd etancheite
Valvula de retencion a clapet pesada

F.1900 3/8" VITON
 F.1910 1/2" VITON



Cod.

Descrizione

Valvola di ritegno EUROPA
Non-return valve EUROPA
Soupape de retenue EUROPA
Valvula de retencion EUROPA

F.2000 3/8"
F.2010 1/2"
F.2020 3/4"
F.2030 1"



Valvola di ritegno ROMA
Non-return valve ROMA
Soupape de retenue ROMA
Valvula de retencion ROMA

F.2100 3/8"
F.2110 1/2"
F.2120 3/4"
F.2130 1"
F.2140 1"1/4
F.2150 1"1/2
F.2160 2"



Valvola di ritegno RJ 205 SPIRAX
SPIRAX non-return valve RJ 205
SPIRAX soupape de retenue RJ 205
SPIRAX valvula de retencion RJ 205

F.2200 3/8"
F.2210 1/2"
F.2220 3/4"
F.2230 1"
F.2240 1"1/4
F.2245 1"1/2
F.2250 2"



Valvola di ritegno
Non-return valve
Soupape de retenue
Valvula de retencion

F.2400 M.M. 1/2" - 1/4"



Cod. Descrizione

Filtro
Filter
Filtre
Filtro

F.2500 1/4"
F.2510 3/8"
F.2520 1/2"
F.2530 3/4"
F.2540 1"



Filtro 12 SG SPIRAX
SPIRAX filter 12 SG
SPIRAX filtre 12 SG
SPIRAX filtro 12 SG

F.2600 1/2"



Valvola a sfera
Ball valve
Soupape a bille
Valvula de esfera

F.2700 1/4"
F.2710 3/8"
F.2720 1/2"
F.2730 3/4"
F.2740 1"
F.2750 1"1/4
F.2760 1"1/2
F.2770 2"
F.2780 2"1/2



Valvola a sfera vapore
Ball valve for steam
Soupape a bille pour vapeur
Valvula de esfera para vapor

F.3000 1/4"
F.3010 3/8"
F.3020 1/2"
F.3030 3/4"
F.3040 1"
F.3050 1"1/4
F.3060 1"1/2
F.3070 2"



F PRIMA

Pièces pour installations
Piezas para instalaciones

Cod.

Descrizione

Valvola aspirazione manuale
Manual suction valve
Soupape d'aspiration manuelle
Valvula de aspiracion manual

G.0600
G.0700

1"1/4
2"



G.0600



G.0700

Fungo per valvola aspirazione manuale
Head manual suction valve
Tete pour soupape d'aspiration manuelle
Cabeza para valvula de aspiracion manual

G.0900
G.0910

1"1/4
2"



G.0900

G.0910

Molla inox per valvola aspirazione manuale
Inox spring for manual suction valve
Ressort inox pour soupape d'aspiration manuelle
Muelle inox para valvula de aspiracion manual

G.0950

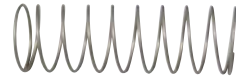

G.0950

Molla inox per valvola aspirazione pneumatica
Inox spring for pneumatic suction valve
Ressort inox pour soupape d'aspiration pneumatique
Muelle inox para valvula de aspiracion neumatica

G.1250

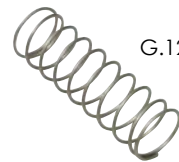

G.1250

Guarnizione ottone per valvola aspirazione
Brass gasket for manual suction valve
Joint en laiton pour soupape d'aspiration
Guarnicion de laton para valvula de aspiracion

G.0960

1"1/4



Cod. Descrizione

Valvola aspirazione pneumatica
Pneumatic suction valve
Soupape d'aspiration pneumatique
Valvula de aspiracion neumatica

G.1000 1"1/4
 G.1100 2"



G.1000

G.1100



Cilindretto coassiale per valvola aspirazione
 pneumatica
Head pneumatic suction valve
Cylindre coaxial pour soupape d'aspiration
pneumatique
Cilindro coaxial de valvula aspiracion neumatica

G.1200 1"1/4
 G.1210 2"



G.1200

G.1210



Paracolpo neoprene
Neoprene buffer
Butoir neoprene
Paragolpe neoprene

M.0800 24/12x11



Guarnizione con distanziale
Gasket with spacer
Joint avec entretoise
Guarnicion con distancial

M.0850 24/12x24



Cod. **Descrizione**

H.0010 Coppia molle per cilindro piccolo
 Couple springs for small cylinder
 Paire de ressorts pour petit cylindre
 Copia muelles para cilindro pequeño

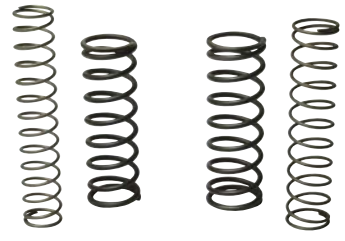

H.0010 H.0020

H.0020 Coppia molle per cilindro grande
 Couple springs for big cylinder
 Paire de ressorts pour grand cylindre
 Copia muelles para cilindro grande

H.0100 Molla pedale pressa HOFFMAN
 Spring foot pedal HOFFMAN
 Ressort pour pedale presse HOFFMAN
 Muelle pedal prensa HOFFMAN

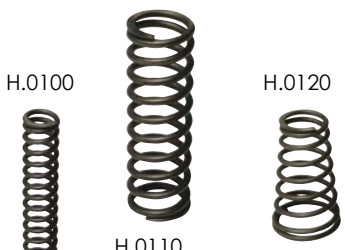

H.0100 H.0110 H.0120

H.0110 Molla pedale centrale pressa HOFFMAN
 Spring central foot pedal HOFFMAN
 Ressort pour pedale centrale presse HOFFMAN
 Muelle pedal central prensa HOFFMAN

H.0120 Molla conica pedale TPRA - ES25
 Conical spring foot pedal TPRA - ES25
 Ressort conique pedale TPRA - ES25
 Muelle conico pedal TPRA - ES25

H.0300 Molla telaio intermedio
 Spring for flapper screen
 Ressort metier intermede
 Muelle para pivote medio



Cod.

Descrizione

Molla richiamo leva 1 gancio pneumatica
1 hook lever return spring - pneumatic
Ressort de rappel levier pneumatique 1 crochet
Muelle de retorno leva 1 gancho neumatica

H.0310

335x21x3mm



Molla richiamo leva 2 ganci manuale
2 hooks lever return spring - manual
Ressort de rappel levier manuel 2 crochets
Muelle de retorno leva 2 ganchos manual

H.0320

330x19x2,5mm



Molla richiamo leva 2 ganci pneumatica
2 hooks lever return spring - pneumatic
Ressort de rappel levier pneumatique 2 crochets
Muelle de retorno leva 2 ganchos neumatica

H.0330

330x20x3mm



Molla con gancio per pressa MAX STIR
MAX STIR hook spring
Ressort avec crochet pour presse MAX STIR
Muelle gancho para prensa MAX STIR

H.0350

210x31x6,5mm



PRIMA

Ressorts et pièces détachées
Muelles y repuestos

Cod. **Descrizione**

Molla MR 70/80
MR 70/80 spring
Ressort MR 70/80
Muelle MR 70/80

H.0410 250x55x6mm



Molla F.6 B23
F.6 B23 spring
Ressort F.6 B23
Muelle F.6 B23

H.0420 200x66x8mm



Molla centrale 29 spire F.6
F.6 29 turn central spring
Ressort central 29 spire F.6
Muelle central 29 espiras F.6

H.0430 250x67x8mm
H.0440 290x65x8,5mm
H.0450 285x66x9mm



Molla laterale C.B.4
C.B.4 lateral spring
Ressort lateral C.B.4
Muelle lateral C.B.4

H.0460 L=300mm 300x40x5mm
H.0470 L=600mm 600x40x5mm



H.0470

H.0460

Cod. Descrizione

Molla F.A.S.
F.A.S. spring
Ressort F.A.S.
Muelle F.A.S.

H.0480 245x56x6mm



Molla C.O.7
C.O.7 spring
Ressort C.O.7
Muelle C.O.7

H.0490 400x31,5x5mm



Molla per maglieria F.6
Spring F.6 for knitting machine
Ressort pour bonneterie F.6
Muelle para maquina de punto F.6

H.0500 600x59x6mm
H.0510 610x65x8,5mm



H.0500

H.0510



Tappo per molla
Cap for spring
Bouchon pour ressort
Tapon para muelle

H.0600 C.O.5
H.0620 MR 70/80
H.0640 F.6
H.0660 C.B.4
H.0680 F.A.S.



H.0620

H.0640

H.0660

H.0600

H.0680



Gancio per tappo molla
Hook for spring cap
Crochet pour bouchon de ressort
Gancho para tapon muelle

H.0700















Tirante per molla
Tension rod for spring
Tirant pour ressort
Tirante para muelle

H.0720



H.0700

H.0720

Cod.	Descrizione			
I.0010	Valvola vapore superiore pneum. cilindretto esagonale <i>Pneumatic upper steam valve exagonal cylinder</i> Vanne vapeur superieure pneumatique cylindre hexagonal Valvula de vapor plato superior neumatica cilindro exagonal			
I.0020	Valvola vapore inferiore pneum. cilindretto esagonale <i>Pneumatic lower steam valve exagonal cylinder</i> Vanne vapeur inferieure pneumatique cylindre hexagonal Valvula de vapor plato inferior neumatica cilindro exagonal			
I.0030				
I.0100	Valvola vapore superiore meccanica <i>Mechanical upper steam valve</i> Vanne vapeur superieure mecanique Valvula de vapor plato superior mecanica			
I.0110	Valvola vapore inferiore meccanica <i>Mechanical lower steam valve</i> Vanne vapeur inferieure mecanique Valvula de vapor plato inferior mecanica			
I.0120				
I.0200	Corpo valvola vapore superiore <i>Upper steam valve casing</i> Corp pour vanne vapeur superieure Cuerpo valvula vapor plato superior			
I.0210	Corpo corto valvola vapore inferiore <i>Lower steam valve short casing</i> Corp court pour vanne vapeur inferieure Cuerpo corto valvula vapor plato inferior	98 mm 	81 mm 	103 mm 
I.0220	Corpo lungo valvola vapore inferiore <i>Lower steam valve long casing</i> Corp long pour vanne vapeur inferieure Cuerpo largo valvula vapor plato inferior	3/4" 	3/4" 	3/4" 

Cod.

Descrizione

Cilindretto esagonale superiore
Upper exagonal cylinder
Cylindre hexagonal superieur
Cilindro exagonal superior

I.0300

"H37"

Cilindretto esagonale inferiore
Lower exagonal cylinder
Cylindre hexagonal inferieur
Cilindro exagonal inferior

I.0310

"P33"

I.0320

"P34"



I.0300
"H37"

I.0310
"P33"

I.0320
"P34"

Cilindretto esclusore con rubinetto per valvola vapore
Exclusory cylinder with tap for steam valve
Cylindre de serrage avec robinet pour vanne vapeur
Cilindro de exclusion con valvula de regulacion vapor

I.0340



Guidaperno completo valvola vapore superiore
Pin guide for upper steam valve
Guide goujon complete pour vanne vapeur superieure
Guia y perno para valvula vapor superior

I.0400

"H37"

Guidaperno completo valvola vapore inferiore
Pin guide for lower steam valve
Guide goujon complete pour vanne vapeur inferieure
Guia y perno para valvula vapor inferior

I.0410

"P33"

I.0420

"P34"



I.0400
"H37"

I.0410
"P33"

I.0420
"P34"









Portadisco valvola vapore
Disk holder for steam valve
Porte joint pour vanne vapeur
Opturador valvula vapor

I.0600



PRIMA

Vannes vapeur et pièces détachées
Válvulas de vapor y repuestos

Cod.	Descrizione		
I.0700 I.0710	Guarnizione ptfè per valvola <i>Ptfe gasket for steam valve</i> <i>Joint ptfe pour vanne vapeur</i> <i>Guarnicion en ptfe para valvula</i>		
	"H37" "P33 - P34"	I.0700	I.0710
I.0800	Molla inox per cilindretto esagonale <i>Inox spring for exagonal cylinder</i> <i>Ressort inox pour cylindre hexagonal</i> <i>Muelle inox para cilindro exagonal</i>		
I.0810	Molla conica con gancio per leva comando valvola meccanica <i>Conical spring with hook for mechanical control lever</i> <i>Ressort conique avec crochet pour poignee</i> <i>Muelle conico con gancho para leva de vaporizacion</i>		
	"H37"	I.0800	I.0810
M.0700	Guarnizione silicone rosso <i>Red silicon gasket</i> <i>Joint silicone rouge</i> <i>Guarnicion silicon rojo</i>		
M.1090	DE 106 S		
	Anello <i>O-ring</i> <i>Anneau</i> <i>Arandela</i>		
	OR 5 SILICONE		

Cod. Descrizione

I.1000 Valvola vapore superiore pneumatica presse PONY - SIDI
Upper pneumatic steam valve for PONY - SIDI machines
Vanne vapeur superieure pneumatique pour presse PONY - SIDI
Valvula vapor neumatica para plato superior prensas PONY - SIDI



I.1050 Valvola vapore inferiore pneumatica presse PONY - SIDI
Lower pneumatic steam valve for PONY - SIDI machines
Vanne vapeur inferieure pneumatique pour presse PONY - SIDI
Valvula vapor neumatica para plato inferior prensas PONY - SIDI

I.1050



I.1100 Valvola vapore superiore meccanica presse PONY - SIDI con leva
Upper mechanical steam valve with lever for PONY - SIDI machines
Vanne vapeur superieure mecanique avec levier presse PONY - SIDI
Valvula vapor mecanica para plato superior con leva prensas PONY - SIDI

I.1100

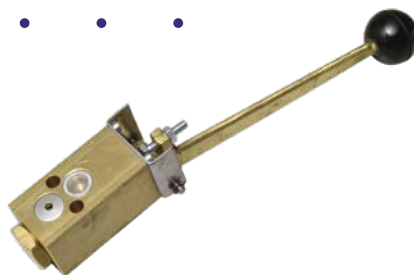

I.1150 Valvola vapore inferiore meccanica presse PONY - SIDI
Lower mechanical steam valve for PONY - SIDI machines
Vanne vapeur inferieure mecanique pour presse PONY - SIDI
Valvula vapor mecanica para plato inferior prensas PONY - SIDI

I.1150

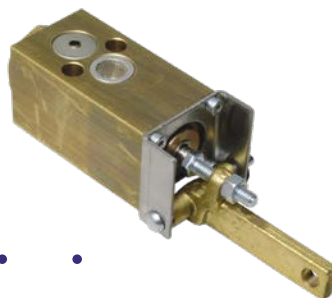

I.1200 Valvola vapore superiore pneumatica pressa CAMPTEL
Upper pneumatic steam valve for CAMPTEL machine
Vanne vapeur superieure pneumatique pour presse CAMPTEL
Valvula vapor neumatica para plato superior prensa CAMPTEL

I.1200

I.1250 Valvola vapore inferiore pneumatica pressa e platine CAMPTEL (tipo vecchio)
Lower pneumatic steam valve for CAMPTEL platine and press (old model)
Vanne vapeur inferieure pneumatique pour platine et presse CAMPTEL (modele vieux)
Valvula vapor neumatica plato inferior platine y prensa CAMPTEL (modelo vejo)

I.1250



Cod.

Descrizione

I.1300
Valvola vapore tavolo vaporizzante e piani inferiori
presse CAMPTEL
Steam valve for CAMPTEL lower press and steaming table
Vanne vapeur pour table vapeur et plateau inferieure
presse CAMPTEL
Valvula vapor mesa vaporizante y plato inferior prensa
CAMPTEL



I.1350
Valvola vapore meccanica tavolo vaporizzante
PONY (tipo vecchio)
Mechanical steam valve for PONY steaming table
(old model)
Vanne vapeur mecanique pour table
vaporisante PONY (modele vieux)
Valvula vapor mecanica para mesa vaporizante
PONY (modelo vejo)

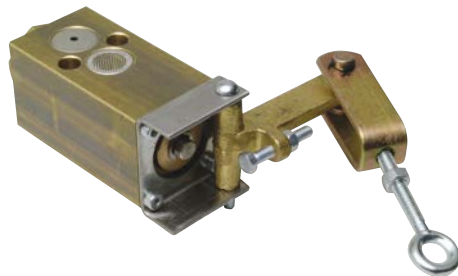

I.1400
Valvola vapore meccanica tavolo vaporizzante
PONY (tipo nuovo)
Mechanical steam valve for PONY steaming table
(new model)
Vanne vapeur mecanique pour table vaporisante
PONY (modele nouveau)
Valvula vapor mecanica para mesa vaporizante
PONY (modelo nuevo)

I.1450
Valvola vapore pneumatica tavolo vaporizzante
PONY (tipo nuovo)
Pneumatic steam valve for PONY steaming table
(new model)
Vanne vapeur pneumatique pour table
vaporisante PONY (modele nouveau)
Valvula vapor neumatica para mesa vaporizante
PONY (modelo nuevo)



I.1500
Valvola vapore meccanica smacchiatore a
caldo PONY "JOLLY S"
Mechanical steam valve for PONY "JOLLY S"
warm spotting
Vanne vapeur mecanique pour detacheur a
chaud PONY "JOLLY S"
Valvula vapor mecanica para desmanchadora
PONY "JOLLY S"



Cod. Descrizione

I.1550
 Valv. Vap. Pneu. cabina e tavolo vapore
 rettang. PONY "COSMOS-PLATINA"
*Pneumatic steam valve for PONY table and
 cabinet "COSMOS - PLATINA"*
*Vanne vapeur pneumatique cabine et table a
 vapeur PONY "COSMOS - PLATINA"*
*Valvula vapor neumatica para cabinet y mesas
 PONY "COSMOS - PLATINA"*



I.1600
 Valvola vapore pneumatica manichino
 stiracamicie PONY
*Pneumatic steam valve for PONY dummy shirt
 finisher*
*Vanne vapeur pneumatique pour mannequin
 de chemises PONY*
*Valvula vapor neumatica para maniqui de
 camisas PONY*

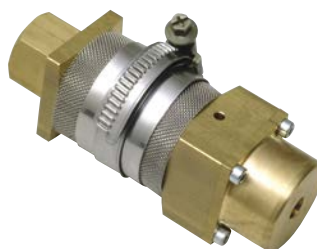

I.1650
 Valvola vapore meccanica manichino PONY
 con caldaia
*Mechanical steam valve for PONY dummy with
 steam generator*
*Vanne vapeur mecanique pour mannequin
 PONY avec chaudiere*
*Valvula vapor mecanica para maniqui PONY
 con caldera*



I.1700
 Valvola vapore pneumatica CAMPTTEL ROTOR
 CABINET (1 via)
*Pneumatic steam valve for CAMPTTEL ROTOR
 CABINET (1 way)*
*Vanne vapeur pneumatique pour CAMPTTEL
 ROTOR CABINET (1 voie)*
*Valvula vapor neumatica para CAMPTTEL ROTOR
 CABINET (1 via)*



I.1750
 Valvola vapore pneumatica CAMPTTEL MISTRAL
 (2 vie)
*Pneumatic steam valve for CAMPTTEL MISTRAL
 (2 ways)*
*Vanne vapeur pneumatique pour CAMPTTEL
 MISTRAL (2 voies)*
*Valvula vapor neumatica para CAMPTTEL MISTRAL
 (2 vias)*

Cod.

Descrizione

Valvola vapore meccanica piani superiori presse
CAMPTEL
*Mechanical steam valve for CAMPTEL presses
heads*
*Vanne vapeur mecanique plateaux superieurs
presses CAMPTEL*
*Valvula vapor mecanica para platos superiores
prensas CAMPTEL*

I.1800



Valvola vapore meccanica tavoli BM
Mechanical steam valve for BM tables
Vanne vapeur mecanique pour tables BM
Valvula vapor mecanica para mesas BM

I.1850



Valvola vapore meccanica tavoli GHIDINI (1 via)
Mechanical steam valve for GHIDINI tables (1 way)
Vanne vapeur mecanique pour tables GHIDINI (1 voie)
Valvula vapor mecanica para mesas GHIDINI (1 via)

I.1900



Valvola vapore meccanica tavoli GHIDINI (2 vie)
Mechanical steam valve for GHIDINI tables (2 ways)
Vanne vapeur mecanique pour tables GHIDINI (2 voies)
Valvula vapor mecanica para mesas GHIDINI (2 vias)

I.1950

Cod. Descrizione

I.2000

Kit ricambio per valvole pneumatiche PONY
Kit of spares for pneumatic steam valve PONY
Jeu de rechange pour vannes pneumatiques PONY
Kit de recambio para valvulas neumaticas PONY



I.2050

Kit ricambio per valvole meccaniche PONY
Kit of spares for mechanical steam valve PONY
Jeu de rechange pour vannes mecaniques PONY
Kit de recambio para valvulas mecanicas PONY



Cod. **Descrizione**

Gruppo filtro lubrificatore
Lubricator - filter set
Unite complete filtre graisseur
Grupo filtro lubrificador

L.0010

1/4"



Filtro regolatore
Regulator - filter
Filtre regulateur
Filtro regulador

L.0020

1/4"



Lubrificatore
Lubricator
Graisseur
Lubrificador

L.0030

1/4"



Gruppo filtro lubrificatore
Lubricator - filter set
Unite complete filtre graisseur
Grupo filtro lubrificador

L.0100

3/8"



Cod. Descrizione

Filtro regolatore
Regulator - filter
Filtre regulateur
Filtro regulador

L.0110 3/8"



Lubrificatore
Lubricator
Graisseur
Lubrificador

L.0120 3/8"



Manometro attacco posteriore
Pressure gauge rear connector
Manometre attache posterieure
Manometro conexion trasera

L.0200 Ø 40mm 1/8" 0 - 6 bar
L.0210 Ø 40mm 1/8" 0 - 12 bar
L.0220 Ø 50mm 1/4" 0 - 6 bar



Manometro attacco posteriore flangiato
Pressure gauge rear flanged connector
Manometre attache posterieure + bride
Manometro conexion trasera con brida

L.0300 Ø 40mm 1/8" 0 - 6 bar
L.0310 Ø 60mm 1/4" 0 - 6 bar
L.0320 Ø 60mm 1/4" 0 - 10 bar



Manometro attacco radiale
Pressure gauge radial connector
Manometre attache radiale
Manometro conexion radial

L.0380 Ø 40mm 1/8" 0 - 6 bar
L.0400 Ø 60mm 1/4" 0 - 6 bar
L.0410 Ø 60mm 1/4" 0 - 10 bar
L.0430 Ø 80mm 1/4" 0 - 10 bar
L.0440 Ø 100mm 3/8" 0 - 10 bar



Cod. Descrizione

Idrometro
Hydrometer
Hydrometre
Hidrometro

L.0490 Ø 40mm 1/4" 0 - 6 bar



Silenziatore
Silencer
Silencieux
Silenciador

L.0500 1/8"
L.0510 1/4"
L.0520 3/8"
L.0530 1/2"
L.0540 3/4"



Valvola scarico rapido
Quick exhaust valve
Soupape de vidange rapide
Valvula descargue rapido

L.0600 1/8"
L.0610 1/4"
L.0620 3/8" - 1/4"
L.0630 1/2"



L.0620

Membrana Vulkollan
Vulkollan membrane
Membrane Vulkollan
Membrana Vulkollan

M.0100 191 1090
M.0110 227 1080
M.0120 32 1090
M.0130 42/75 1080



M.0100 M.0110 M.0120 M.0130

Cod. Descrizione

Disco adiprene per vsc (scarico rapido)
Adiprene disc vsc (quick reducer)
Disque adiprene pour vsc (vidange rapide)
Disco adiprene para vsc (descarga rapida)

M.0600 1/8"
 M.0610 1/4"
 M.0620 1/2"



M.0600 M.0610 M.0620



Valvola unidirezionale
One-way valve
Vanne unidirectionelle
Valvula unidireccional

L.0710 1/4"



Pulsante da pannello
Panel push button
Bouton de panneau
Pulsador de panel

L.0800 2 WAYS 1/8"
 L.0810 3 WAYS 1/8"



Microcomando
Microcontrol
Microcommande
Microcomando

L.0900 2 WAYS 1/8"
 L.0910 3 WAYS 1/8"



L.0900



L.0910

Cod.	Descrizione
	Telecomando <i>Remote control</i> <i>Telecommande</i> <i>Telecomando</i>
L.1000	2 WAYS 1/8"
L.1010	3 WAYS 1/8"
L.1020	3 WAYS 1/8" SMALL



	Comando pneumatico a manopola <i>Pneumatic handle control</i> <i>Commande pneumatique avec poignee</i> <i>Mando neumatico de manopla</i>
L.1100	2 WAYS 1/8"
L.1110	3 WAYS 1/8"



	Comando pneumatico a manopola filettato <i>Pneumatic handle control threaded</i> <i>Commande pneumatique avec poignee filetee</i> <i>Mando neumatico de manopla con rosca</i>
L.1200	2 WAYS 1/8"
L.1210	3 WAYS 1/8"



	Valvola a leva <i>Lever valve</i> <i>Valve avec levier</i> <i>Valvula de leva</i>
L.1400	2 WAYS 1/8"
L.1410	3 WAYS 1/8"





Cod.	Descrizione
M.0100	191 1090
M.0110	227 1080
M.0120	32 1090
M.0130	42/75 1080
M.0150	19/55 1070

Membrana Vulkollan
Vulkollan membrane
Membrane Vulkollan
Membrana Vulkollan

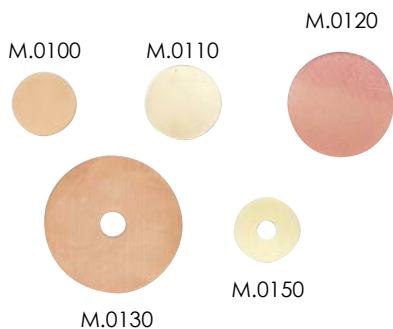

M.0600	1/8"
M.0610	1/4"
M.0620	1/2"

Disco adiprene per vsc (scarico rapido)
Adiprene disc vsc (quick reducer)
Disque adiprene pour vsc (vidange rapide)
Disco adiprene para vsc (descarga rapida)



M.0700	DE 106 S
--------	----------

Guarnizione silicone rosso
Red silicon gasket
Joint silicone rouge
Guarnicion silicon rojo



M.0700

M.0800	24/12x11
--------	----------

Paracolpo neoprene
Neoprene buffer
Butoir neoprene
Paracolpe neoprene



Cod. Descrizione

Guarnizione con distanziale
Gasket with spacer
Joint avec entretoise
Guarnicion con distancial









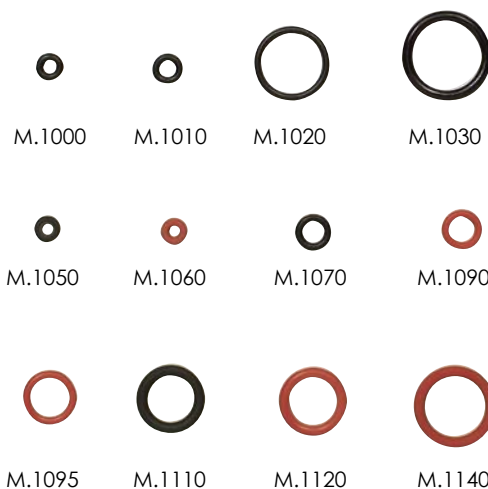



M.0850 24/12x24



Anello
O-ring
Anneau
Arandela

M.1000 2012 NBR
M.1010 2015 NBR
M.1020 2056 NBR
M.1030 OR 121 NBR
M.1050 OR 1 VITON
M.1060 OR 1 SILICON
M.1070 OR 4 VITON
M.1090 OR 5 SILICON
M.1095 OR 7 SILICON
M.1110 OR 9 VITON
M.1120 OR 9 SILICON
M.1140 OR 11 SILICON



Cod.	Descrizione		
M.3000	Guarnizione distillo <i>Gasket distiller</i> <i>Joint distillateur</i> <i>Junta destilador</i> ERCLOR 275x135mm		
M.3010 M.3015	Guarnizione distillo BOWE <i>Gasket BOWE distiller</i> <i>Joint distillateur BOWE</i> <i>Junta destilador BOWE</i> VITON 265x195mm ERCLOR 265x195mm		 M.3010  M.3015
M.3030 M.3035	Guarnizione distillo BOWE <i>Gasket BOWE distiller</i> <i>Joint distillateur BOWE</i> <i>Junta destilador BOWE</i> VITON 238x142mm ERCLOR 238x142mm		 M.3030  M.3035
M.3050 M.3055	Guarnizione tonda oblò distillo BOWE <i>Round gasket for BOWE distiller oblò</i> <i>Joint ronde viton pour oblò distillateur BOWE</i> <i>Junta ronda viton para oblò destilador BOWE</i> VITON 142x118mm ERCLOR 142x118mm		 M.3050  M.3055
M.3070	Guarnizione "U" BOWE <i>"U" gasket for BOWE</i> <i>Joint "U" pour BOWE</i> <i>Junta "U" para BOWE</i> VITON 125x100mm		

Cod.**Descrizione**

Guarnizione oblò RENZACCI
 Gasket for oblò RENZACCI
 Joint ronde pour oblò RENZACCI
 Junta ronda para oblò RENZACCI

M.3100

ERCLOR

Ø 500mm

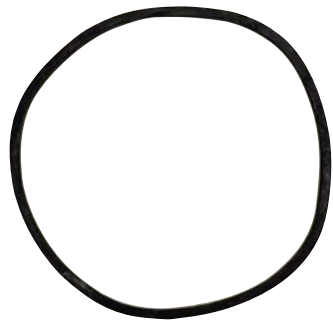
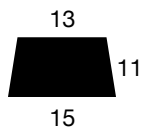

Guarnizione distillo RENZACCI
 Gasket for distiller RENZACCI
 Joint pour distillateur RENZACCI
 Junta para destilador RENZACCI

M.3110

ERCLOR

Ø 245mm



Guarnizione oblò FIRBIMATIC
 Gasket for oblò FIRBIMATIC
 Joint ronde pour oblò FIRBIMATIC
 Junta ronda para oblò FIRBIMATIC

M.3150

ERCLOR

Ø 500mm

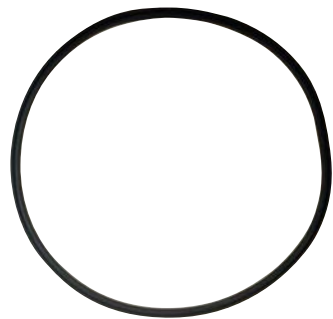
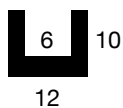

Guarnizione distillo FIRBIMATIC
 Gasket for distiller FIRBIMATIC
 Joint pour distillateur FIRBIMATIC
 Junta para destilador FIRBIMATIC

M.3155

VITON

Ø 280mm

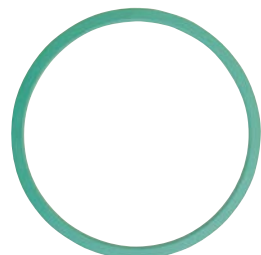

Cod. **Descrizione**

Guarnizione distillo FIRBIMATIC
 Gasket for distiller FIRBIMATIC
 Joint pour distillateur FIRBIMATIC
 Junta para destilador FIRBIMATIC

M.3160 VITON Ø 350mm

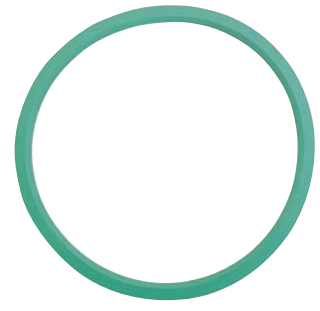
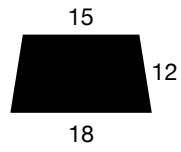

Guarnizione vetro FIRBIMATIC
 Gasket for glass FIRBIMATIC
 Joint pour verre FIRBIMATIC
 Junta para vidrio FIRBIMATIC

M.3165 ERCLOR Ø 150 mm

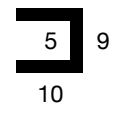

Guarnizione vetro FIRBIMATIC
 Gasket for glass FIRBIMATIC
 Joint pour verre FIRBIMATIC
 Junta para vidrio FIRBIMATIC

M.3170 VITON Ø 150 mm

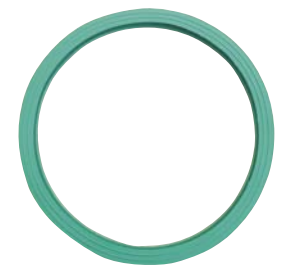
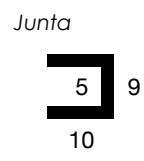

Guarnizione vetro FIRBIMATIC
 Gasket for glass FIRBIMATIC
 Joint pour verre FIRBIMATIC
 Junta para vidrio FIRBIMATIC

M.3175 ERCLOR Ø 210 mm

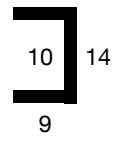

Cod. Descrizione

Guarnizione LSP
LSP gasket
Joint LSP
Junta LSP

M.3200 10x12mm
M.3205 10x15mm
M.3210 10x20mm
M.3220 12x15mm
M.3230 25x30mm



Guarnizione ERCLOR
ERCLOR gasket
Joint ERCLOR
Junta ERCLOR

M.3300 6x6mm
M.3310 10x8mm
M.3320 10x10mm
M.3330 12x10mm
M.3340 12x12mm
M.3350 14x10mm
M.3360 14x14mm



Guarnizione VITON
VITON gasket
Joint VITON
Junta VITON

M.3400 10x8mm
M.3410 10x10mm
M.3420 12x10mm
M.3430 12x12mm
M.3440 14x10mm
M.3450 14x14mm



Guarnizione NBR
NBR gasket
Joint NBR
Junta NBR

M.3500 Ø 5mm

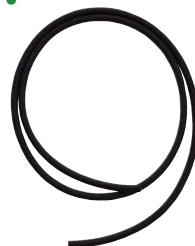

Corda teflonata
Tefloned rope
Corde teflonee
Cuerda teflonada

M.3600 10x10mm
M.3610 12x12mm



Cod.	Descrizione
N.0010	Elettrovalvola vapore CEME <i>Steam solenoid valve CEME</i> <i>Electrovanne vapeur CEME</i> <i>Electrovalvula vapor CEME</i> 1/8" 230V (5522) Ø 2mm
N.0020	Elettrovalvola vapore CEME angolo <i>Steam solenoid valve CEME elbow</i> <i>Electrovanne vapeur CEME angle</i> <i>Electrovalvula vapor CEME en angulo</i> 1/8" 230V (5523) Ø 2mm
N.0050	Elettrovalvola vapore CEME con regolazione <i>Steam solenoid valve CEME with regulation</i> <i>Electrovanne vapeur CEME avec reglage</i> <i>Electrovalvula vapor CEME con regulacion</i> 1/4" 230V (6660) Ø 3mm
N.0060	Elettrovalvola acqua CEME <i>Water solenoid valve CEME</i> <i>Electrovanne eau CEME</i> <i>Electrovalvula agua CEME</i> 1/4" 230V (6712) Ø 2,8mm
N.0065	1/4" 24V (6712) Ø 2,8mm
N.0070	1/4" 230V (6712) VITON Ø 2,8mm
N.0075	1/4" 24V (6712) VITON Ø 2,8mm



Cod. **Descrizione**

Elettrovalvola vapore CEME con regolazione
Steam solenoid valve CEME with regulation
Electrovanne vapeur CEME avec réglage
Electrovalvula vapor CEME con regulacion

N.0100 1/4" 230V (9922) Ø 2,8mm
 N.0110 1/4" 24V (9922) Ø 2,8mm

N.0120 1/4" 230V (9922) PTFE Ø 2,8mm
 N.0130 1/4" 24V (9922) PTFE Ø 2,8mm

N.0150 1/4" 24V (9922) RULON Ø 5,5mm



Elettrovalvola vapore CEME con regolazione
Steam solenoid valve CEME with regulation
Electrovanne vapeur CEME avec réglage
Electrovalvula vapor CEME con regulacion

N.0200 1/4" 230V (9934) Ø 2,8mm
 N.0210 1/4" 24V (9934) Ø 2,8mm



Elettrovalvola vapore CEME
Steam solenoid valve CEME
Electrovanne vapeur CEME
Electrovalvula vapor CEME

N.0240 1/4" 230V (6610) VITON Ø 4mm
 N.0245 1/4" 24V (6610) VITON Ø 4mm



Elettrovalvola acqua CEME
Water solenoid valve CEME
Electrovanne eau CEME
Electrovalvula agua CEME

N.0250 1/4" 230V (9312) Ø 3,5mm
 N.0255 1/4" 24V (9312) Ø 3,5mm

N.0260 3/8" 230V (9313) Ø 3,5mm
 N.0265 3/8" 24V (9313) Ø 3,5mm

N.0270 1/2" 230V (9314) Ø 3,5mm
 N.0275 1/2" 24V (9314) Ø 3,5mm



Cod.

Descrizione

Elettrovalvola vapore CEME
Steam solenoid valve CEME
Electrovanne vapeur CEME
Electrovalvula vapor CEME

N.0300 1/4" 230V (9912) Ø 2,8mm
N.0310 1/4" 24V (9912) Ø 2,8mm

N.0320 3/8" 230V (9913) Ø 3,5mm
N.0330 3/8" 24V (9913) Ø 3,5mm

N.0340 1/2" 230V (9914) Ø 5,5mm
N.0350 1/2" 24V (9914) Ø 5,5mm



Elettrovalvola acqua CEME a membrana
Water solenoid valve CEME membrane
Electrovanne eau CEME membrane
Electrovalvula agua CEME membrana

N.0382 3/8" 230V (8613) Ø 10mm
N.0383 3/8" 24V (8613) Ø 10mm

N.0384 1/2" 230V (8614) Ø 12mm
N.0385 1/2" 24V (8614) Ø 12mm

N.0386 3/4" 230V (8615) Ø 20mm
N.0387 3/4" 24V (8615) Ø 20mm



Elettrovalvola acqua CEME a membrana
Water solenoid valve CEME membrane
Electrovanne eau CEME membrane
Electrovalvula agua CEME membrana

N.0388 1" 230V (8616) Ø 25mm
N.0389 1" 24V (8616) Ø 25mm

N.0390 1"1/4 230V (8617) Ø 32mm
N.0391 1"1/4 24V (8617) Ø 32mm

N.0392 1"1/2 230V (8618) Ø 39mm
N.0393 1"1/2 24V (8618) Ø 39mm

N.0394 2" 230V (8619) Ø 51mm
N.0395 2" 24V (8619) Ø 51mm

N.0396 2"1/2 230V (8620) Ø 65mm
N.0397 2"1/2 24V (8620) Ø 65mm

N.0398 3" 230V (8621) Ø 75mm
N.0399 3" 24V (8621) Ø 75mm



Elettrovalvola acqua CEME a membrana
Water solenoid valve CEME membrane
Electrovanne eau CEME membrane
Electrovalvula agua CEME membrana

N.0400 3/8" 230V (8513) Ø 12mm
N.0410 3/8" 24V (8513) Ø 12mm

N.0420 1/2" 230V (8514) Ø 12mm
N.0430 1/2" 24V (8514) Ø 12mm



Cod.**Descrizione**

Elettrovalvola vapore CEME
 Steam solenoid valve CEME
 Electrovanne vapeur CEME
 Electrovalvula vapor CEME

N.0440 3/8" 230V (9003) Ø 12mm
 N.0450 3/8" 24V (9003) Ø 12mm

N.0460 1/2" 230V (9004) Ø 12mm
 N.0470 1/2" 24V (9004) Ø 12mm



Elettrovalvola vapore CEME
 Steam solenoid valve CEME
 Electrovanne vapeur CEME
 Electrovalvula vapor CEME

N.0500 3/8" 230V (9013) PTFE Ø 8mm
 N.0510 3/8" 24V (9013) PTFE Ø 8mm

N.0520 1/2" 230V (9014) PTFE Ø 8mm
 N.0530 1/2" 24V (9014) PTFE Ø 8mm



Elettrovalvola vapore CEME
 Steam solenoid valve CEME
 Electrovanne vapeur CEME
 Electrovalvula vapor CEME

N.0540 3/4" 230V (9015) PTFE Ø 21mm
 N.0550 3/4" 24V (9015) PTFE Ø 21mm

N.0560 1" 230V (9016) PTFE Ø 21mm
 N.0570 1" 24V (9016) PTFE Ø 21mm

N.0575 1"1/4 230V (9017) PTFE Ø 38mm
 N.0580 1"1/4 24V (9017) PTFE Ø 38mm

N.0585 1"1/2 230V (9018) PTFE Ø 38mm
 N.0590 1"1/2 24V (9018) PTFE Ø 38mm

N.0595 2" 230V (9019) PTFE Ø 50mm
 N.0598 2" 24V (9019) PTFE Ø 50mm



Électrovannes et pièces détachées
 Electrovalvulas y recambios

Z PRIMA

Cod.

Descrizione

Bobina piccola CEME
Small coil CEME
Bobine petite CEME
Bobina pequeña CEME

N.0600
N.0605

B4 230V (A1F/R)
B4 24V (A52/R)

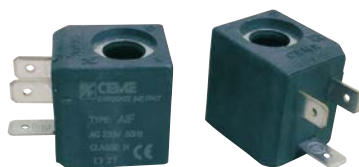

Bobina media CEME
Medium coil CEME
Bobine moyenne CEME
Bobina media CEME

N.0610
N.0620
N.0625

B6 230V (B1F/R)
B6 24V (BA2/R)
B6 24V DC (BC2/R)



Bobina CEME
Coil CEME
Bobine CEME
Bobina CEME

N.0630
N.0640
N.0642

B12 230V (C57/R)
B12 24V (C52/R)
B12 24V DC (CO2/R)

N.0644
N.0645

B12 230V 50-60HZ (C77/R)
B12 24V 50-60HZ (C72/R)

N.0650
N.0670

B12 110V (C55/R)
B12 230V 60HZ (C67/R)



Cod. Descrizione

Nucleo CEME
Core CEME
Noyau CEME
Nucleo CEME

N.0700 9922 (EPDM)
N.0710 9922 (PTFE)
N.0720 9934 (EPDM)



N.0700



N.0710



N.0720

Kit membrana per elettrovalvola CEME
Membrane set for solenoid valve CEME
Kit membrane pour electrovanne CEME
Kit membrana para electrovalvulas CEME

N.0950 8513 - 8514
N.0960 8513 - 8514 VITON



N.0950



N.0960

N.0965 8615 - 8715 NBR ESM 3/4"
N.0970 8616 - 8716 NBR ESM 1"



N.0965



N.0970



Cod.

Descrizione

Elettrovalvola vapore SA-MA media con regolazione
Steam solenoid valve SA-MA with regulation medium
Electrovanne vapeur SA-MA avec réglage moyenne
Electrovalvula vapor SA-MA con regulacion media



N.1000

1/4" 230V (180/R) Ø 2,8mm



N.1050

Elettrovalvola vapore SA-MA media
Steam solenoid valve SA-MA medium
Electrovanne vapeur SA-MA moyenne
Electrovalvula vapor SA-MA media



1/4" 230V (175) Ø 2,8mm



N.1070

Elettrovalvola vapore SA-MA media con regolazione
Steam solenoid valve SA-MA with regulation medium
Electrovanne vapeur SA-MA avec réglage moyenne
Electrovalvula vapor SA-MA con regulacion media



1/4" 230V (177/R) Ø 2,4mm



Cod. **Descrizione**

Elettrovalvola vapore SA-MA con regolazione
Steam solenoid valve SA-MA with regulation
Electrovanne vapeur SA-MA avec réglage
Electrovalvula vapor SA-MA con regulacion

N.1100 1/4" 230V (150/R) Ø 2,8mm
 N.1110 1/4" 24V (150/R) Ø 2,8mm

N.1115 1/4" 230V (150/R) Ø 3,5mm
 N.1120 1/4" 24V (150/R) Ø 3,5mm



Elettrovalvola vapore SA-MA con regolazione sul fondo
Steam solenoid valve SA-MA with regulation button
Electrovanne vapeur SA-MA avec réglage au fond
Electrovalvula vapor SA-MA con regulacion en fondo

N.1140 1/4" 230V (500/RS) Ø 4,5mm
 N.1150 1/4" 24V (500/RS) Ø 4,5mm

N.1160 3/8" 230V (500/RSP) Ø 5,5mm
 N.1170 3/8" 24V (500/RSP) Ø 5,5mm



Elettrovalvola vapore SA-MA
Steam solenoid valve SA-MA
Electrovanne vapeur SA-MA
Electrovalvula vapor SA-MA

N.1200 1/4" 230V (130/N) Ø 2,8mm
 N.1210 1/4" 24V (130/N) Ø 2,8mm

N.1220 1/4" 230V (130/SP) Ø 5,5mm
 N.1230 1/4" 24V (130/SP) Ø 5,5mm



Elettrovalvola vapore SA-MA
Steam solenoid valve SA-MA
Electrovanne vapeur SA-MA
Electrovalvula vapor SA-MA

N.1240 3/8" 230V (120) Ø 4,5mm
 N.1250 3/8" 24V (120) Ø 4,5mm

N.1260 3/8" 230V (120/SP) Ø 5,5mm
 N.1270 3/8" 24V (120/SP) Ø 5,5mm



Cod.

Descrizione

Elettrovalvola vapore SA-MA
Steam solenoid valve SA-MA
Electrovanne vapeur SA-MA
Electrovalvula vapor SA-MA

N.1280
N.1290

3/8" 230V (090) Ø 10mm
3/8" 24V (090) Ø 10mm



Elettrovalvola acqua SA-MA con filtro
Water solenoid valve SA-MA with filter
Electrovanne eau SA-MA avec filtre
Electrovalvula agua SA-MA con filtro

N.1300
N.1310

3/8" 230V (130/F) Ø 4mm
3/8" 24V (130/F) Ø 4mm



Elettrovalvola vapore SA-MA
Steam solenoid valve SA-MA
Electrovanne vapeur SA-MA
Electrovalvula vapor SA-MA

N.1320
N.1330

1/2" 230V (121) Ø 4,5mm
1/2" 24V (121) Ø 4,5mm



N.1340
N.1350

1/2" 230V (121/SP) Ø 5,5mm
1/2" 24V (121/SP) Ø 5,5mm

Bobina media per elettrovalvola SA-MA
Medium coil for solenoid valve SA-MA
Bobine moyenne pour electrovanne SA-MA
Bobina media para electrovalvula SA-MA

N.1500
N.1510

230V (175 - 177 - 180)
24V (175 - 177 - 180)



Cod. Descrizione

Bobina per elettrovalvola SA-MA
 Coil for solenoid valve SA-MA
 Bobine pour electrovanne SA-MA
 Bobina para electrovalvula SA-MA

N.1520 230V
 N.1530 24V



Nucleo per elettrovalvola SA-MA
 Core for solenoid valve SA-MA
 Noyau pour electrovanne SA-MA
 Nucleo para electrovalvula SA-MA

N.1600 MEDIA (175 - 177 - 180)
 N.1610 VITON
 N.1620 Ø 5,5mm (SP)



N.1600

N.1610

N.1620

Canotto Inox per elettrovalvola SA-MA
 Inox core guide for solenoid valve SA-MA
 Tube guide inox pour electrovanne SA-MA
 Guia inox para nucleo SA-MA

N.1700



Kit regolazione vapore per elettrovalvola SA-MA
 Steam regulation set for solenoid valve SA-MA
 Kit de réglage vapeur pour electrovanne SA-MA
 Kit de regulacion vapor para electrovalvula SA-MA

N.1800 1/4"
 N.1810 500/RS - 500/RSP



N.1800

N.1810

Cod.

Descrizione

Elettrovalvola acqua SIRAI
Water solenoid valve SIRAI
Electrovanne eau SIRAI
Electrovalvula agua SIRAI

N.2000 1/4" 230V (L121 B02) Ø 3,2mm
N.2010 1/4" 24V (L121 B02) Ø 3,2mm



Elettrovalvola acqua SIRAI
Water solenoid valve SIRAI
Electrovanne eau SIRAI
Electrovalvula agua SIRAI

N.2040 1/2" 230V (L182 B01) Ø 11,5mm
N.2050 1/2" 24V (L182 B01) Ø 11,5mm

N.2060 3/4" 230V (L182 B01) Ø 18mm
N.2070 3/4" 24V (L182 B01) Ø 18mm

N.2072 1" 230V (L182 B01) Ø 24mm
N.2074 1" 24V (L182 B01) Ø 24mm



Elettrovalvola acqua SIRAI
Water solenoid valve SIRAI
Electrovanne eau SIRAI
Electrovalvula agua SIRAI

N.2076 1"1/4 230V (L182 B48) Ø 30mm
N.2078 1"1/4 24V (L182 B48) Ø 30mm

N.2080 1"1/2 230V (L182 B48) Ø 45mm
N.2082 1"1/2 24V (L182 B48) Ø 45mm

N.2084 2" 230V (L182 B48) Ø 45mm
N.2086 2" 24V (L182 B48) Ø 45mm



Elettrovalvola scarico acqua SIRAI
Water outlet solenoid valve SIRAI
Electrovanne decharge eau SIRAI
Electrovalvula descarga agua SIRAI

N.2100 1"1/2 230V (D137 B08) Ø 36mm
N.2110 1"1/2 24V (D137 B08) Ø 36mm

N.2120 2" 230V (D137 B08) Ø 43mm
N.2130 2" 24V (D137 B08) Ø 43mm



Cod.	Descrizione
	Elettrovalvola vapore SIRAI Steam solenoid valve SIRAI Electrovanne vapeur SIRAI Electrovalvula vapor SIRAI
N.2220	1/4" 230V (L121 C01) Ø 3,2mm
N.2230	1/4" 24V (L121 C01) Ø 3,2mm



	Elettrovalvola vapore SIRAI Steam solenoid valve SIRAI Electrovanne vapeur SIRAI Electrovalvula vapor SIRAI
N.2240	3/8" 230V (L145 R2) Ø 10mm
N.2250	3/8" 24V (L145 R2) Ø 10mm
N.2260	1/2" 230V (L145 R2) Ø 10mm
N.2270	1/2" 24V (L145 R2) Ø 10mm
N.2280	3/4" 230V (L145 R4) Ø 16mm
N.2290	3/4" 24V (L145 R4) Ø 16mm



	Elettrovalvola vapore SIRAI Steam solenoid valve SIRAI Electrovanne vapeur SIRAI Electrovalvula vapor SIRAI
N.2300	1" 230V (L145 R4) Ø 18,5mm
N.2310	1" 24V (L145 R4) Ø 18,5mm



Cod. **Descrizione**

Bobina piccola per elettrovalvola SIRAI
Small coil for solenoid valve SIRAI
 Bobine petit pour electrovanne SIRAI
 Bobina pequeña para electroválvula SIRAI

N.2500 230V (Z614A)
 N.2510 24V (Z614A)



Bobina piccola per elettrovalvola SIRAI
Small coil for solenoid valve SIRAI
 Bobine petit pour electrovanne SIRAI
 Bobina pequeña para electroválvula SIRAI

N.2514 230V L182 (ZB10A)
 N.2515 24V L182 (ZB10A)



Bobina per elettrovalvola SIRAI
Coil for solenoid valve SIRAI
 Bobine pour electrovanne SIRAI
 Bobina para electroválvula SIRAI

N.2520 230V (Z530A)
 N.2530 24V (Z530A)



Bobina grande per elettrovalvola SIRAI
Big coil for solenoid valve SIRAI
 Bobine grande pour electrovanne SIRAI
 Bobina grande para electroválvula SIRAI

N.2540 230V (Z923G)
 N.2550 24V (Z923G)



Cod. Descrizione

Bobina per elettrovalvola SIRAI
 Coil for solenoid valve SIRAI
 Bobine pour electrovanne SIRAI
 Bobina para electrovalvula SIRAI

N.2560 230V L180 (ZA10A)
 N.2570 24V L180 (ZA10A)



Kit nucleo per elettrovalvola acqua SIRAI
 Core set for water solenoid valve SIRAI
 Kit noyau pour electrovanne eau SIRAI
 Kit nucleo para electrovalvula agua SIRAI

N.2600 L129 (G2877601)
 N.2605 L121 B02 (G3022804)



N.2600

N.2605

Nucleo per elettrovalvola SIRAI vapore
 Core for steam solenoid valve SIRAI
 Noyau pour electrovanne SIRAI vapeur
 Nucleo para electrovalvula SIRAI vapor

N.2630 3/8" - 1/2" L145 R2 (G2641702)
 N.2640 3/4" - 1" L145 R4 (G2665102)



N.2630

N.2640

Kit membrana per elettrovalvola vapore SIRAI
 Membrane set for steam solenoid valve SIRAI
 Kit membrane pour electrovanne vapeur SIRAI
 Kit membrana para electrovalvula vapor SIRAI

N.2700 3/8" - 1/2" (G2647501)
 N.2710 3/4" - 1" (G2653301)



N.2700

N.2710

Membrana per elettrovalvola acqua SIRAI
 Membrane for water solenoid valve SIRAI
 Membrane pour electrovanne eau SIRAI
 Membrana para electrovalvula agua SIRAI

N.2750 1/2" L182B - L180 B31 (2844302R)
 N.2760 3/4" L182B (2299701R)



N.2750

N.2760

Cod.	Descrizione		
N.3400	Elettrovalvola vapore OLAB con regolazione Steam solenoid valve OLAB with regulation Electrovanne vapeur OLAB avec réglage Electrovalvula vapor OLAB con regulacion		
N.3410	Bobina per elettrovalvola OLAB (7000) Coil for solenoid valve OLAB (7000) Bobine pour electrovanne OLAB (7000) Bobina para electrovalvula OLAB (7000)		
N.3920	Bobina per elettrovalvola PONY Coil for solenoid valve PONY Bobine pour electrovanne PONY Bobina para electrovalvula PONY		
N.3940	Kit adattamento bobina per elettrovalvola PONY vecchia Coil adapter set for old solenoid valve PONY Kit adaptation bobine pour electrovanne PONY vieux modele Kit de adaptacion bobina electrovalvula PONY tipo vejo	N.3920	N.3940
N.3960	Nucleo per elettrovalvola PONY Core for solenoid valve PONY Noyau pour electrovanne PONY Nucleo para electrovalvula PONY		
N.3980	Ghiera ottone + ptfе per elettrovalvola PONY Brass nut + ptfе for solenoid valve PONY Embout laiton + ptfе pour electrovanne PONY Anillo de laton + ptfе para electrovalvula PONY	N.3960	N.3980

Cod.**Descrizione**

Bobina per elettrovalvola RPE
 Coil for solenoid valve RPE
 Bobine pour electrovanne RPE
 Bobina para electrovalvula RPE

N.4500 230V
 N.4510 24V



Elettrovalvola acqua RPE
 Water solenoid valve RPE
 Electrovanne eau RPE
 Electrovalvula agua RPE

N.4300 3/8" M. - 3/8" M. 230V
 N.4310 3/8" M. - 3/8" M. 24V



Elettrovalvola acqua RPE
 Water solenoid valve RPE
 Electrovanne eau RPE
 Electrovalvula agua RPE

N.4320 3/8" F. - 3/8" F. 230V
 N.4330 3/8" F. - 3/8" F. 24V



Elettrovalvola acqua RPE
 Water solenoid valve RPE
 Electrovanne eau RPE
 Electrovalvula agua RPE

N.4340 1/2" M. - 1/2" M. 230V
 N.4350 1/2" M. - 1/2" M. 24V



Électrovannes et pièces détachées
 Electrovalvulas y recambios

Z PRIMA

Cod.

Descrizione

Elettrovalvola acqua ELBI 1 portagomma
Water solenoid valve ELBI 1 hose holder
Electrovanne eau ELBI 1 porte tube
Electrovalvula agua ELBI 1 portagoma

N.4360
N.4370

3/4"M. - Ø 12mm 230V
3/4"M. - Ø 12mm 24V

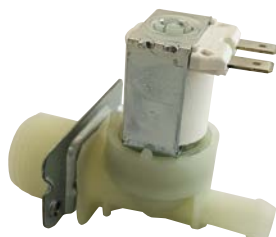

Elettrovalvola acqua ELBI 2 portagomma
Water solenoid valve ELBI 2 hose holders
Electrovanne eau ELBI 2 porte tube
Electrovalvula agua ELBI 2 portagoma

N.4380
N.4390

3/4"M. - Ø 12mm 230V
3/4"M. - Ø 12mm 24V



Elettrovalvola acqua ELBI 3 portagomma
Water solenoid valve ELBI 3 hose holders
Electrovanne eau ELBI 3 porte tube
Electrovalvula agua ELBI 3 portagoma

N.4400
N.4410

3/4"M. - Ø 12mm 230V
3/4"M. - Ø 12mm 24V



Elettrovalvola acqua RPE 4 portagomma
Water solenoid valve RPE 4 hose holders
Electrovanne eau RPE 4 porte tube
Electrovalvula agua RPE 4 portagoma

N.4420
N.4430

3/4"M. - Ø 12mm 230V
3/4"M. - Ø 12mm 24V



Cod.**Descrizione**

Elettrovalvola acqua ELBI 1 portagomma ad angolo
 Water solenoid valve ELBI 1 hose holder elbow
 Electrovanne eau ELBI 1 porte tube angle
 Electrovalvula agua ELBI 1 racord tubo angulo

N.4450
 N.4460

3/4"M. - Ø 12mm 230V
 3/4"M. - Ø 12mm 24V



Elettrovalvola acqua ELBI 2 portagomma angolo
 ELBI water solenoid valve 2 hose holder elbow
 Electrovanne eau ELBI 2 porte tube angle
 Electrovalvula agua ELBI 2 racord angulo

N.4470
 N.4475

3/4"M. - Ø 12mm 230V
 3/4"M. - Ø 12mm 24V



Elettrovalvola acqua ELBI 3 portagomma angolo
 ELBI water solenoid valve 3 hose holder elbow
 Electrovanne eau ELBI 3 porte tube angle
 Electrovalvula agua ELBI 3 racord angulo

N.4480
 N.4485

3/4"M. - Ø 12mm 230V
 3/4"M. - Ø 12mm 24V



Elettrovalvola acqua RPE 4 portagomma angolo
 RPE water solenoid valve 4 hose holder elbow
 Electrovanne eau RPE 4 porte tube angle
 Electrovalvula agua RPE 4 racord angulo

N.4490
 N.4495

3/4"M. - Ø 12mm 230V
 3/4"M. - Ø 12mm 24V



Cod. **Descrizione**

Bobina per elettrovalvola ELBI
Coil for solenoid valve ELBI
Bobine pour electrovanne ELBI
Bobina para electrovalvula ELBI

N.4200 230V
N.4210 24V



N.4800 Connettore piccolo per elettrovalvola
Small connector for solenoid valve
Connecteur petit pour electrovanne
Conector pequeño para electrovalvulas



N.4800

N.4810

N.4810 Connettore grande per elettrovalvola
Big connector for solenoid valve
Connecteur grand pour electrovanne
Conector grande para electrovalvulas

N.4900 Manopolina regolazione vapore per elettrovalvola
Steam regulation knob for solenoid valve
Bouton de réglage vapeur pour electrovanne
Manopla de regulacion vapor para electrovalvula



N.4900

N.6000 Elettrovalvola scarico acqua MDB
Water outlet solenoid valve MDB
N.6010 Electrovanne decharge eau MDB
Electrovalvula descarga agua MDB

N.6000 C-2 1"1/2 230V NC
N.6010 C-2 1"1/2 24V NC

N.6020 Elettrovalvola scarico acqua MDB
Water outlet solenoid valve MDB
N.6030 Electrovanne decharge eau MDB
Electrovalvula descarga agua MDB

N.6020 O-2 1"1/2 230V NO
N.6030 O-2 1"1/2 24V NO

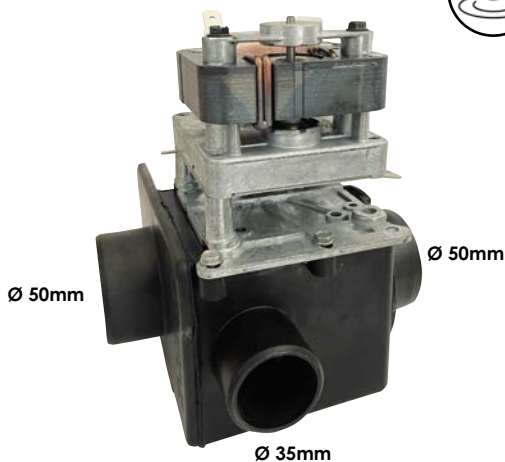

Cod. Descrizione

Elettrovalvola scarico acqua MDB
 Water outlet solenoid valve MDB
 Electrovanne decharge eau MDB
 Electrovalvula descarga agua MDB

N.6040 C-3 3" 230V NC
 N.6050 C-3 3" 24V NC

Elettrovalvola scarico acqua MDB
 Water outlet solenoid valve MDB
 Electrovanne decharge eau MDB
 Electrovalvula descarga agua MDB

N.6060 O-3 3" 230V NO
 N.6070 O-3 3" 24V NO

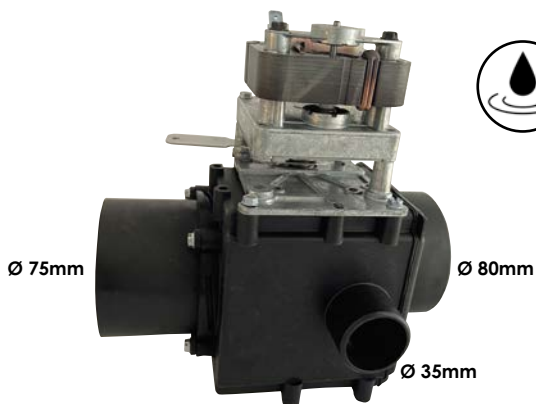

Elettrovalvola scarico acqua MDB
 Water outlet solenoid valve MDB
 Electrovanne decharge eau MDB
 Electrovalvula descarga agua MDB

N.6100 C-58 SO SC 230V NC

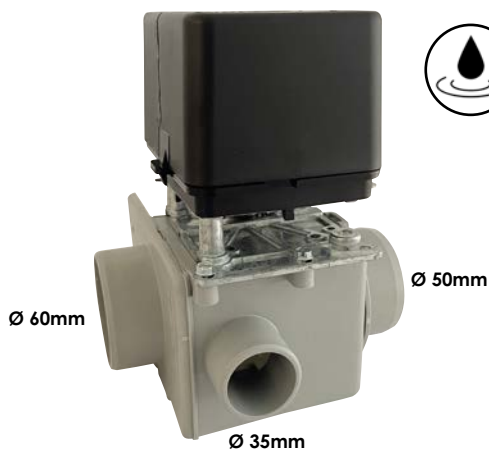

Elettrovalvola scarico acqua MDB
 Water outlet solenoid valve MDB
 Electrovanne decharge eau MDB
 Electrovalvula descarga agua MDB

N.6120 O-58 230V NO



Cod. **Descrizione**

Elettrovalvola scarico acqua MDP
 Water outlet solenoid valve MDP
 Electrovanne decharge eau MDP
 Electrovalvula descarga agua MDP

N.6140 MDP-O-2 SO 220/240V NO

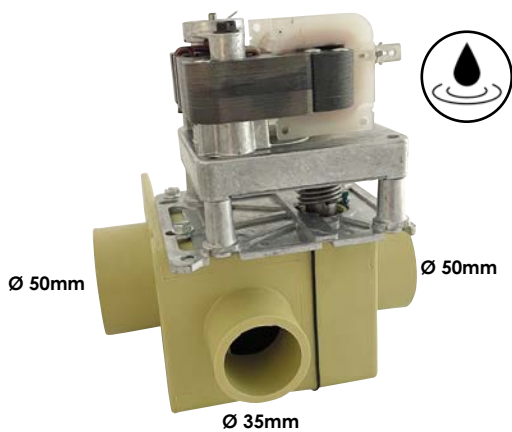

Elettrovalvola scarico acqua MDB
 Water outlet solenoid valve MDB
 Electrovanne decharge eau MDB
 Electrovalvula descarga agua MDB

N.6160 O-3 230V NO



Elettrovalvola scarico acqua MDB
 Water outlet solenoid valve MDB
 Electrovanne decharge eau MDB
 Electrovalvula descarga agua MDB

N.6180 LMDP-O-2 220/240V NO

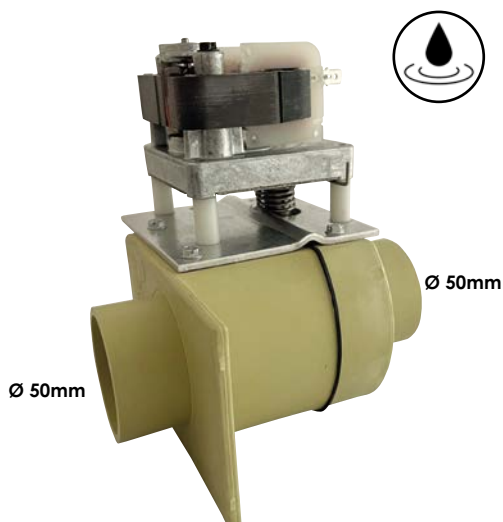

Cod. Descrizione

Elettrovalvola scarico acqua MDB angolo
Water outlet solenoid valve MDB angle
Electrovanne decharge eau MDB angle
Electrovalvula descarga agua MDB angulo

N.6300 C-3 3" RA 230V NC
 N.6310 C-3 3" RA 24V NC

Elettrovalvola scarico acqua MDB angolo
Water outlet solenoid valve MDB angle
Electrovanne decharge eau MDB angle
Electrovalvula descarga agua MDB angulo

N.6320 O-3 3" RA 230V NO
 N.6330 O-3 3" RA 24V NO

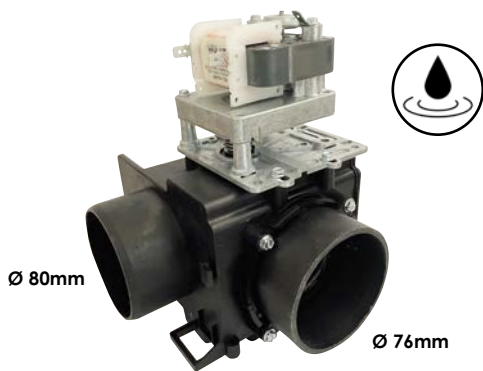

Elettrovalvola scarico acqua MDP angolo
Water outlet solenoid valve MDP angle
Electrovanne decharge eau MDP angle
Electrovalvula descarga agua MDP angulo

N.6400 MDP-O-2 RA 1"1/2 230V NO

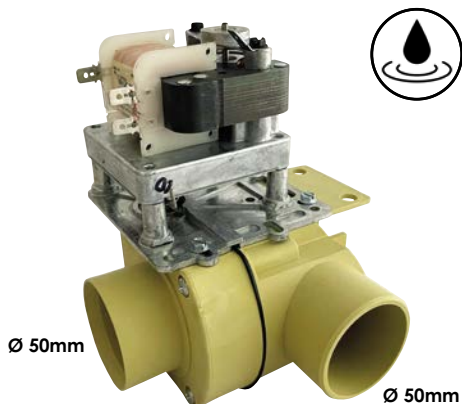

Elettrovalvola scarico acqua MDB angolo
Water outlet solenoid valve MDB angle
Electrovanne decharge eau MDB angle
Electrovalvula descarga agua MDB angulo

N.6450 O-3 3" RA SC 230V NO



Cod.	Descrizione	Image
O.0010	Generatore di vapore con ferro LEMM Steam generator with LEMM iron Chaudiere vapeur avec fer a repasser LEMM Generador de vapor con plancha LEMM	
O.0020	Generatore di vapore con ferro LEMM Steam generator with LEMM iron Chaudiere vapeur avec fer a repasser LEMM Generador de vapor con plancha LEMM	
O.0030	Generatore di vapore con ferro LEMM Steam generator with LEMM iron Chaudiere vapeur avec fer a repasser LEMM Generador de vapor con plancha LEMM	
O.0040	Generatore di vapore con ferro LEMM Steam generator with LEMM iron Chaudiere vapeur avec fer a repasser LEMM Generador de vapor con plancha LEMM	

Cod. Descrizione

Generatore di vapore con ferro LEMM
Steam generator with LEMM iron
Chaudière vapeur avec fer à repasser LEMM
Generador de vapor con plancha LEMM

O.0050 LT. 4,75



Generatore di vapore "STIR"
Steam generator "STIR"
Chaudière vapeur "STIR"
Generador de vapor "STIR"

O.0070 1800 LT. 1,8
 O.0075 2300 LT. 2,3
 O.0080 5000 LT. 4



O.0070



O.0080

Carrello portacaldaietta
Mobile holding generator stand
Chariot porte-chaudière vapeur
Carrito porta generador de vapor

O.0100



Tavolo aspirante riscaldato con pianale
Heated vacuum ironing table with iron rest
Table à repasser aspirante chauffante avec plancher
Mesa aspirante y calentada con plataforma

O.0200



O.0200

Tavolo aspirante riscaldato a incastro
Heated vacuum ironing table with fit
Table à repasser aspirante chauffante a emboitement
Mesa aspirante y calentada a encaje

O.0210

O.0210

Cod.

Descrizione

O.0300
Pedale elettrico
Electric pedal
Pedale électrique
Pedal electrico

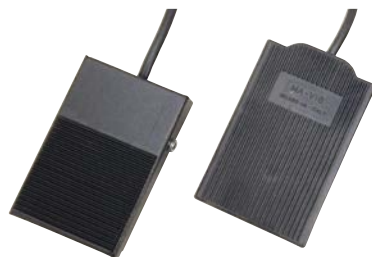

O.0300

O.0305

O.0305
Pedale elettrico plastica
Plastic electric pedal
Pedale électrique plastique
Pedal electrico plastico

O.0310
Pedale pneumatico
Pneumatic pedal
Pedale pneumatique
Pedal neumatico

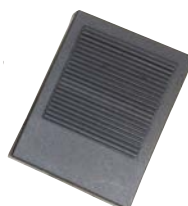

O.0310



O.0320

O.0320
Pedale pneumatico 3/C tondo
Round pneumatic pedal 3/C
Pedale pneumatique 3/C ronde
Pedal neumatico 3/C redondo

O.0400
Interruttore per caldaietta 4 faston
Switch for steam generator 4 faston
Interrupteur a temoin pour chaudiere 4 cosses
Interruptor 4 polos para generador de vapor



O.0400

O.0410

O.0420

O.0410



O.0420



O.0450
Interruttore per caldaietta 6 faston
Switch for steam generator 6 faston
Interrupteur a temoin pour chaudiere 6 cosses
Interruptor 6 polos para generador de vapor



O.0480

O.0480
Interruttore per caldaietta due pulsanti
Switch for steam generator 2 buttons
Interrupteur 2 boutons pour chaudiere
Interruptor 2 pulsadores para generador de vapor



Cod.

Descrizione

Spia luminosa 230V
Warning light 230V
Lumière d'alarme 230V
Señal luminoso 230V

O.0500



O.0510



O.0520



O.0500



O.0510



O.0520

Tappo di sicurezza
Safety cap
Bouchon de securite
Tapon de seguridad

O.0700

1/2" F.

Ø

19

O.0710

3/4" F.

24,5

O.0720

STIROVAP

18,4

O.0730

SARTITALIA NEW MODEL 3/4" F.

24,5

O.0740

3/8" M.

16,5

O.0750

1/2" M.

20,7

O.0760

1/2" F. UNSCREWING

19

O.0765

3/4" F. UNSCREWING

24,5

O.0770

STIROLUX 5/8" F.

20,8



O.0700



O.0710

O.0730



O.0720



O.0740



O.0750



O.0760



O.0765



O.0770

Guarnizione silicone per tappo
Safety cap silicon gasket
Joint silicone pour bouchon de securite
Guarnicion de silicona para tapon

O.0800

1/2" F.

O.0820

3/4" F.

O.0850

SARTITALIA OLD MODEL

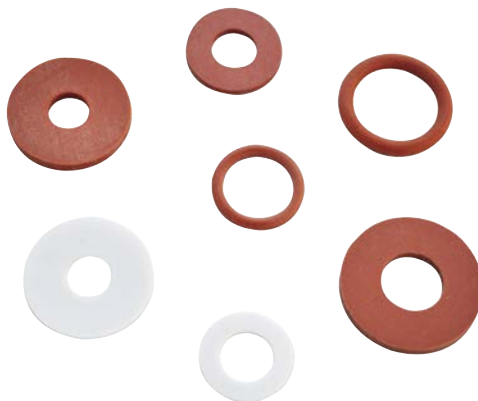

Guarnizione PTFE per tappo
Safety cap PTFE gasket
Joint PTFE pour bouchon de securite
Guarnicion de PTFE para tapon

O.0810

1/2" F.

O.0830

3/4" F.

O.0840

STIROVAP

O-ring silicone per tappo
Safety cap silicon o-ring
O-ring silicone pour bouchon de securite
O-ring de silicona para tapon

O.0860

3/8" M.

O.0870

1/2" M.

PRIMA

Chaudières, tables à repasser et pièces détachées
Generadores de vapor, mesas de planchar y recambios

Cod.

Descrizione

Pressostato MATER
MATER pressure switch
Pressostat MATER
Presostato MATER

O.1000 1/8" M. (1,5 - 4 bar)
O.1010 1/8" M. (2 - 6 bar)

O.1100 1/4" M. (1,5 - 4 bar)
O.1110 1/4" M. (2 - 6 bar)



Pressostato MATER manuale 2 microinterruttori
MATER pressure switch manual 2 microswitches
Pressostat MATER manuel 2 microcontacts
Presostato MATER manuel 2 microinterruptors

O.1150 1/4" M. (1,5 - 4 bar)
O.1160 1/4" M. (2 - 6 bar)



Pressostato MATER con calotta
MATER pressure switch with cover
Pressostat MATER avec capot
Presostato MATER con tapa

O.1200 1/4" F. (2 - 6 bar)



Pressostato MATER inox
MATER pressure switch inox
Pressostat MATER inox
Presostato MATER inox

O.1250 1/4" M. (4 - 9 bar) XP111



Pressostato MATER cilindrico
MATER cylindric pressure switch
Pressostat MATER cylindrique
Presostato MATER cilindrico

O.1280 1/4" M. (1,5 - 4 bar) XP600
O.1290 1/4" M. (2 - 6 bar) XP600



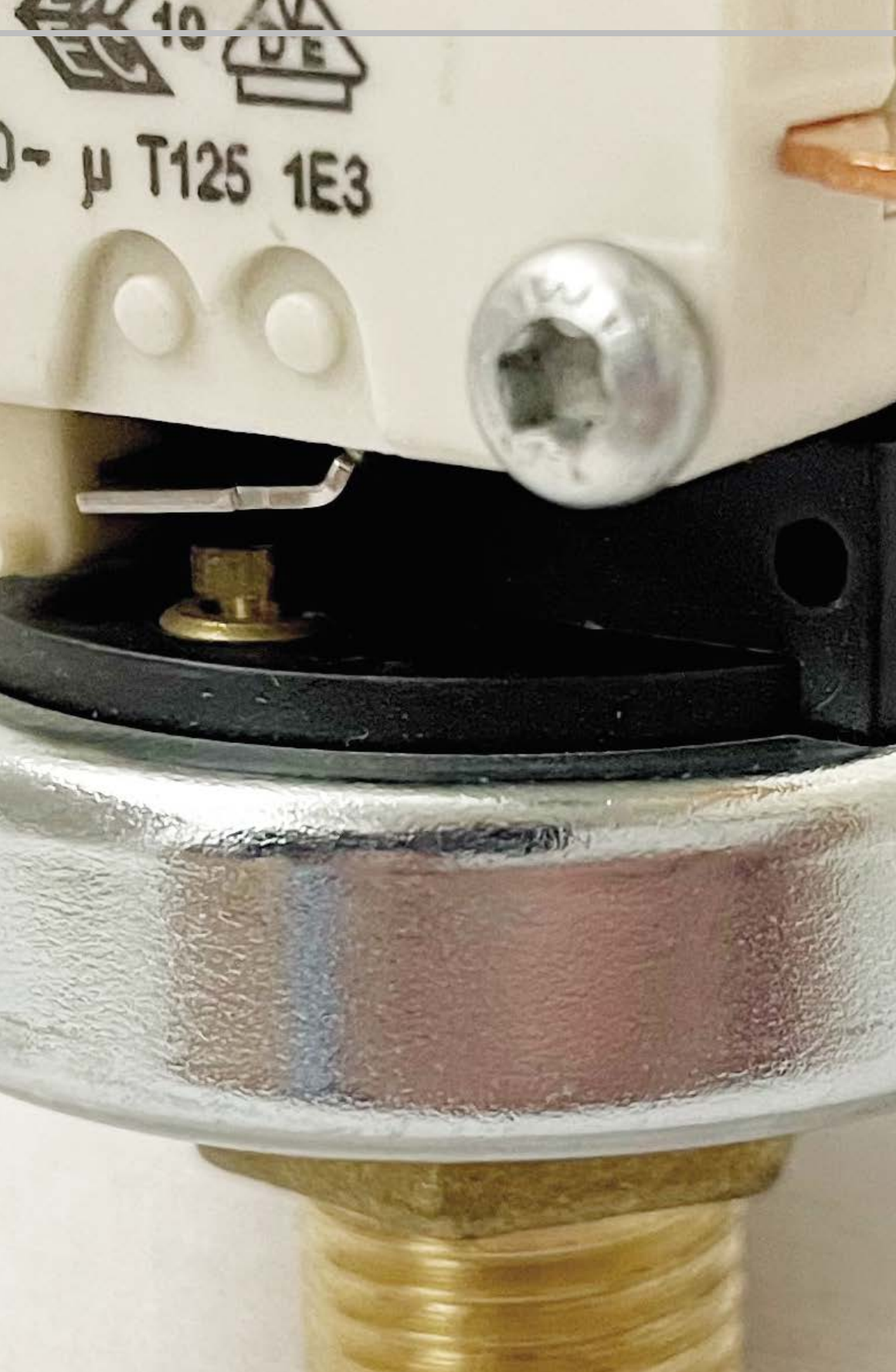

Chaudières, tables à repasser et pièces détachées
Generadores de vapor, mesas de planchar y recambios

PRIMA

Cod.

Descrizione

Pressostato FANTINI automatico
FANTINI automatic pressure switch
Pressostat FANTINI automatique
Presostato FANTINI automatico

O.1700
O.1710

B01 B 1/4" F. (1 - 5 bar)
B01 D 1/4" F. (2 - 15 bar)



O.1700

O.1710

Pressostato FANTINI manuale
FANTINI manual pressure switch
Pressostat FANTINI manuel
Presostato FANTINI manual

O.1720
O.1723
O.1726
O.1729

B01 AM 1/4" F. (0,7 - 3 bar)
B01 BM 1/4" F. (2 - 5,5 bar)
B01 CM 1/4" F. (3 - 7 bar)
B01 DM 1/4" F. (4 - 15 bar)



Pressostato DANFOSS automatico
DANFOSS automatic pressure switch
Pressostat DANFOSS automatique
Presostato DANFOSS automatico

O.1740

KP1 1/4" M. SAE (0,2 - 7,5 bar) **FREON**



Pressostato DANFOSS automatico
DANFOSS automatic pressure switch
Pressostat DANFOSS automatique
Presostato DANFOSS automatico

O.1750

KP5 1/4" M. SAE (8 - 32 bar) **FREON**



Cod. Descrizione

O.1760 Pressostato DANFOSS automatico
DANFOSS automatic pressure switch
Pressostat automatique DANFOSS
Presostato automatico DANFOSS
 KP35 1/4" M. (0,2 - 7,5 bar)



O.1770 Pressostato DANFOSS manuale
DANFOSS manual pressure switch
Pressostat manuel DANFOSS
Presostato manual DANFOSS
 KP35 1/4" M. (0,2 - 7,5 bar)



O.1810 Pressostato automatico
Automatic pressure switch
Pressostat automatique
Presostato automatico
 1/4" M. (0,7 - 6 bar)



O.1900 Contattore LOVATO
LOVATO bower contactor
Contacteur LOVATO
Contacteur LOVATO
 BF1210 A 230



O.1900

O.1910 BF2600 A 230



O.1910



Motoriduttori: tensioni e rotazione a richiesta
Synchronous motors: tensions and sense rotation on request
Moteurs synchrones : tensions et sense rotation sur demande
Motores síncronos: tensiones y sentido de rotación bajo pedido



Programmatori: tensioni e camme a richiesta
Programmiers: tensions and cams on request
Programmeurs: tensions et cam sur demande
Programadores: tensiones y camaras bajo pedido





Temporizzatori e timer su richiesta
Timers on request
Temporisateurs et timers sur demande
Temporizadores y timers bajo pedido



Cod.

Descrizione

- O.2145 TL10/B L=500mm 1/4" COVERED PTFE
- O.2150 TL10/B L=200mm 1/4"
- O.2152 TL10/B L=300mm 1/4"
- O.2154 TL10/B L=500mm 1/4"
- O.2156 TL30 L=500mm 3/8"

Sonda regolatore
Level probe
Sonde de niveau
Sonda de nivel

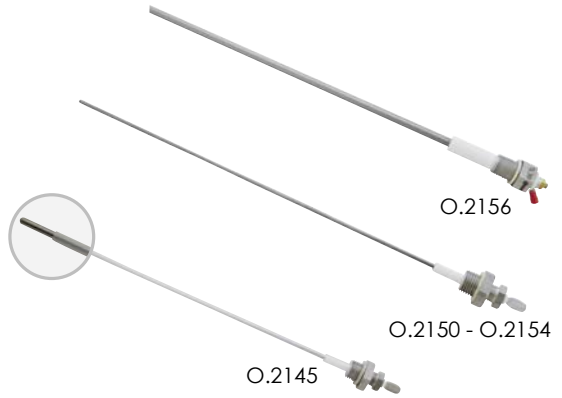

- O.2160 RL30/1ES/F R30 100K 230V
9.1.24.07G

Regolatore di livello elettronico
Electronic control level
Regulateur de niveau electronique
Regulador de nivel electronico



- O.2170 NRLH E 3009 03 R3 1SC 1/2HP 10K 230V
9.1.51.00G 04

Regolatore di livello elettronico
Electronic control level
Regulateur de niveau electronique
Regulador de nivel electronico



- O.2180 RL40/3ES/11 100K 230V
9.1.15.20G

Regolatore di livello elettronico
Electronic control level
Regulateur de niveau electronique
Regulador de nivel electronico



Cod.

Descrizione

Regolatore di livello elettronico
Electronic control level
Regulateur de niveau electronique
Regulador de nivel electronico

O.2190

RL30/1ES/F R120 100K 230V
9.1.24.10G 00



• • • • • • • • • •

Regolatore di livello elettronico
Electronic control level
Regulateur de niveau electronique
Regulador de nivel electronico

O.2200

RL40/1ES/11 100K Z R30 230V
9.1.15.00G



• • • • • • • • • •

Regolatore di livello elettronico
Electronic control level
Regulateur de niveau electronique
Regulador de nivel electronico

O.2210

RL30/3ES/F-G 250K 230V
9.1.19.86G 00



• • • • • • • • • •

Regolatore di livello elettronico
Electronic control level
Regulateur de niveau electronique
Regulador de nivel electronico

O.2215

RL1ES/C TIME-OUT 30" 250K 230V
9.1.15.15G 00



PRIMA

Chaudières, tables à repasser et pièces détachées
Generadores de vapor, mesas de planchar y recambios

Cod.

Descrizione

O.2220

Regolatore di livello
Control level
Regulateur de niveau
Regulador de nivel

CEL



O.2230

Regolatore di livello
Control level
Regulateur de niveau
Regulador de nivel

CEME



O.2240

Regolatore di livello
Control level
Regulateur de niveau
Regulador de nivel

SIRAI



O.2245

Regolatore di livello
Control level
Regulateur de niveau
Regulador de nivel

BARBANTI



Cod.

Descrizione

Regolatore di livello
Control level
Regulateur de niveau
Regulador de nivel

O.2260

PONY NEW MODEL

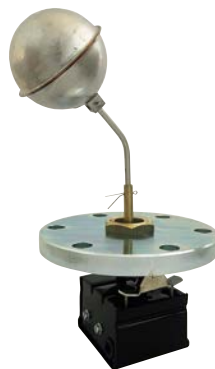

• • • • • • • • • •

Regolatore di livello meccanico
Mechanical control level
Regulateur de niveau mecanique
Regulador de nivel mecanico

O.2280



• • • • • • • • • •

Boccia galleggiante per regolatore di livello
Float ball for control level
Flotteur de regulateur de niveau
Boya para regulador de nivel

O.2300



O.2300



O.2310

Boccia galleggiante regolatore di livello
meccanico
Float ball for control level mechanical
Flotteur de regulateur de niveau mecanique
Boya para regulador de nivel mecanico

O.2310

Cod.

Descrizione

O.2320

Asta regolatore di livello
Rod for control level
Tige pour controle de niveau
Barra para regulador de nivel



O.2350

Flangia regolatore di livello
Flange control level
Bride regulateur de niveau
Brida para regulador de nivel



O.2350

O.2360

CAMPTEL 4 holes Ø 110mm
GHIDINI 6 holes Ø 135mm



O.2360

O.2400

Microinterruttore per regolatore di livello
Microswitch for control level
Microinterrupteur pour regulateur de niveau
Microinterruptor para regulador de nivel



O.2400

O.2410

SIRAI



O.2410

O.2430

BARBANTI



O.2430

O.2600

Indicatore di livello visivo
Sight level control
Indicateur de niveau a vue
Indicador de nivel visivo



O.2610

1/2" (2PCS)



Cod. Descrizione

Indicatore di livello visivo KLINGER
Sight level control KLINGER
Indicateur de niveau a vue KLINGER
Indicador de nivel visivo KLINGER

O.2650 mod. IV
 O.2660 mod. V



• • • • • • • • • •

Cristallo KLINGER tipo A
KLINGER Glass type A
Cristaux KLINGER type A
Cristal KLINGER tipo A

O.2670 mod. III L=165mm
 O.2672 mod. IV L=190mm
 O.2674 mod. V L=220mm
 O.2676 mod. VI L=250mm
 O.2678 mod. VII L=280mm



• • • • • • • • • •

Guarnizione cristallo KLINGER
Gasket KLINGER
Joint KLINGER
Junta KLINGER

O.2680 mod. III L=165mm
 O.2682 mod. IV L=190mm
 O.2684 mod. V L=220mm
 O.2686 mod. VI L=250mm
 O.2688 mod. VII L=280mm

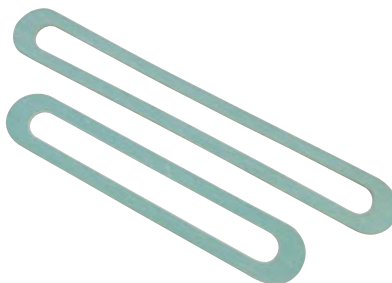

• • • • • • • • • •

Vetro livello
Glass level
Tube niveau
Tubo de vidrio para nivel

O.2700 Ø 12mm L=210mm



Guarnizione silicone per vetro livello
Silicon gasket for glass level
Joint silicone de tube niveau
Guarnicion de silicona para tubo en vidrio

O.2800



Cod.

Descrizione

	Pompa percloroetilene Perchloroethylene pump Electropompe perchlorethylene Electrobomba percloroetileno		
O.2870	AUES 150 Hp. 1,5	50Hz	1"1/4 - 1"1/4
O.2872	AUES 200 Hp. 2	50Hz	1"1/2 - 1"1/2
O.2874	AUES 300 Hp. 3	50Hz	2" - 2"



	Pompa percloroetilene Perchloroethylene pump Electropompe perchlorethylene Electrobomba percloroetileno		
O.2876	FBN 75 Hp. 0,75	50Hz	1" - 1"1/4
O.2878	FBN 100 Hp. 1	50Hz	1" - 1"1/4
O.2880	FBN 150 Hp. 1,5	50Hz	1" - 1"1/4



	Tenuta meccanica Mechanical seal Etancheite mecanique Retencion mecanica		
O.2890	Ø 19mm	AUES 150/200/300	
O.2892	Ø 17mm	FBN 75/100/150	



O.2890



O.2892

Cod.

Descrizione

Elettropompa CEME
CEME electropump
Electropompe CEME
Electrobomba CEME
O.2905 E505 230V 50Hz 47W



Elettropompa CEME
CEME electropump
Electropompe CEME
Electrobomba CEME
O.2910 ET 3009 230V 50Hz 60W



Elettropompa ULKA
ULKA electropump
Electropompe ULKA
Electrobomba ULKA
O.2940 EX5 230V 50Hz 48W



Elettropompa ULKA
ULKA electropump
Electropompe ULKA
Electrobomba ULKA
O.2950 EX7 230V 50Hz 48W



O.2970



O.2972



O.2974

Cod.

Descrizione

Elettropompa PEDROLLO
PEDROLLO electropump
Electropompe PEDROLLO
Electrobomba PEDROLLO

			Kw.	Hp.	R
O.3000	PKm 60	230V	0,37	0,50	1" - 1"
O.3005	PKm 65	230V	0,55	0,75	1" - 1"
O.3015	PKm 80	230V	0,75	1	1" - 1"
O.3020	PKm 90	230V	0,75	1	3/4" - 3/4"
O.3025	PKm 100	230V	1,1	1,5	1" - 1"
O.3100	PK 60	400V	0,37	0,50	1" - 1"
O.3105	PK 65	400V	0,55	0,75	1" - 1"
O.3115	PK 80	400V	0,75	1	1" - 1"
O.3120	PK 90	400V	0,75	1	3/4" - 3/4"
O.3125	PK 100	400V	1,1	1,5	1" - 1"



Elettropompa PEDROLLO
PEDROLLO electropump
Electropompe PEDROLLO
Electrobomba PEDROLLO

			Kw.	Hp.	R
O.3030	PQm 60	230V	0,37	0,50	1" - 1"
O.3035	PQm 65	230V	0,55	0,75	1" - 1"
O.3045	PQm 80	230V	0,75	1	1" - 1"
O.3050	PQm 90	230V	0,75	1	3/4" - 3/4"
O.3055	PQm 100	230V	1,1	1,5	1" - 1"
O.3060	PQm 81	230V	0,45	0,60	1/2" - 1/2"
O.3130	PQ 60	400V	0,37	0,50	1" - 1"
O.3135	PQ 65	400V	0,55	0,75	1" - 1"
O.3145	PQ 80	400V	0,75	1	1" - 1"
O.3150	PQ 90	400V	0,75	1	3/4" - 3/4"
O.3155	PQ 100	400V	1,1	1,5	1" - 1"
O.3160	PQ 81	400V	0,45	0,60	1/2" - 1/2"



Elettropompa PEDROLLO
PEDROLLO electropump
Electropompe PEDROLLO
Electrobomba PEDROLLO

			Kw.	Hp.	R
O.3065	PQm 60 BS	230V	0,37	0,50	1" - 1"
O.3070	PQm 65 BS	230V	0,55	0,75	1" - 1"
O.3075	PQm 81 BS	230V	0,55	0,75	1/2" - 1/2"
O.3165	PQ 60 BS	400V	0,37	0,50	1" - 1"
O.3170	PQ 65 BS	400V	0,55	0,75	1" - 1"
O.3175	PQ 81 BS	400V	0,55	0,75	1/2" - 1/2"



Cod. Descrizione

Girante per elettropompe PEDROLLO
 PEDROLLO electropump impeller
 Couronne pour electropompe PEDROLLO
 Girante para electrobomba PEDROLLO

- O.3200 60
- O.3205 65
- O.3210 70
- O.3220 81 - 90
- O.3230 100



Condensatore
 Condenser
 Condensateur
 Condensador

- O.3300 10 microfarad
- O.3310 12,5 microfarad
- O.3320 16 microfarad
- O.3330 20 microfarad
- O.3340 25 microfarad



Tenuta meccanica per elettropompe PEDROLLO
 PEDROLLO mechanical seal for electropump
 Etancheite mecanique pour electropompe PEDROLLO
 Retencion mecanica para electrobomba PEDROLLO

- O.3400 60 - 65 - 70
- O.3410 81 - 90
- O.3420 100 - 200 - 300

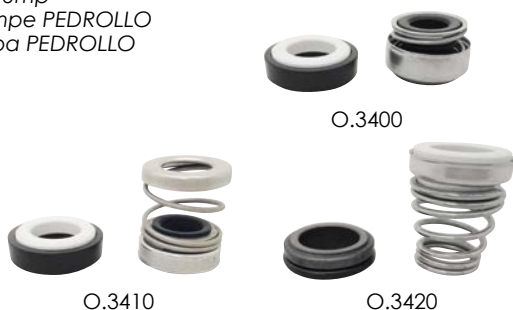

Cod.

Descrizione

O.3500
O.3510

Aspiratore completo per tavolo
Complete vacuum for table
Aspirateur complet pour table
Aspirador completo para mesa

230V Ø 180mm Hp. 0,50
230V Ø 200mm Hp. 0,50



O.3600
O.3610

Aspiratore completo per pressa
Complete vacuum for pressing machine
Aspirateur complet pour presse
Aspirador completo para prensa

230V Hp. 0,50
380V Hp. 0,50



O.3700
O.3710
O.3720
O.3730
O.3740
O.3750
O.3760

Ventola aspiratore
Fan for vacuum
Ailette aspirateur
Girante para aspirador

L=47mm Ø 200mm foro Ø 11mm
L=52mm Ø 160mm foro Ø 11mm
L=88mm Ø 200mm foro Ø 13mm
L=52mm Ø 180mm foro Ø 11mm
L=70mm Ø 160mm foro Ø 11mm
L=70mm Ø 133mm foro Ø 12mm
L=70mm Ø 180mm foro Ø 12mm



Cod. Descrizione

Motore aspiratore senza flangia
Exhaust fan motor without flange
Moteur aspirateur sans bride
Motor aspirador sin brida

O.3800 55W 230V Hp. 0,75 63M/2



Motore aspiratore plastica per tavoli casalinghi
Plastic exhaust fan motor for domestic ironing boards
Moteur aspirateur plastique pour tables menager
Motor aspirador plastico para mesas de hogar

O.3990 60W 230V Hp. 0,10



Motore aspiratore per tavoli semi-industriali
Exhaust fan motor for semi-industrial ironing boards
Moteur aspirateur pour tables semi-industriels
Motor aspirador para mesas semi-industrial

O.4000 100W 230V Hp. 0,10



Cod.

Descrizione

Valvola saracinesca "SEAL" (N.C. ritorno a molla)
Gate valve "SEAL" (N.C. spring return)
Robinet-vanne "SEAL" (N.F. retour à ressort)
Valvula de compuerta "SEAL" (N.C. retorno a muelle)

P.0100 3/4"
P.0110 1"
P.0120 1"1/4
P.0130 1"1/2
P.0140 2"
P.0150 2"1/2
P.0160 3"

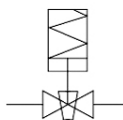

Valvola inclinata 45° "VILP" (N.C. ritorno a molla)
Inclined valve 45° "VILP" (N.C. spring return)
Vanne inclinee 45° "VILP" (N.F. retour à ressort)
Valvula inclinada 45° "VILP" (N.C. retorno a muelle)

P.0200 1/2"
P.0210 3/4"
P.0220 1"
P.0230 1"1/4
P.0240 1"1/2
P.0250 2"

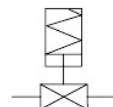

Valvola attuatore "VAT" (N.C. ritorno a molla)
Actuator valve "VAT" (N.C. spring return)
Vanne actionneur "VAT" (N.F. retour à ressort)
Valvula actuador "VAT" (N.C. retorno a muelle)

P.0300 1/2"
P.0310 3/4"
P.0320 1"
P.0330 1"1/4



Valvola saracinesca "DEAL" (N.C. ritorno ad aria)
Gate valve "DEAL" (N.C. air return)
Robinet-vanne "DEAL" (N.F. retour à air)
Valvula de compuerta "DEAL" (N.C. retorno a aire)

P.0500 3/4"
P.0510 1"
P.0520 1"1/4
P.0530 1"1/2
P.0540 2"
P.0550 2"1/2
P.0560 3"

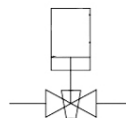

Cod. Descrizione

Valvola inclinata 45° "VAMOS" (N.C. ritorno a molla)
Inclined valve 45° "VAMOS" (N.C. spring return)
Vanne inclinées 45° "VAMOS" (N.F. retour à ressort)
Valvula inclinada 45° "VAMOS" (N.C. retorno a muelle)

P.0600 1/2"
 P.0610 3/4"
 P.0620 1"
 P.0630 1"1/4

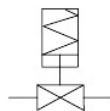

Valvola attuatore "VATAL" (N.C. ritorno a molla)
Actuator valve "VATAL" (N.C. spring return)
Vanne actionneur "VATAL" (N.F. retour à ressort)
Valvula actuador "VATAL" (N.C. retorno a muelle)

P.0800 3/4"
 P.0810 1"
 P.0820 1"1/4
 P.0830 1"1/2



Valvola saracinesca "NAAL" (N.A. ritorno a molla)
Gate valve "NAAL" (N.O. spring return)
Robinet-vanne "NAAL" (N.O. retour à ressort)
Valvula de compuerta "NAAL" (N.A. retorno a muelle)

P.0850 3/4"
 P.0860 1"
 P.0870 1"1/4

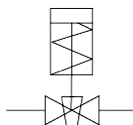

Teletermostato con sonda
Telethermostat with probe
Telethermostat avec sonde
Teletermostato con sonda

P.0900 Ø 63mm 1/2" 0-150°C
 P.0910 Ø 63mm 1/2" 0-350°C bulb Ø 8mm
 P.0950 Ø 63mm 1/2" 0-250°C bulb Ø 8mm



Cod. **Descrizione**

Teletermometro con sonda
Telethermometer with probe
Telethermometre avec sonde
Teletermometro con sonda

P.1000 3/8" 0-120°C
P.1010 1/2" 0-120°C



Teletermostato DIGIT
Telethermostat DIGIT
Telethermostat DIGIT
Teletermostato DIGIT

P.1100 IC 902 PTC 12-24V
P.1120 IC 912 PT100 12-24V



Teletermostato DIGIT EWPC
Telethermostat DIGIT EWPC
Telethermostat DIGIT EWPC
Teletermostato DIGIT EWPC

P.1130 800 PTC 230V
P.1140 800 PTC 24V
P.1150 800/T PT100 230V
P.1160 800/T PT100 24V



Sonda PTC
Probe PTC
Sonde PTC
Sonda PTC

P.1200 L=1500mm 140°C

Sonda PT100
Probe PT100
Sonde PT100
Sonda PT100

P.1210 L=3000mm 600°C



P.1200



P.1210

Cod.

Descrizione

Valvola DANFOSS con sonda Ø 9,5mm
DANFOSS valve with probe Ø 9,5mm
Vanne DANFOSS avec sonde Ø 9,5mm
Valvula DANFOSS con sonda Ø 9,5mm

P.1500

AVTA 15 1/2" 25° - 65°C



Portasonda
Probe holder
Portesonde
Soporte sonda

P.1510

1/2" Ø 9,5mm



Valvola DANFOSS con sonda Ø 18mm
DANFOSS valve with probe Ø 18mm
Vanne DANFOSS avec sonde Ø 18mm
Valvula DANFOSS con sonda Ø 18mm

P.1550

AVTA 15 1/2" 25° - 65°C

P.1560

AVTA 20 3/4" 25° - 65°C

P.1570

AVTA 25 1" 25° - 65°C



Portasonda
Probe holder
Portesonde
Soporte sonda

P.1580

3/4" Ø 18mm



Cod.	Descrizione
	Valvola DANFOSS DANFOSS valve Vanne DANFOSS Valvula DANFOSS
P.1600	WVFX 15 1/2" 4 - 23 bar
P.1610	WVFX 20 3/4" 4 - 23 bar



P.1620	Capillare raccordato Capillary with connection Capillaire avec raccords Capilar racordado
--------	--



P.1900	Compressore BER-MAR Compressor BER-MAR Compresseur BER-MAR Compresor BER-MAR
--------	---



P.2000	Pressostato aria NE-MA 4 vie per BER-MAR NE-MA air pressure switch 4 ways for BER-MAR Pressostat NE-MA air 4 voies pour BER-MAR Presostato NE-MA aire 4 vias para BER-MAR
--------	--



Cod. Descrizione

Kit riparazione compressore BER-MAR
Repairing kit for BER-MAR compressor
Jeu de reparation pour compresseur BER-MAR
Kit de reparacion para compresor BER-MAR

P.2100



Valvola di sicurezza compressore BER-MAR
Safety valve for BER-MAR compressor
Soupape de securite pour compresseur BER-MAR
Valvula de seguridad para compresor BER-MAR

P.2200

1/4"



Valvola di ritegno compressore BER-MAR
Non return valve for BER-MAR compressor
Soupape de retenue pour compresseur BER-MAR
Valvula de retencion para compresor BER-MAR

P.2250

1/2" - 3/8"



Rubinetto spurgo compressore
Compressor bleed valve
Vanne de purge de compresseur
Valvula de purga de compresor

P.2260

1/4"



Cod. **Descrizione**

Imbuto distillo nylon
Nylon funnel distiller
Entonnoir nylon pour distillateur
Embudo nylon para destilador

P.2400 1/2"



Imbuto dosaggio saponi
Soaps dispenser funnel
Entonnoir pour distributeur savon
Embudo dispensador de jabon

P.2510 3/4"
P.2520 1"



Imbuto per carbone
Coal funnel
Entonnoir pour charbon
Embudo de carbon

P.2600 3/4"
P.2610 1"



Sacchetto con carbone
Bag with coal
Sac avec charbon
Bolsa con carbon

P.2650 STANDARD Kg. 0,800
P.2660 MAXI Kg. 1,500



Cod. Descrizione

Carboni attivi minerali per aria rigenerabili
Activated mineral carbons for air regenerable
Charbons actifs minéraux pour air regenerable
Minerales de carbon activado para air regenerable

P.2800



Carboni attivi minerali per aria
Activated mineral carbons for air
Charbons actifs minéraux pour air
Minerales de carbon activado para air

P.2810



Carboni attivi minerali per solvente
Activated mineral carbons for solvent
Charbons actifs minéraux pour solvent
Minerales de carbon activado para disolvente

P.2850



Carboni attivi vegetali per acqua
Activated vegetal carbons for water
Charbons actifs vegetal pour eau
Carbon vegetal activado para agua

P.2870



Cod.	Descrizione		
P.3000	Faro distillatore <i>Headlight for distiller</i> <i>Feu pour distillateur</i> <i>Faro destilador</i>		
P.3050	Vetro faro distillatore <i>Glass for headlight distiller</i> <i>Verre pour feu distillateur</i> <i>Cristal para faro destilador</i>		
P.3060	Guarnizione faro distillatore <i>Gasket for headlight distiller</i> <i>Joint pour feu distillateur</i> <i>Guarnicion para faro destilador</i>		
P.3100	Valvola di sicurezza distillatore <i>Safety pressure valve for distiller</i> <i>Soupape de securite pour distillateur</i> <i>Valvula de seguridad para destilador</i>		
P.3150	Valvola aspirazione distillatore <i>Suction safety valve for distiller</i> <i>Soupape de aspiration pour distillateur</i> <i>Valvula aspiracion para destilador</i>		

Cod. Descrizione

Centralina controllo asciugatura
 Drying control unit
 Contrôle électronique séchage
 Caja eléctrica secamento

P.3200



Sonda "HSW" per centralina controllo asciugatura
 Probe "HSW" for drying control unit
 Sonde "HSW" pour contrôle électronique séchage
 Sonda "HSW" para caja eléctrica secamento

P.3205



P.3205

Sonda per centralina controllo asciugatura
 Probe for drying control unit
 Sonde pour contrôle électronique séchage
 Sonda para caja eléctrica secamento

P.3210



P.3210



Portalamпада faro distillatore
 Lampholder for headlight distiller
 Douille pour feu distillateur
 Portalamparas para faro destilador

P.3290



P.3290

Lampadina faro distillatore
 Bulb for distiller
 Ampoule pour feu de distillateur
 Bombilla para faro destilador

P.3300

1C 25W 24V E14 (new model)

P.3310







2C 20W 24V (old model)



P.3300



P.3310

Cod.	Descrizione	
P.3990 P.4000 P.4010	Spia passaggio solvente senza lampadina <i>Solvent passage sight glass without bulb</i> <i>Vojant de passage solvant sans ampoule</i> <i>Vidrio passaje solvente sin bombilla</i>	
P.4100	Lampadina spia passaggio solvente <i>Bulb solvent passage sight glass</i> <i>Ampoule vojant de passage solvant</i> <i>Bombilla vidrio passaje solvente</i>	
P.4110	Cappuccio gomma spia passaggio solvente <i>Rubber cap for sight passage solvent lamp</i> <i>Couvercle en caoutchouc pour vojant de passage pour lampe solvant</i> <i>Tapon de goma de vidrio passaje de la lampara de disolvente</i>	
P.4115	Sgocciolatoio spia passaggio solvente <i>Drip four solvent passage sight glass</i> <i>Goutte pour vojant de passage solvant</i> <i>Goteo para vidrio passaje solvente</i>	
P.4200 P.4210 P.4220	Spia passaggio solvente doppio vetro senza lampadina <i>Solvent passage sight double glass without bulb</i> <i>Vojant de passage solvant avec double vitrage sans ampoule</i> <i>Vidrio doble passaje solvente sin bombilla</i>	
P.4230	Lampadina spia passaggio solvente con adattatore <i>Bulb solvent passage sight glass with adapter</i> <i>Ampoule vojant de passage solvant avec adaptateur</i> <i>Bombilla vidrio passaje solvente con adaptador</i>	

Cod. Descrizione

Condensatore completo nylon
Complete condenser nylon
Condensateur complet nylon
Condensador completo nylon

P.5000 PM10
 P.5005 PM10 BIGGER
 P.5010 PM12



P.5005

Condensatore completo inox
Complete condenser inox
Condensateur complet inox
Condensador completo inox

P.4990 PM6
 P.4995 PM10
 P.5015 PM12
 P.5020 PM18
 P.5030 PM25
 P.5040 PM35



P.4990

Condensatore senza serpentina nylon
Condenser nylon without serpentine
Condensateur nylon sans serpentin
Condensador nylon sin serpentina

P.5110 PM10
 P.5120 PM10 BIGGER
 P.5130 PM12



P.5120

Pièces détachées pour machines de nettoyage à sec
 Recambios para máquinas de lavado a seco

PRIMA

P

Cod.

Descrizione

Condensatore senza serpentina inox
Condenser inox without serpentine
Condensateur inox sans serpentin
Condensador inox sin serpentina

P.5100
P.5105
P.5135
P.5140
P.5150
P.5160

PM6
PM10
PM12
PM18
PM25
PM35



P.5100

Serpentina
Serpentine
Serpentin
Serpentina

P.5200
P.5220

PM6
PM10 BIGGER



P.5200

P.5220

Serpentina
Serpentine
Serpentin
Serpentina

P.5210
P.5230
P.5240
P.5250
P.5260

PM10
PM12
PM18
PM25
PM35



Cod. Descrizione

Condensatore completo inox
 Complete condenser inox
 Condensateur complet inox
 Condensador completo inox

	R	X	Y	h mm	Ø mm
P.4490 PM6	1/2"	2"	1"	220	150
P.4495 PM10	1/2"	2"	1"	375	150
P.5015 PM12	1/2"	2"	1"	375	150
P.5020 PM18	3/4"	2"	1"	500	183
P.5030 PM25	3/4"	2"	1 1/4"	608	183
P.5040 PM35	3/4"	2"	1 1/4"	608	213

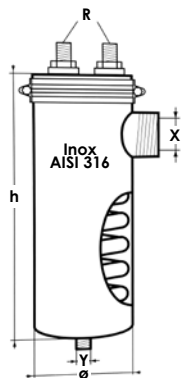

Condensatore completo nylon
 Complete condenser nylon
 Condensateur complet nylon
 Condensador completo nylon

	R	X	Y	h mm	Ø mm
P.5000 PM10	1/2"	2"	1"	390	150
P.5005 PM10 BIG	1/2"	2"	1"	315	180
P.5010 PM12	1/2"	2"	1"	390	150

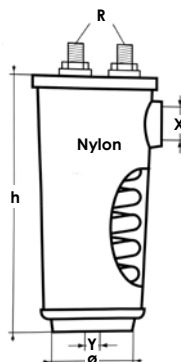

Serpentina
 Serpentine
 Serpentin
 Serpentina

	R	h mm	Ø mm
P.5200 PM6	1/2"	200	140
P.5210 PM10	1/2"	350	140
P.5220 PM10 BIG	1/2"	275	175
P.5230 PM12	1/2"	350	140
P.5240 PM18	3/4"	470	170
P.5250 PM25	3/4"	570	170
P.5260 PM35	3/4"	580	205

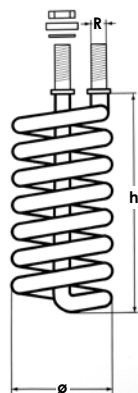

Pièces détachées pour machines de nettoyage à sec
 Recambios para máquinas de lavado a seco

PRIMA

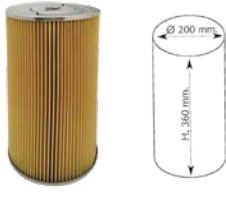

MINI



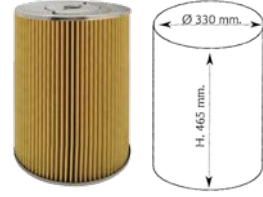

MEDIA



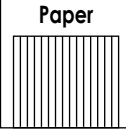
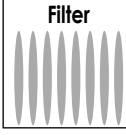

MAXI

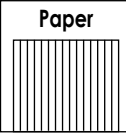
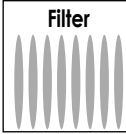

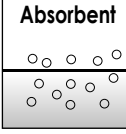
P.6000	MINI 1			Filtrante
P.6300	MEDIA F			Filter
P.6600	MAXI F			Filtrante Filtracion

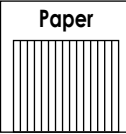
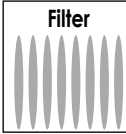
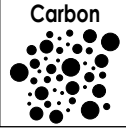
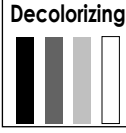
P.6020	MINI 2S			Filtrante - assorbente
P.6310	MEDIA S			Filter - absorbent
P.6610	MAXI S			Filtrante - assorbente Filtracion - absorbente

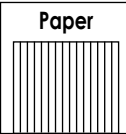
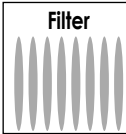
P.6030	MINI 3			Filtrante - decolorante
P.6320	MEDIA C			Filter - decolourant
P.6620	MAXI C			Filtrante - decolorante Filtracion - decolorante

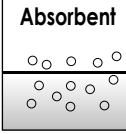
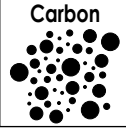
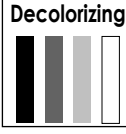
P.6010	MINI 2			Filtrante - assorbente - decolorante
P.6330	MEDIA			Filter - absorbent - decolourant
P.6630	MAXI			Filtrante - assorbente - decolorante Filtracion - absorbente - decolorante

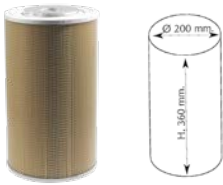

MINI



MEDIA

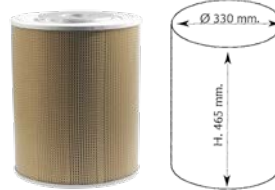

MAXI

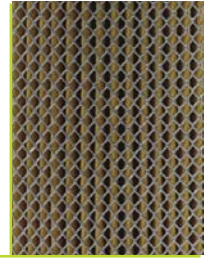

- P.6150 MINI 1R
- P.6450 MEDIA FR
- P.6750 MAXI FR

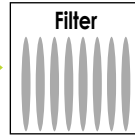
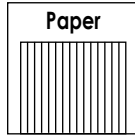

- Filtrante
- Filter
- Filtrante
- Filtracion

- P.6170 MINI 2SR
- P.6460 MEDIA SR
- P.6760 MAXI SR

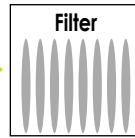
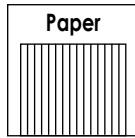

- Filtrante - absorbente
- Filter - absorbent

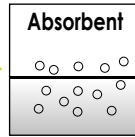
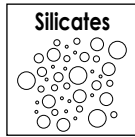

- Filtrante - absorbente
- Filtracion - absorbente

- P.6180 MINI 3R
- P.6470 MEDIA CR
- P.6770 MAXI CR

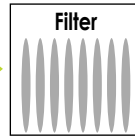
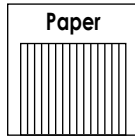

- Filtrante - decolorante
- Filter - decolourant

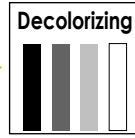
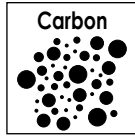

- Filtrante - decolorante
- Filtracion - decolorante

- P.6160 MINI 2R
- P.6480 MEDIA R
- P.6780 MAXI R

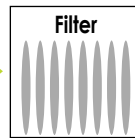
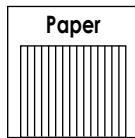

- Filtrante - absorbente - decolorante
- Filter - absorbent - decolourant

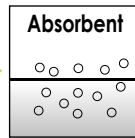
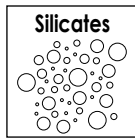

- Filtrante - absorbente - decolorante

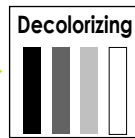
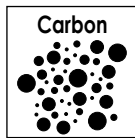

- Filtracion - absorbente - decolorante

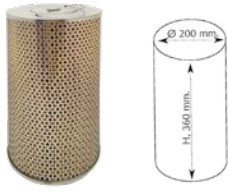

MINI



MEDIA

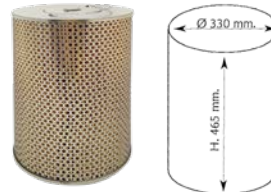

MAXI

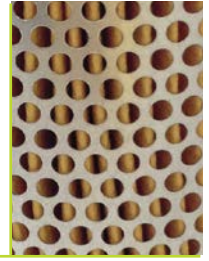

P.6100 MINI 1L

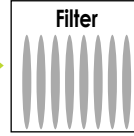
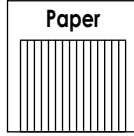

Filtrante

P.6400 MEDIA FL

Filter

P.6700 MAXI FL

Filtrante

Filtracion

P.6120 MINI 2SL

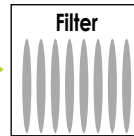
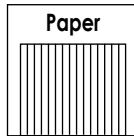

Filtrante - assorbente

P.6410 MEDIA SL

Filter - absorbent

P.6710 MAXI SL

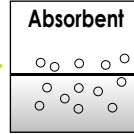
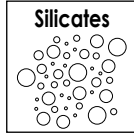

Filtrante - assorbente

Filtracion - absorbente

P.6130 MINI 3L

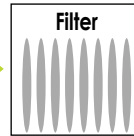
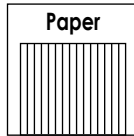

Filtrante - decolorante

P.6420 MEDIA CL

Filter - decolourant

P.6720 MAXI CL

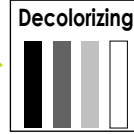
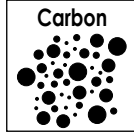

Filtrante - decolorante

Filtracion - decolorante

P.6110 MINI 2L

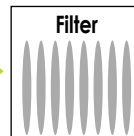
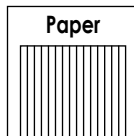

Filtrante - assorbente - decolorante

P.6430 MEDIA L

Filter - absorbent - decolourant

P.6730 MAXI L

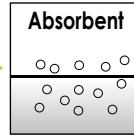
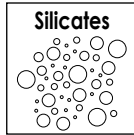

Filtrante - assorbente - decolorante

Filtracion - absorbente - decolorante

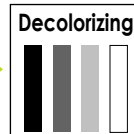
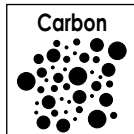



MINI



MEDIA

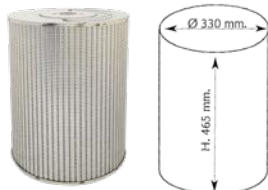

MAXI

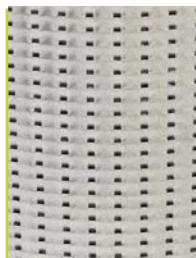

P.6220 MINI 4TS

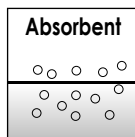
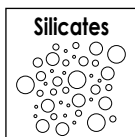

Assorbente

P.6520 MEDIA TS

Absorbent

Absorbante

P.6820 MAXI TS

Absorbente

P.6210 MINI 4TCV

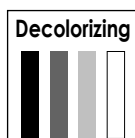
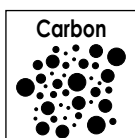

Decolorente

P.6510 MEDIA TCV

Decolourant

P.6810 MAXI TCV

Decolorante

Decolorante

P.6200 MINI 4

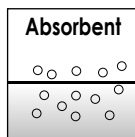
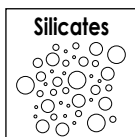

Assorbente - decolorente

P.6500 MEDIA TCS

Absorbent - decolourant

P.6800 MAXI TCS

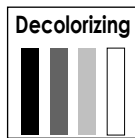
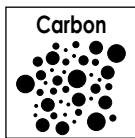

Absorbante - decolorante

Absorbente - decolorante

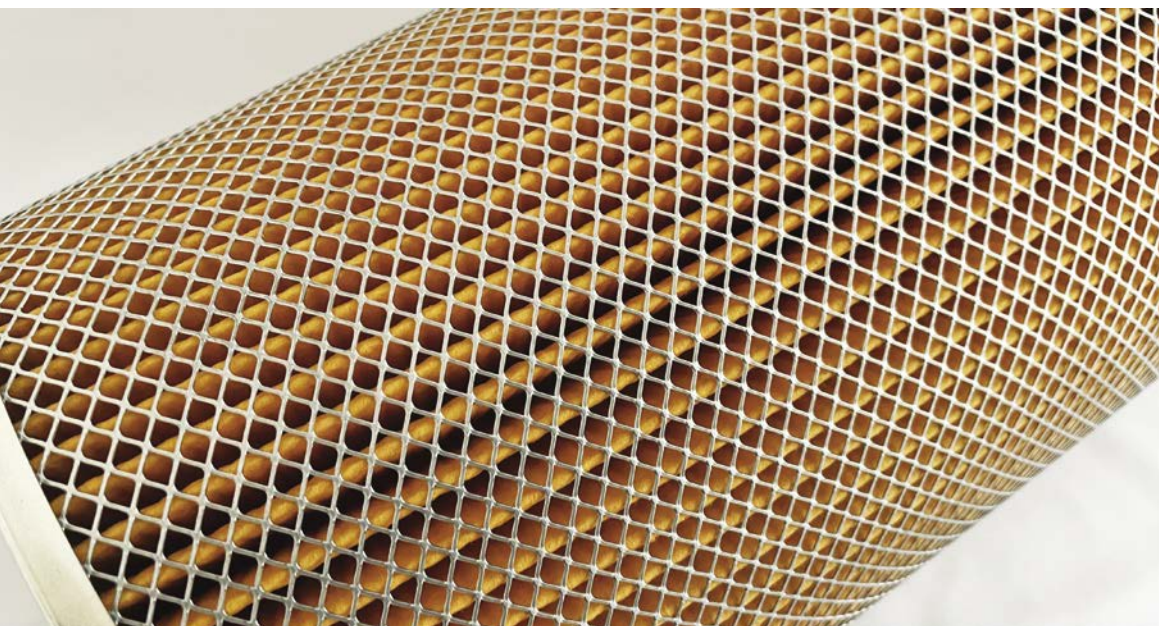

Cod.

Descrizione

Resistenza per tavolo
Heating element for table
Resistance pour table
Resistencia para mesa

	W.	L
Q.0010	300	1000mm
Q.0020	400	1000mm
Q.0030	500	1000mm
Q.0040	600	1000mm
Q.0050	800	1000mm

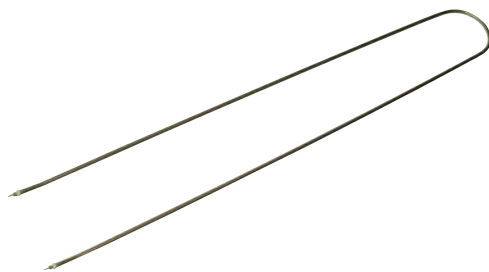

Resistenza per Jeannette
Heating element for sleeve arm
Resistance pour Jeannette
Resistencia para brazo manga

	W.	L
Q.0100	100	400mm
Q.0110	150	400mm
Q.0120	200	400mm



Legenda abbreviazioni
Abbreviations list
Liste d'abbreviations
Lista de abreviaciones

L=mm.	lunghezza length longueur largo
O	occhiello button hole boucles ojales
R	raccordo fitting raccord racor
GT Ø	Diametro porta sonda Probe holder diameter Diametre porte sonde Diametro soporte sonda

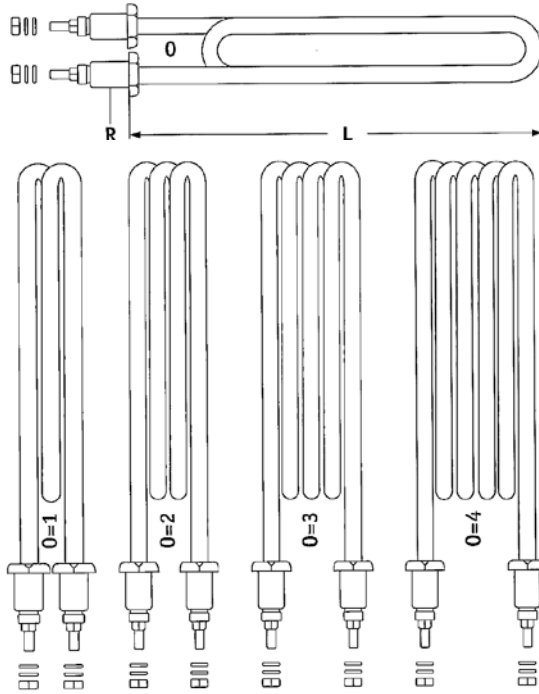

Cod.	Descrizione	R	W	L = mm	O
	Elemento corto PONY Short element PONY Resistance courte PONY Elemento corto PONY				
Q.0210		3/8	1650	180	2
Q.0220		3/8	2000	180	2
Q.0230		3/8	2500	180	2
Q.0240		3/8	3000	180	2
	Elemento PONY Element PONY Resistance PONY Elemento PONY				
Q.0300		3/8	2000	250	2
Q.0310		3/8	2500	250	2
Q.0320		3/8	3000	270	2
Q.0330		3/8	3300	270	2
Q.0340		3/8	3500	270	2



Cod.	Descrizione	R	W	L = mm	O
	Elemento PONY <i>Element PONY</i> <i>Resistance PONY</i> <i>Elemento PONY</i>				
Q.0350		3/8	4000	270	3
Q.0360		3/8	4500	270	3
Q.0370		3/8	5000	270	3
Q.0380		3/8	6000	270	3
Q.0390		3/8	7000	360	3
Q.0400		3/8	8000	360	3
Q.0410		3/8	9000	360	4
Q.0450		3/8	10000	360	4



Elemento BM - FIMAS
Element BM - FIMAS
Resistance BM - FIMAS
Elemento BM - FIMAS

Q.0500		3/8	1500	230	1
Q.0510		3/8	2000	230	2
Q.0520		3/8	2000	320	2
Q.0530		3/8	2500	230	2
Q.0540		3/8	2500	320	2
Q.0550		3/8	3000	230	3
Q.0560		3/8	3000	320	2
Q.0570		3/8	3500	230	3
Q.0580		3/8	3500	320	2
Q.0590		3/8	3700	320	2
Q.0600		3/8	4000	230	3
Q.0610		3/8	4000	320	3
Q.0620		3/8	4500	230	3
Q.0630		3/8	4500	320	3
Q.0640		3/8	5000	230	3
Q.0650		3/8	5000	320	3
Q.0660		3/8	5500	320	3
Q.0670		3/8	6000	230	3
Q.0680		3/8	6000	320	3
Q.0690		3/8	6500	320	3
Q.0700		3/8	7000	320	3



Elemento CAMPTEL - GHIDINI
Element CAMPTEL - GHIDINI
Resistance CAMPTEL - GHIDINI
Elemento CAMPTEL - GHIDINI

Q.0800		3/8	1300	270	1
Q.0810		3/8	1500	270	1
Q.0820		3/8	1700	270	1
Q.0830		3/8	2000	270	1
Q.0840		3/8	2300	270	1
Q.0850		3/8	2500	270	1
Q.0860		3/8	2700	270	1
Q.0870		3/8	3000	270	1



Cod.	Descrizione	R	W	L = mm	O
	Elemento con porta sonda CAMPTEL <i>Element with probe holder CAMPTEL</i> <i>Resistance avec porte sonde CAMPTEL</i> <i>Elemento con soporte sonda CAMPTEL</i>				
Q.0900		3/8	4000	270	3 GT Ø 7mm
Q.0910		3/8	5000	270	3 GT Ø 7mm
Q.0920		3/8	6000	270	3 GT Ø 7mm



	Elemento COMEL <i>Element COMEL</i> <i>Resistance COMEL</i> <i>Elemento COMEL</i>				
Q.1000		3/8	1650	180	1
Q.1010		3/8	2000	180	1



	Elemento COMEL (faston) <i>Element COMEL (faston)</i> <i>Resistance COMEL (faston)</i> <i>Elemento COMEL (faston)</i>				
Q.1020		3/8	1650	180	1
Q.1030		3/8	2000	180	1
Q.1040		3/8	2500	180	1



	Elemento con portasonda COMEL flangia quadrata <i>Element with probe holder COMEL square flange</i> <i>Resistance avec sonde COMEL bride carree</i> <i>Elemento con soporte sonda COMEL brida quadrada</i>				
Q.1050		1/4	1650	133	GT Ø 6mm



Cod.	Descrizione	R	W	L = mm	O
Q.1100	Elemento CASOLI (faston) <i>Element CASOLI (faston)</i> <i>Resistance CASOLI (faston)</i> <i>Elemento CASOLI (faston)</i>	1/4	1500	180	2
Q.1110		1/4	2000	180	2



Q.1150	Elemento <i>Element</i> <i>Resistance</i> <i>Elemento</i>	1/4	2000	180	2
--------	--	-----	------	-----	---



Q.1200	Elemento STIROVAP <i>Element STIROVAP</i> <i>Resistance STIROVAP</i> <i>Elemento STIROVAP</i>	1/4	1500	160	
Q.1210		1/4	2200	160	



Cod.	Descrizione	R	W	L = mm	O
------	-------------	---	---	--------	---

Tortiglione
Spiral heating element
Resistance tortillon
Elemento circular

Q.1300		3/8	1650	100	
Q.1310		3/8	2000	100	
Q.1320		3/8	2700	100	
Q.1330		3/8	3000	125	
Q.1340		3/8	3300	125	
Q.1350		3/8	3500	125	



Spirale
Flat spiral heating element
Resistance spirale
Elemento espiral

Q.1400		3/8	1600	50	
Q.1410		3/8	2000	50	
Q.1420		3/8	2500	50	
Q.1430		3/8	3000	50	
Q.1440		3/8	3500	50	



Legenda abbreviazioni
Abbreviations list
Liste d'abbreviations
Lista de abreviaciones

\emptyset = mm.	diámetro flangia flange diameter diamètre bride diámetro brida	l = mm.	interasse fori distance between holes centre distance entre le trous distancia entre agujero	$GT \emptyset$	Diametro porta sonda Probe holder diameter Diamètre porte sonde Diametro soporte sonda
Δ = mm.	flangia triangolare triangular flange bride triangulaire brida triangular	$\emptyset f$ = mm.	diámetro fori holes diameter diamètre diámetro		
L = mm.	lunghezza length longueur largo	R	raccordo fitting raccord racor		

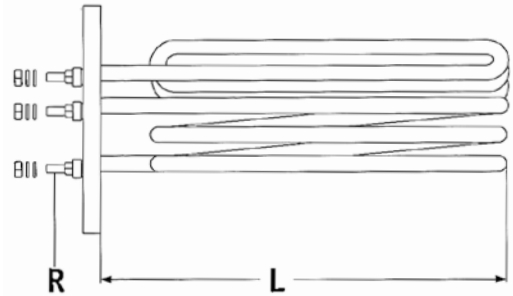
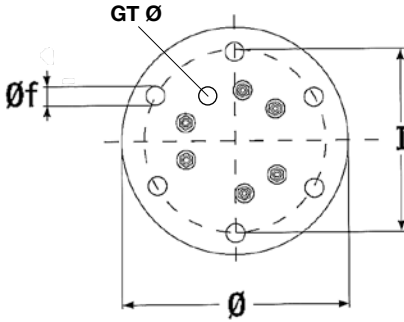

Cod.	Descrizione	W	\emptyset	L	$\emptyset f$	I
	Resistenza con flangia 4 fori <i>Heating element with flange 4 holes</i> <i>Resistance a bride 4 trous</i> <i>Resistencia con brida 4 foros</i>					
Q.1500	CAMPTEL	2800	110	160	10	95
Q.1510	CAMPTEL	3500	110	160	10	95
Q.1520	CAMPTEL	5000	110	180	10	95
Q.1525	CAMPTEL	7000	110	180	10	95



Cod.	Descrizione	W	Ø	L	Øf	I
	Resistenza con flangia 6 fori <i>Heating element with flange 6 holes</i> <i>Resistance a bride 6 trous</i> <i>Resistencia con brida 6 foros</i>					
Q.1530	CAMPTEL	5000	152	250	15	125
Q.1540	CAMPTEL	6500	152	250	15	125
Q.1550	CAMPTEL	7500	152	250	15	125
Q.1560	CAMPTEL	10000	152	280	15	125
Q.1570	CAMPTEL	12000	152	280	15	125
Q.1580	CAMPTEL	15000	152	280	15	125



	Resistenza con flangia 6 fori <i>Heating element with flange 6 holes</i> <i>Resistance a bride 6 trous</i> <i>Resistencia con brida 6 foros</i>					
Q.1590	CAMPTEL	10000	195	280	15	165
Q.1600	CAMPTEL	12000	195	280	15	165
Q.1610	CAMPTEL	15000	195	280	15	165



	Resistenza con flangia 6 fori <i>Heating element with flange 6 holes</i> <i>Resistance a bride 6 trous</i> <i>Resistencia con brida 6 foros</i>					
Q.1700	GHIDINI	2700	130	155	10	110
Q.1710	GHIDINI	3000	130	155	10	110
Q.1720	GHIDINI	3500	130	180	10	110
Q.1730	GHIDINI	4500	130	180	10	110
Q.1740	GHIDINI	6000	130	180	10	110



	Resistenza con flangia 6 fori <i>Heating element with flange 6 holes</i> <i>Resistance a bride 6 trous</i> <i>Resistencia con brida 6 foros</i>					
Q.1750	GHIDINI	5500	147	250	12	120
Q.1760	GHIDINI	7000	147	250	12	120
Q.1770	GHIDINI	8500	147	250	12	120
Q.1780	GHIDINI	10000	147	250	12	120
Q.1790	GHIDINI	12000	147	280	12	120
Q.1800	GHIDINI	15000	147	370	12	120
Q.1810	GHIDINI	18000	147	370	12	120
Q.1820	GHIDINI	20000	147	450	12	120
Q.1830	GHIDINI	24000	147	450	12	120
Q.1840	GHIDINI	25000	147	450	12	120
Q.1850	GHIDINI	27000	147	450	12	120
Q.1860	GHIDINI	30000	147	450	12	120



Cod.	Descrizione	W	Ø	L	Øf	I
	Tortiglione con flangia 4 fori <i>Spiral heating element with flange 4 holes</i> <i>Tortillon a bride 4 trous</i> <i>Resistencia circular con brida 4 foros</i>					
Q.1900	CAMPTEL	1500	110	100	10	96
Q.1910	CAMPTEL	2800	110	100	10	96



	Resistenza con flangia 6 fori <i>Heating element with flange 6 holes</i> <i>Resistance a bride 6 trous</i> <i>Resistencia con brida 6 foros</i>					
Q.2000	COCCHI	2500	130	160	10	105
Q.2010	COCCHI	2600	130	140	10	105
Q.2020	BARBANTI	3000	130	160	10	105
Q.2030	COCCHI	3500	130	180	10	105
Q.2040	COCCHI	3600	130	140	10	105
Q.2050	BARBANTI	3900	130	160	10	105
Q.2060	COCCHI	4700	130	180	10	105
Q.2070	COCCHI	6000	130	180	10	105



	Resistenza con flangia 8 fori <i>Heating element with flange 8 holes</i> <i>Resistance a bride 8 trous</i> <i>Resistencia con brida 8 foros</i>					
Q.2100	BARBANTI	3000	152	180	10	125
Q.2110	BARBANTI	6000	152	200	10	125
Q.2120	BARBANTI	7500	152	200	10	125



	Resistenza con flangia 6 fori <i>Heating element with flange 6 holes</i> <i>Resistance a bride 6 trous</i> <i>Resistencia con brida 6 foros</i>					
Q.2200	RENZACCI - REALSTAR	6000	152	200	9	128
Q.2210	RENZACCI - REALSTAR	8500	152	200	9	128
Q.2220	RENZACCI - REALSTAR	9000	152	200	9	128



Cod.	Descrizione	W	Ø	L	Øf	I
	Resistenza con flangia 4 fori <i>Heating element with flange 4 holes</i> <i>Resistance a bride 4 trous</i> <i>Resistencia con brida 4 foros</i>					
Q.2300	STIROVAP	3000	120	160	9	102
Q.2310	STIROVAP	4400	120	160	9	102



	Resistenza con flangia 6 fori <i>Heating element with flange 6 holes</i> <i>Resistance a bride 6 trous</i> <i>Resistencia con brida 6 foros</i>					
Q.2350	COVEMAT	3500	150	210	11	120
Q.2360	COVEMAT	5000	150	210	11	120



	Resistenza con flangia 8 fori con guarnizione <i>Heating element with flange 8 holes with gasket</i> <i>Resistance a bride 8 trous avec joint</i> <i>Resistencia con brida 8 foros con guarnicion</i>					
Q.2400	TREVIL	2000	110	8	85	
Q.2410	TREVIL	4000	110	8	85	
Q.2420	TREVIL	6000	110	8	85	



Q.2400



Q.2410



Q.2420

	Resistenza con flangia 4 fori <i>Heating element with flange 4 holes</i> <i>Resistance a bride 4 trous</i> <i>Resistencia con brida 4 foros</i>					
Q.2450	SARTITALIA	3600	120	175	10	100
Q.2455	SARTITALIA	4500	120	175	10	100
Q.2460	SARTITALIA	6000	120	175	10	100



Cod.	Descrizione	W	Ø	L	Øf	I
	Resistenza con flangia 4 fori con portasonda <i>Heating element with flange 4 holes with probe holder</i> <i>Resistance a bride 4 trous avec porte sonde</i> <i>Resistencia con brida 4 foros con soporte sonda</i>					
Q.2480	SARTITALIA	3600	120	175	10	100 GT Ø 6mm
Q.2485	SARTITALIA	4500	120	175	10	100 GT Ø 6mm
Q.2490	SARTITALIA	6000	120	175	10	100 GT Ø 6mm



	Resistenza con flangia 2 fori <i>Heating element with flange 2 holes</i> <i>Resistance a bride 2 trous</i> <i>Resistencia con brida 2 foros</i>					
Q.2500	REVERBERI	1000	92x35	172	7	



	Resistenza con flangia 4 fori con portasonda <i>Heating element with flange 4 holes with probe holder</i> <i>Resistance a bride 4 trous avec porte sonde</i> <i>Resistencia con brida 4 foros con soporte sonda</i>					
Q.2600	REVERBERI	1500	110	180	9	85 GT Ø 6mm
Q.2610	REVERBERI	3300	110	180	9	85 GT Ø 6mm



	Resistenza con flangia 6 fori con portasonda <i>Heating element with flange 6 holes with probe holder</i> <i>Resistance a bride 6 trous avec porte sonde</i> <i>Resistencia con brida 6 foros con soporte sonda</i>					
Q.2620	REVERBERI	5000	150	200	12	121 GT Ø 8mm



Cod.	Descrizione	W	Ø	L	Øf	I
	Resistenza con flangia 4 fori <i>Heating element with flange 4 holes</i> <i>Resistance a bride 4 trous</i> <i>Resistencia con brida 4 foros</i>					
Q.2650	BIELLE	4500	110	110	9	95
Q.2660	BIELLE	3500	110	175	9	95
Q.2665	BIELLE	4500	110	175	9	95
Q.2670	BIELLE	5500	110	175	9	95
Q.2675	BIELLE	7500	110	175	9	95
Q.2680	BIELLE	9000	110	235	9	95



Q.2650



	Resistenza con flangia smussata 4 fori <i>Element with truncated flange 4 holes</i> <i>Resistance a bride emousse 4 trous</i> <i>Resistencia con brida biselada 4 foros</i>					
Q.2700	MAX STIR	1100	90	165	9	70 GT Ø 8mm
Q.2710	MAX STIR	1500	90	165	9	70 GT Ø 8mm



	Resistenza con flangia 4 fori <i>Heating element with flange 4 holes</i> <i>Resistance a bride 4 trous</i> <i>Resistencia con brida 4 foros</i>					
Q.2750	MAX STIR	1000	75	155	9	55



	Resistenza con flangia rettangolare 6 fori <i>Heating element with rectangular flange 6 holes</i> <i>Resistance a bride rectangulaire 6 trous</i> <i>Resistencia con brida rectangular 6 foros</i>					
Q.2800	MAX STIR	3900	165x70	140	10	
Q.2810	MAX STIR	4500	165x70	140	10	



Cod.	Descrizione	W	∅	L	∅f	I
	Resistenza con flangia quadrata 6 fori <i>Heating element with square flange 6 holes</i> <i>Resistance a bride carree 6 trous</i> <i>Resistencia con brida cuadrada 6 foros</i>					
Q.2900	SUSSMAN	9000	120x120	265	10	
Q.2910	SUSSMAN	12000	120x120	265	10	
Q.2920	SUSSMAN	15000	120x120	265	10	
Q.2930	SUSSMAN	18000	120x120	265	10	



	Resistenza con flangia quadrata 4 fori con portasonda <i>Heating element with square flange 4 holes with probe holder</i> <i>Resistance a bride carree porte avec sonde 4 trous</i> <i>Resistencia con brida cuadrada 4 foros con soporte sonda</i>					
Q.3000	COMEL	1650	85x85	133	10	GT ∅ 7mm



	Resistenza alluminio con flangia quadrata 4 fori LT 5 <i>Alluminium heating element with square flange 4 holes LT 5</i> <i>Resistance aluminium a bride carree 4 trous LT 5</i> <i>Resistencia aluminio con brida cuadrada 4 foros LT 5</i>					
Q.3010	COMEL	1800	85x85	148	10	



Cod. Descrizione W Δ L Øf I

Resistenza con flangia triangolare elemento piegato
Heating element with triangular flange bent element
Resistance a bride triangulaire element plie
Resistencia con brida triangular elemento doblado

Q.3100 **CASOLI** 1400 78 230 12



Resistenza con flangia triangolare
Heating element with triangular flange
Resistance a bride triangulaire
Resistencia con brida triangular

Q.3200 1000 65 150 9
 Q.3210 1500 65 170 9
 Q.3220 1500 78 170 9



Resistenza con flangia triangolare con portasonda
Heating element with triangular flange with probe holder
Resistance a bride triangulaire avec porte sonde
Resistencia con brida triangular con soporte sonda

Q.3300 1500 78 170 10 GT Ø 7mm
 Q.3350 **BIELLE** 2000 78 220 10 GT Ø 7mm



Q.3300

Q.3350

Resistenza con flangia triangolare con portasonda
Heating element with triangular flange with probe holder
Resistance a bride triangulaire avec porte sonde
Resistencia con brida triangular con soporte sonda

Q.3370 **SARTALIA** 1600 78 165 10 GT Ø 7mm



Résistances et pièces détachées pour machines à repasser
 Resistencias y recambios para máquinas de planchar

PRIMA



Cod.	Descrizione	R	W	L
	Resistenza a tappo filettato <i>Heating element on threaded cap</i> <i>Resistance a bouchon filete</i> <i>Resistencia de tapon con rosca</i>			
Q.3400		1"	1000	150
Q.3405		1"	1200	150
Q.3410		1"	1500	170
Q.3420		1"	2000	170



	Resistenza a tappo filettato con portasonda <i>Heating element on threaded cap with probe holder</i> <i>Resistance a bouchon filete avec porte sonde</i> <i>Resistencia de tapon con rosca con soporte sonda</i>				
Q.3490		1"	1000	150	GT Ø 7mm
Q.3500		1"	1200	150	GT Ø 7mm



	Resistenza a tappo filettato <i>Heating element on threaded cap</i> <i>Resistance a bouchon filete</i> <i>Resistencia de tapon con rosca</i>			
Q.3600		1" 1/4	900	150
Q.3610		1" 1/4	1500	170
Q.3620		1" 1/4	2000	170
Q.3630		1" 1/4	2500	170



Cod.	Descrizione	R	W	L
------	-------------	---	---	---

Resistenza a tappo filettato
Heating element on threaded cap
 Resistance a bouchon filete
 Resistencia de tapon con rosca

Q.3680	BARBANTI	1"1/4	1000	230
--------	-----------------	-------	------	-----



Resistenza a tappo filettato con portasonda
Element on threaded cap with probe holder
 Resistance a bouchon filete avec porte sonde
 Resistencia de tapon con rosca con soporte sonda

Q.3790		1 1/4"	900	170
Q.3800		1 1/4"	1500	170



Q.3790



Q.3800



Résistances et pièces détachées pour machines à repasser
 Resistencias y recambios para máquinas de planchar

PRIMA



Cod.	Descrizione	W
Q.3900	Resistenza completa <i>Complete heating element</i> <i>Resistance complete</i> <i>Resistencia completa</i>	
Q.3910	DOMINA TREVIL FABER TREVIL	700 1400



Q.4000	Resistenza alluminio 3 fori <i>Alluminium heating element 3 holes</i> <i>Resistance aluminium 3 trous</i> <i>Resistencia aluminio 3 foros</i>	1000	Ø 150mm
Q.4010	GHIDINI - PONY - CAMPTEL GHIDINI - CAMPTEL	1500	Ø 180mm



Q.4000

Q.4010

Q.4045	Resistenza a fascia <i>Band heating element</i> <i>Resistance a collier</i> <i>Resistencia banda</i>	Ø 160mm	1000	H=45 mm
Q.4050	BIEFFE BIEFFE	Ø 160mm	1300	H=60 mm

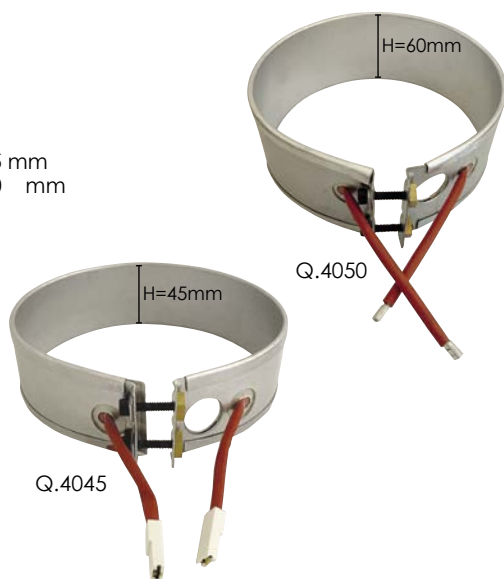

Q.4045

Q.4050

Cod. Descrizione

Flangia quadrata 4 fori
Squared flange 4 holes
Bride carree 4 trous
Brida cuadrada 4 foros

Q.4090 **COMEL** 85x85mm



Flangia 4 fori
Flange 4 holes
Bride 4 trous
Brida 4 foros

Q.4100 **STIROVAP** Ø 120mm



Flangia 6 fori
Flange 6 holes
Bride 6 trous
Brida 6 foros

Q.4110 **PONY** Ø 160mm
 Q.4120 **PONY** Ø 180mm
 Q.4130 **PONY** Ø 200mm



Q.4110

Q.4120

Q.4130

Flangia 6 fori
Flange 6 holes
Bride 6 trous
Brida 6 foros

Q.4140 **CAMPTEL** Ø 195mm - 6 internal holes
 Q.4150 **CAMPTEL** Ø 195mm - 7 internal holes
 Q.4160 **CAMPTEL** Ø 195mm - 12 internal holes



Q.4140

Q.4150

Q.4160

Cod. **Descrizione**

Guarnizione per elemento
Gasket for heating element
Joint pour resistance element
Guarnicion para elemento

Q.4300 1/4"
Q.4310 3/8"
Q.4312 1/2"
Q.4315 3/8" PTFE



Q.4300



Q.4310



Q.4312



Q.4315

Guarnizione per resistenza
Gasket for heating element
Joint pour resistance
Guarnicion para resistencia

Q.4317 3/4"
Q.4320 1"
Q.4325 1" PTFE
Q.4330 1"1/4
Q.4335 1"1/4 PTFE
Q.4340 1"1/2



Q.4317



Q.4320



Q.4325



Q.4330



Q.4335



Q.4340

Guarnizione rettangolare 6 fori
6 holes rectangular gasket
Joint rectangulaire 6 trous
Guarnicion rectangular 6 foros

Q.4700 **MAX STIR**



Guarnizione smussata 4 fori
4 holes truncated gasket
Joint emousse 4 trous
Guarnicion biselada 4 foros

Q.4730 **MAX STIR**



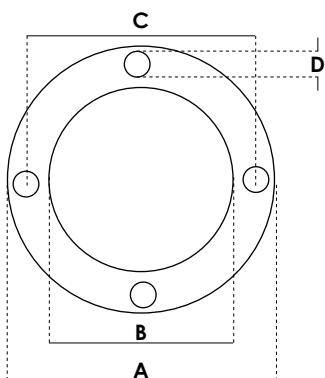
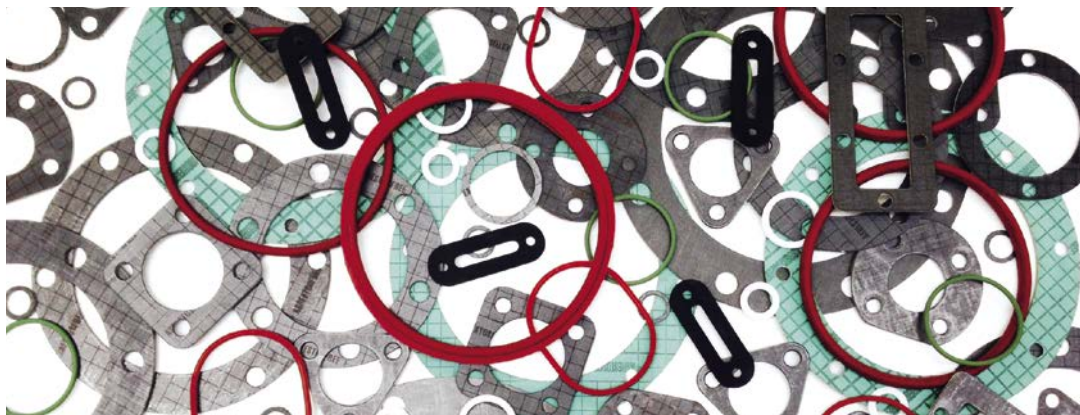

	A	B	C	D	
Q.4500	110	76	94	10	CAMPTEL BIELLE
Q.4503	110	67	85	9	REVERBERI
Q.4505	121	72	100	9	SARTITALIA
Q.4510	120	85	102	9	STIROVAP

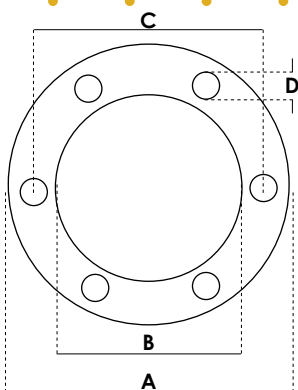

	A	B	C	D	
Q.4515	130	82	105	11	COCCHI BARBANTI
Q.4520	127	81	110	10	GHIDINI
Q.4525	132	78	110	10	CASOLI
Q.4530	146	97	120	12	GHIDINI
Q.4535	151	85	120	11,5	COMEL
Q.4540	150	100	125	15	CAMPTEL
Q.4545	160	96	135	12	COMEL
Q.4550	162	115	140	13	PONY
Q.4560	181	137	160	12	PONY
Q.4570	195	133	164	14	CAMPTEL
Q.4580	200	145	181	13	PONY

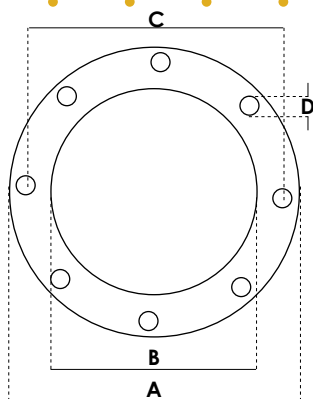

	A	B	C	D	
Q.4590	222	160	198	12	BM
Q.4600	260	185	232	16	BM
Q.4920	110	65	87	9	TREVIL

Cod.	Descrizione
	Guarnizione triangolare 3 fori 3 Holes triangular gasket Joint triangulaire 3 trous Guarnicion triangular 3 foros

Q.4710	65mm
Q.4720	78mm



Q.4710



Q.4720

Q.4740	Guarnizione quadrata 4 fori 4 Holes square gasket Joint carree 4 trous Guarnicion cuadrada 4 foros COMEL 82x82mm
--------	---



Q.4750	Guarnizione caldaia LT 5 Gasket for LT 5 steam generator Joint pour chaudiere LT 5 Guarnicion para generator de vapor LT 5 COMEL 87x87mm
--------	---



Cod.

Descrizione

Guarnizione silicone
Silicon gasket
Joint silicone
Guarnición de silicona

Q.4900
Q.4910

**REVERBERI
TREVIL**



Q.4900



Q.4910

Guarnizione silicone
Silicon gasket
Joint silicone
Guarnición de silicona

Q.4930
Q.4940

GHIDINI - PONY - CAMPTEL Ø 150mm
STIR 17/30/40 Ø 180mm



Q.4930



Q.4940

Guarnizione adesiva universale per flange
Adhesive universal gasket for flanges
Joint autocollant universel pour brides
Guarnición adhesiva universal para bridas

Q.5000

10x3mm PTFE



Pasta rossa silconica alte temperature
Red gasket paste high temperature
Pate a joint rouge haute temperature
Pasta roja para juntas alta temperatura

Q.5100

300°C (75ml)



Résistances et pièces détachées pour machines à repasser
Resistencias y recambios para máquinas de planchar

PRIMA

Cod.	Descrizione	R	W	L=mm
	Resistenza con flangia Ø 95mm 6 fori con portasonda <i>Heating element with flange Ø 95mm 6 holes with probe holder</i> <i>Resistance a bride Ø 95mm 6 trous avec porte sonde</i> <i>Resistencia con brida Ø 95mm 6 foros con soporte sonda</i>			
R.0010			4500	250 GT Ø6 mm
R.0020			6000	250 GT Ø6 mm
R.0030			9000	250 GT Ø6 mm



	Resistenza a tappo filettato <i>Heating element on threaded cap</i> <i>Resistance a bouchon filete</i> <i>Resistencia de tapon con rosca</i>			
R.0100		1"1/2	1500	480
R.0110		1"1/2	2000	480
R.0120		1"1/2	2500	480
R.0130		1"1/2	3000	480
R.0140		1"1/2	4000	480



	Resistenza a tappo filettato con portasonda <i>Heating element on threaded cap with probe holder</i> <i>Resistance a bouchon filete avec porte sonde</i> <i>Resistencia de tapon con rosca con soporte sonda</i>			
R.0200		1"1/2	4000	400 GT Ø6 mm
R.0210		1"1/2	6000	400 GT Ø6 mm
R.0220		1"1/2	7500	480 GT Ø6 mm
R.0230		1"1/2	9000	600 GT Ø6 mm



	Resistenza a tappo filettato <i>Heating element on threaded cap</i> <i>Resistance a bouchon filete</i> <i>Resistencia de tapon con rosca</i>			
R.0300		2"	4000	400
R.0310		2"	6000	600
R.0320		2"	8000	600



Cod. **Descrizione** **R** **W** **L=mm**

Resistenza a tappo filettato con portasonda
Heating element on threaded cap with probe holder
Resistance a bouchon filete avec porte sonde
Resistencia de tapon con rosca con soporte sonda

R.0400		2"	4000	400	GT Ø6 mm
R.0410		2"	6000	600	GT Ø6 mm
R.0420		2"	8000	600	GT Ø6 mm



Resistenza a tappo filettato con portasonda
Heating element on threaded cap with probe holder
Resistance a bouchon filete avec porte sonde
Resistencia de tapon con rosca con soporte sonda

R.0500	RENZACCI	2"	5000	260	GT Ø5 mm
R.0510	RENZACCI	2"	6000	260	GT Ø5 mm



Resistenza a tappo filettato
Heating element on threaded cap
Resistance a bouchon filete
Resistencia de tapon con rosca

R.0600		3/4"	1500	500	
R.0610		3/4"	2000	500	
R.0620		3/4"	2500	500	
R.0630		3/4"	2500	850	
R.0640		3/4"	3000	850	



Resistenza a tappo filettato con portasonda
Heating element on threaded cap with probe holder
Resistance a bouchon filete avec porte sonde
Resistencia de tapon con rosca con soporte sonda

R.0700		3/4"	1500	500	GT Ø6 mm
R.0710		3/4"	2000	500	GT Ø6 mm
R.0720		3/4"	2500	500	GT Ø6 mm
R.0730		3/4"	2500	850	GT Ø6 mm
R.0740		3/4"	3000	850	GT Ø6 mm



Résistances et pièces détachées pour machines de nettoyage à sec
 Resistencias y recambios para máquinas de lavado a seco

PRIMA

R

R

Cod.	Descrizione	R	W	L=mm
R.0800	Resistenza con flangia ovale <i>Heating element with oval flange</i> <i>Resistance a bride ovale</i> <i>Resistencia con brida oval</i>			
	SOCOLMATIC		3000	



R.0900		1"1/4	1500	380
R.0910		1"1/4	2000	380
R.0920		1"1/4	2000	450
R.0930		1"1/4	2500	450
R.0940		1"1/4	2500	800
R.0950		1"1/4	3000	550
R.0960		1"1/4	3000	800

Resistenza olio a tappo filettato
Oil heater on threaded cup
Resistance huile a bouchon filete
Resistencia aceite de tapon con rosca



	Δ =mm	W	L=mm
R.1000	78	1500	380
R.1010	78	2000	380
R.1020	78	2500	450
R.1030	78	3000	550
R.1040	78	3000	700
R.1050	78	3000	800

Resistenza olio con flangia triangolare
Oil heater with triangular flange
Resistance huile a bride triangulaire
Resistencia aceite con brida triangular



R.1100	1/4"	1100	230
R.1110	1/4"	1400	280

Resistenza soffietto
Bellows heating element
Resistance soufflets
Resistencia fuelle



Cod.	Descrizione	R	W	L=mm
	Resistenza soffiato <i>Bellows heating element</i> <i>Resistance soufflets</i> <i>Resistencia fuelle</i>			
R.1120		3/8"	1750	280
R.1130		3/8"	2000	280
R.1140		3/8"	2660	280



	Resistenza alettata <i>Finned heating element</i> <i>Resistance ailettes</i> <i>Resistencia aletada</i>			
R.1200		1/4"	550	280
R.1210		1/4"	840	260
R.1230		1/4"	1000	285
R.1240		1/4"	1500	540



	Resistenza alettata <i>Finned heating element</i> <i>Resistance ailettes</i> <i>Resistencia aletada</i>			
R.1250		3/8"	2000	730



	Resistenza alettata <i>Finned heating element</i> <i>Resistance ailettes</i> <i>Resistencia aletada</i>			
R.1260		3/4"	600	360
R.1270		3/4"	900	400



Cod.

Descrizione

Termostato di sicurezza riarmo automatico
Automatic-reset safety thermostat
Thermostat de surete avec rearmement automatique
Termostato de seguridad rearme automatico



S.0010	80°C
S.0020	90°C
S.0030	130°C
S.0040	140°C
S.0050	150°C
S.0060	160°C
S.0070	170°C

Termostato di sicurezza riarmo manuale
Manual-reset safety thermostat
Thermostat de surete avec rearmement manuel
Termostato de seguridad rearme manual



S.0200	130°C
S.0210	140°C
S.0220	150°C
S.0230	160°C
S.0240	170°C

Termostato di sicurezza a vite riarmo automatico
Automatic-reset safety thermostat with screw
Thermostat de surete a vis rearmement automatique
Termostato de seguridad con tornillo rearme automatico



S.0400	80°C
S.0410	90°C
S.0420	130°C
S.0430	140°C
S.0440	150°C
S.0450	160°C
S.0460	170°C

Termostato di sicurezza a vite riarmo manuale
Manual-reset safety thermostat with screw
Thermostat de surete a vis rearmement manuel
Termostato de seguridad con tornillo rearme manual



S.0510	145°C
S.0530	165°C

Termostato di sicurezza doppio
Safety thermostat double
Thermostat de surete double
Termostato de seguridad doble



S.0550	STIROLUX	155°C - 180°C
--------	-----------------	---------------

Cod. Descrizione

Termoregolatore con sonda
Thermoregulator with probe
Thermoregulateur avec sonde
Termoregulador con sonda

S.0600	30 - 90°C	L=1000mm
S.0610	30 - 120°C	L=1000mm
S.0620	50 - 200°C	L=1000mm
S.0630	50 - 300°C	L=1000mm



Termoregolatore con sonda senza gambo
Thermoregulator with probe without stem
Thermoregulateur avec sonde sans tige
Termoregulador con sonda sin vastago

S.0700	0 - 200°C
--------	-----------



Termoregolatore con sonda
Thermoregulator with probe
Thermoregulateur avec sonde
Termoregulador con sonda

S.0720	30 - 120°C	L=2000mm
S.0750	50 - 300°C	L=2500mm
S.0770	30 - 90°C	L=3000mm



Termoregolatore SIMMERSTAT
Thermoregulator SIMMERSTAT
Thermoregulateur SIMMERSTAT
Termoregulador SIMMERSTAT

S.0800	0 - 100°C
--------	-----------



Cod. **Descrizione**

T.0010 Pistola nebulizzatrice
 Spraying gun
 Pistolet pulverisateur d'eau
 Pistola de pulverizado

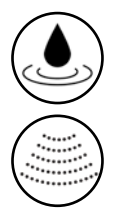

T.0600



T.0610



T.0615



T.0620

T.0030 Pistola nebulizzatrice 1 entrata
 1-connection spraying gun
 Pistolet pulverisateur d'eau 1 entree
 Pistola de pulverizado 1 entrada

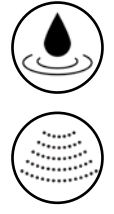

T.0700

Cod. Descrizione

T.0150 Pistola nebulizzatrice-smacchiatrice 2 entrate
 2-connections spraying-spotting gun
 Pistolet pulverisateur d'eau-detacheur 2 entrees
 Pistola de pulverizado-desmanchadora 2 entradas



T.0250 Pistola smacchiatrice elettrica
 Electric spotting gun
 Pistolet detacheur electrique
 Pistola desmanchadora electrica
 "KSK"



T.1080



T.1090

T.1300 Serbatoio nylon
 Nylon tank
 Reservoir nylon
 Deposito nylon
 500cc 1/4"



T.1300

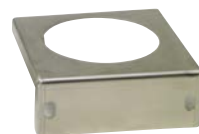

T.1310

T.1310 Supporto serbatoio nylon
 Support for nylon tank
 Support pour reservoir nylon
 Soporte para deposito nylon

Cod. **Descrizione**

T.0040 "SMP"

Pistola nebulizzatrice 2 entrate
2-connections spraying gun
Pistolet pulverisateur d'eau 2 entrees
Pistola de pulverizado 2 entradas

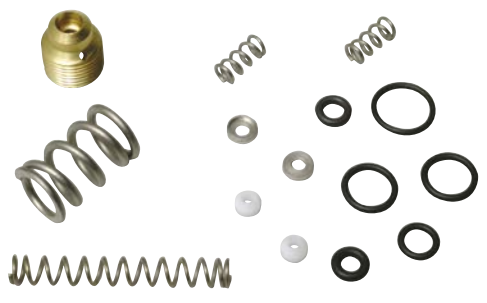
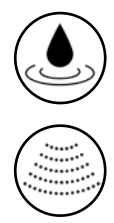

T.0800



T.0810

T.0050 "HYDRO"

Pistola nebulizzatrice 2 entrate
2-connections spraying gun
Pistolet pulverisateur d'eau 2 entrees
Pistola de pulverizado 2 entradas

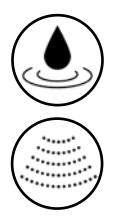

T.0900



T.0910

Cod. Descrizione

Pistola smacchiatrice 2 entrate
 2-connections spotting gun
 Pistolet detacheur 2 entrees
 Pistola desmanchadora 2 entradas

T.0200 "SMT"

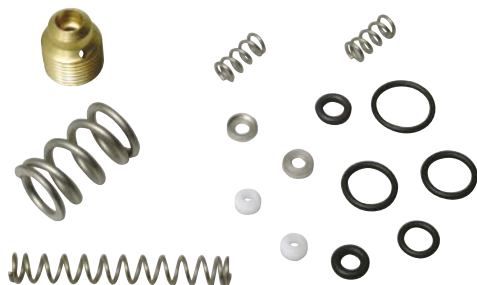
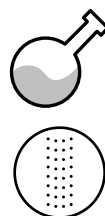

T.0800



T.0820

Pistola smacchiatrice 2 entrate
 2-connections spotting gun
 Pistolet detacheur 2 entrees
 Pistola desmanchadora 2 entradas

T.0210 "DRY"

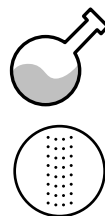

T.0900



T.0920

Cod.

Descrizione

Pistola vapore 1 micro
Steam gun 1 microswitch
Pistolet vapeur 1 microinterrupteur
Pistola vapor 1 micro



T.0310

"2F"



Pistola vapore 1 micro con beccuccio piatto
intercambiabile
Steam gun 1 microswitch with flat
interchangeable nozzle
Pistolet vapeur 1 microinterrupteur avec
buse interchangeable plat
Pistola vapor 1 micro con piton plano
intercambiabile



T.0320

"2F"



Pistola vapore 1 micro con beccuccio tondo
intercambiabile
Steam gun 1 microswitch with round
interchangeable nozzle
Pistolet vapeur 1 microinterrupteur avec
buse ronde interchangeable plat
Pistola vapor 1 micro con piton redondo
intercambiabile



T.0330

"2F"



T.1100



T.1110



T.1120

Cod. Descrizione

Pistola aria vapore 2 micro
Steam air gun 2 microswitches
Pistolet air et vapeur 2 microinterrupteurs
Pistola aire y vapor 2 micro

T.0410 "2F"



Pistola aria vapore 2 micro con beccuccio
 piatto intercambiabile
Steam air gun 2 microswitches with flat
interchangeable nozzle
Pistolet air et vapeur 2 microinterrupteurs
avec buse interchangeable plat
Pistola aire y vapor 2 micro con piton plano
intercambiabile

T.0420 "2F"



Coprimicro per pistola "2F"
Cap for microswitch gun "2F"
Cache pour microinterrupteur de pistolet "2F"
Cubre micro para pistola "2F"

T.1130 GREEN
 T.1140 WHITE
 T.1150 RED





T.1130





T.1140



T.1150

Cod.	Descrizione	
T.0300	Pistola vapore 1 micro Steam gun 1 microswitch Pistolet vapeur 1 microinterrupteur Pistola vapor 1 micro	 

T.0400	Pistola aria vapore 2 micro Steam air gun 2 microswitches Pistolet air et vapeur 2 microinterrupteurs Pistola aire y vapor 2 micro	  
--------	---	--

T.0430	Pistola aria vapore 2 micro Steam air gun 2 microswitches Pistolet air et vapeur 2 microinterrupteurs Pistola aire y vapor 2 micro	  
--------	---	--



T.1200



T.1210



T.1220



T.1230

Cod.

Descrizione

T.0230

Pistola meccanica comando a pedale
Mechanic pedal gun
Pistolet mécanique commande pedale
Pistola mecanica mando a pedal



T.0500

Pistola meccanica a leva per asciugare
Drying lever mechanic gun
Pistolet mécanique a levier pour secher
Pistola mecanica de leva para secar



T.0510

Pistola aria per asciugare (ugello a lama)
Drying air gun (blade nozzle)
Pistolet air pour secher (buse lame)
Pistola de aire para secar (boquilla de chorro recto)



T.0520

Pistola aria per pulire (ugello tondo)
Cleaning air gun (round nozzle)
Pistolet air pour nettoyer (buse conique)
Pistola de aire para limpieza (boquilla de chorro redondo)



Pistolets, brosses vaporisantes et pièces détachées
Pistolas, cepillos vaporisantes y recambios

PRIMA

Cod.	Descrizione	
------	-------------	--

T.1420	<p>Spazzola vaporizzante Steam brush Brosse vaporisante Cepillo vaporizador</p> <p>"SPEEDY"</p>	
--------	---	---



T.1450	<p>Spazzola vaporizzante setole morbide Steam brush with soft bristles Brosse vaporisante avec crin douce Cepillo vaporizador con cerda blanda</p> <p>"SPEEDY" SOFT BRISTLES</p>	
--------	--	---



T.1460	<p>Spazzola vaporizzante stirante Ironing steel steam brush Brosse vaporisante avec semelle a repasser en acier Cepillo vaporizador y planchado</p> <p>"SPEEDY"</p>	
--------	---	--



T.1615



T.1700 500W

Cod. Descrizione



T.1710



T.1720



T.1800



T.1810



T.1820



T.1830



T.1840



T.1850



T.1870



T.1855 210°C



T.1860 170°C

Pistolets, brosses vaporisantes et pièces détachées
Pistolas, cepillos vaporisantes y recambios

PRIMA

Cod. Descrizione

T.1470

Spazzola vaporizzante "LEGGERA"
Steam brush "LIGHT"
Brosse vaporisante "LEGERE"
Cepillo vaporizador "LIGERO"



T.2000

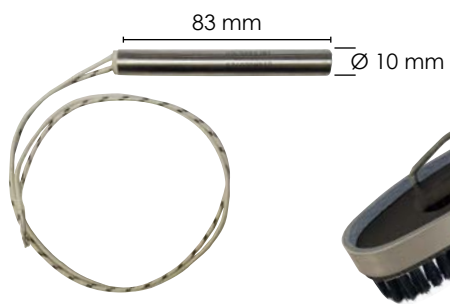

T.2010 400W



T.2020

T.1500

Surriscaldatore di vapore per spazzole
vaporizzanti
Steam super heater for brush
Surchauffeur de vapeur pour brosse vaporisante
Sobrecalentador de vapor para cepillo

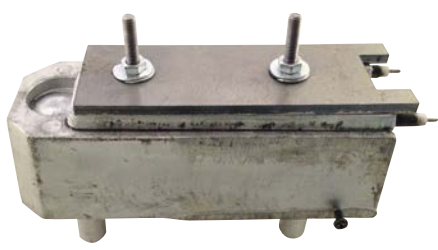

T.1550 1000W



T.1555 1000W



230V ≈ 50

Pistolets, brosses vaporisantes et pièces détachées
Pistolas, cepillos vaporizantes y recambios



PRIMA

Cod. Descrizione

U.0005 Pulifero
Iron cleaner
Nettoye fer
Limpiador fer



U.0010 "RUSTY"

Stick pulifero
Iron-cleaner stick
Stick nettoyage pour fer
Stick limpia plancha



U.0020

Tubetto pasta pulifero
Paste for iron-cleaner
Pate de nettoyage pour fer
Tubo pasta limpia plancha



U.0060 "EZ-OFF"

Rotolino nastro PTFE
PTFE band roll
Petit rouleau de ruban PTFE
Rollo de cinta PTFE



U.0070

Tubetto colla silicone
Silicon glue tube
Tube colle silicone
Tubo cola silicona



U.0070 "ELASTOSIL"

Cod. Descrizione

Scivolante puliferro
Sliding iron-cleaner
Nettoyant glissant pour fer
Deslizante limpia plancha

U.0030 "NET-FER" (400ml)



U.0030



U.0045

Appretto professionale spray
Professional spray starch
Professional amidon spray
Spray almidon profesional

U.0045 "OKAY" (500ml)

Spray togigrinze
Wrinkle remover spray
Spray enlève plis
Sprayquita pliegues

U.0050 "IGIEN STIRAFACILE" (300ml)

U.0055 "FAULTLESS" (280ml)

U.0057 "MIRACLE" (280ml)



U.0050



U.0055



U.0057

Polvere per pulizia nastri PTFE
PTFE belt cleaner powder
Poudre de nettoyage pour tapis en PTFE
Polvo para limpieza cintas en PTFE

U.0100 "ROLLAX" (250g)

Liquido spray per pulizia nastri PTFE
PTFE belt liquid spray cleaner
Liquide spray de nettoyage pour tapis en PTFE
Liquido spray para limpieza cintas en PTFE

U.0110 "SMOOTH FUSE" (500ml)

Spray per pulizia nastri in PTFE
PTFE belt spray cleaner
Spray de nettoyage pour tapis en PTFE
Spray para limpieza cintas en PTFE

U.0120 "TAKTER" (400ml)



U.0100



U.0110



U.0120

Cod.	Descrizione
U.0200	Appoggiaferro in gomma a quadretti <i>Squared iron rubber mat</i> <i>Tapis repose fer en caoutchouc quadrille</i> <i>Apoyaplancha de goma a cuadrillos</i>
U.0210	Appoggiaferro in gomma con piedini <i>Squared iron rubber mat with feet</i> <i>Tapis repose fer en caoutchouc avec pieds</i> <i>Apoyaplancha de goma con pies de realze</i>
U.0220	Appoggiaferro in gomma con bordo a "L" <i>"L" edge iron rubber mat</i> <i>Tapis repose fer en caoutchouc avec bords "L"</i> <i>Apoyaplancha de goma con borde a "L"</i>

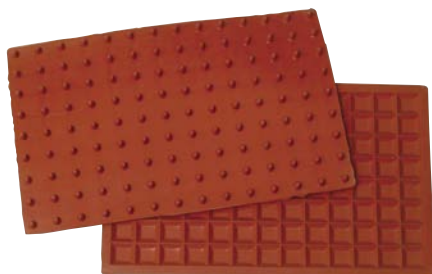

Cod. Descrizione

Appoggiaferro in silicone a quadretti
Squared iron silicon mat
Tapis repose fer en silicone quadrille
Apoyaplancha de silicona a cuadrillos

U.0230 220x135mm



Appoggiaferro in silicone con piedini
Squared iron silicon mat with feet
Tapis repose fer en silicone avec pieds
Apoyaplancha de silicona con pies de realze

U.0240 220x135mm

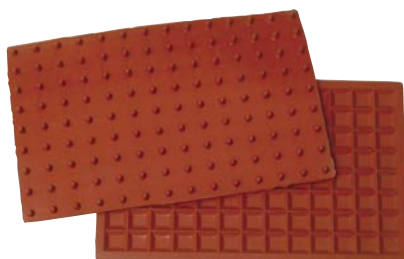

Appoggiaferro in silicone con bordo a "L"
"L" edge iron silicon mat
Tapis repose fer en silicone avec bords "L"
Apoyaplancha de silicona con borde a "L"

U.0250 255x150mm



Cod. **Descrizione**

Stuoia stiravelluto ad aghi acciaio
Steel needles mat for velvet
Natte repassage velours en aiguilles acier
Estera con pinchos de acero para planchar terciopelo

U.0400

700x300mm



Retina antilucido
No-shine mat
Toile grillage antilustre
Red antibrillo

U.0420

660x300mm



Estensore maniche in ferro rivestito silicone
Iron sleeve tensor covered of silicon
Extenseur de manche en acier revetu silicone
Estensor mangas de hierro revestido con silicona

U.0500

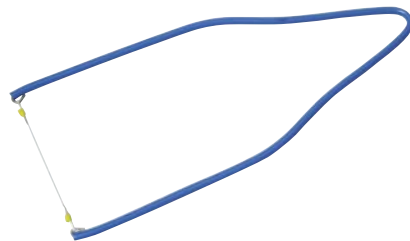

Estensore maniche
Sleeve tensor
Extenseur de manche
Estensor mangas

U.0505

"HAJO-FIX"



Cod.

Descrizione

U.0510 Tendimanica grande
Big sleeve tensor
Extenseur de manche grand
Tensamanga grande
570mm



U.0520 Tendimanica piccolo
Small sleeve tensor
Extenseur de manche petit
Tensamanga pequeño
400mm



U.0550 Molla ricambio per tendimanica
Spring for sleeve tensor
Ressort pour extenseur de manche
Muelle de recambio para tensamanga



U.0620 Braccetto stiramanica
Wood sleever
Jeannette en bois
Brazo con forma planchamanga
590x100x80mm

U.0630 560x125x100mm



U.0630



U.0620

Cod.

Descrizione

Platoncino a mano
Fabric beater
Taloche a main
Tampon de mano

U.0700

280x200mm



Guanto stiro proteggimano
Protective hand glove
Guant protection de la main
Guante de proteccion mano

U.0720

240x170mm



Stiracravatte
Ironing ties shape
Forme repasse cravates
Forma plancha corbatas

U.0730

620x70x25mm

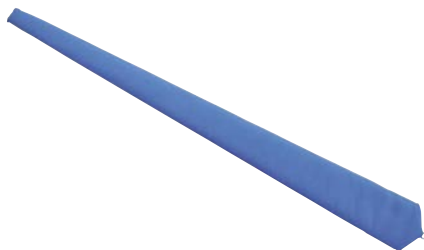

Serie manicali (4 pz)
Kit of sleeve pads (4 pcs)
Jeu de manchons (4 pcs)
Juego de mangueros para planchar mangas (4 pz)

U.0750



Cod.

Descrizione

U.0800 Antenna reggicavo con vite centrale
Cable support with central screw
Tige de suspension cable avec vis centrale
Antena portacable con tornillo central

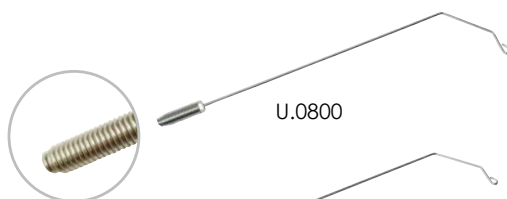

U.0810 Antenna reggicavo con spuntone
Cable support with clutch screw
Tige de suspension cable avec pointe
Antena portacable a encaje



U.0820 Antenna reggicavo con vite laterale
Cable support with lateral screw
Tige de suspension cable avec vis laterale
Antena portacable con tornillo lateral



U.0900 Molla rigida sospensione cavo
Rigid hanging cable spring
Ressort rigide de suspension cable
Muelle rigido suspencion cable



U.0910 Molla morbida sospensione cavo
Soft hanging cable spring
Ressort mou de suspension cable
Muelle ligero suspencion cable

U.0900 U.0910

U.0920 Forcella sospensione cavo
Fork for cable support
Fourche de suspension cable
Horquilla suspencion cable

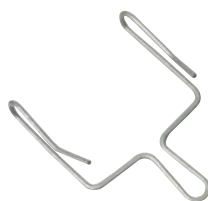

U.0950 Saliscendi per grucce
Chain for dress hangers
Crochet de suspension pour cintre
Cadena sube y baja para percuas



Cod.	Descrizione
------	-------------

U.1000

305x33mm

Pinza topper "diritta" acciaio inox
"Straight" topper clamp stainless steel
Pince topper "droite" acier inoxydable
Pinza topper "retta" acero inox



Cod.	Descrizione
------	-------------

U.1010

280x33mm

Pinza topper "curva" acciaio inox
"Curved" topper clamp stainless steel
Pince topper "coudee" acier inoxydable
Pinza topper "curva" acero inox



Cod.	Descrizione
------	-------------

U.1020

190x33mm

Pinza "chiudispacco" acciaio inox
"Vent" clamp stainless steel
Pince pour "fentes" acier inoxydable
Pinza "cierra aberturas" acero inox



Cod.

Descrizione

Pinza "chiudispacco larga" acciaio inox
"Large vent" clamp stainless steel
Pince "large pour fentes" acier inoxydable
Pinza "cierra aberturas" acero inox

U.1030

190x63mm



Pinza "chiudispacco" acciaio inox
"Vent" clamp stainless steel
Pince pour "fentes" acier inoxydable
Pinza "cierra aberturas" acero inox

U.1040

300x33mm



Molla ricambio per pinze acciaio inox
Spring for stainless steel clamp
Ressort de rechange pour pince acier inoxydable
Muelle de recambio para pinzas acero inox

U.1100



Gomma ricambio per pinze acciaio inox
Rubber for stainless steel clamp
Gomme de rechange pour pince en acier inoxydable
Goma de recambio para pinzas de acero inox

U.1110











Pièces différentes
Partes varias

C **PRIMA**

Cod.	Descrizione	
U.1200	Spazzola in velluto Velvet brush Brosse en velours Cepillo de terciopelo	
U.1210	Spazzola in velluto "double face" "Double face" velvet brush Brosse en velours "double face" Cepillo de terciopelo "double face"	
U.1300	Rullo adesivo con ricambio Adhesive roll with reloading Rouleau adhesif avec recharge Rollo de cinta adhesiva con recambio	
U.1310	Ricambio adesivo per rullo (2 pz) Reloading for adhesive roll (2 pcs) Recharge pour rouleau adhesif (2 pcs) Recambio para rollo de cinta adhesiva (2 pz)	









Cod. Descrizione

Nastro "FIBERTAG" spessore 12mm (12 pz)
 "FIBERTAG" tape thick. 12mm (12 pcs)
 Ruban "FIBERTAG" ép. 12mm (12 pcs)
 Cinta "FIBERTAG" espes. 12mm (12 pz)

- U.1400 
- U.1402 
- U.1404 
- U.1406 
- U.1408 
- U.1410 
- U.1412 
- U.1414 













Nastro "FIBERTAG" spessore 24mm (6 pz)
 "FIBERTAG" tape thick. 24mm (6 pcs)
 Ruban "FIBERTAG" ép. 24mm (6 pcs)
 Cinta "FIBERTAG" espes. 24mm (6 pz)

- U.1420 
- U.1422 
- U.1424 
- U.1426 
- U.1428 
- U.1430 
- U.1432 
- U.1434 



Carta numerata per marcatura giornaliera
 Prenumbered garment tags
 Papier pour le marquage journalier
 Numeros para marcaje de prendas

- U.1450 
- U.1452 
- U.1454 
- U.1456 
- U.1458 
- U.1460 
- U.1462 
- U.1464 
- U.1466 
- U.1468 



Cod. **Descrizione**

Piastra stiracarta
Paper ironing plate
Plaque pour repasser le papier
Placa plancha papel adhesivo

U.1500 760x145mm 1300 W.



Resistenza piastra stiracarta
Heater for paper ironing plate
Resistance plaque pour repasser le papier
Resistencia para placa plancha papel adhesivo

U.1510 650 W.

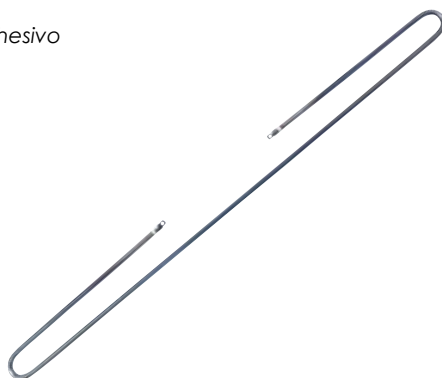

Termostato piastra stiracarta
Thermostat for paper ironing plate
Thermostat plaque pour repasser le papier
Termostato para placa plancha papel adhesivo

U.1520



Cod. **Descrizione**

Pinzatrice
Stapler
Agrafeuse
Grapadora

U.1600 "ACE"



Punti per pinzatrice
Staples
Agrafes
Grapas

U.1610 "ACE" (5000 pz)



Pinzatrice
Stapler
Agrafeuse
Grapadora

U.1800 "BOSTITCH" 6mm



Punti per pinzatrice
Staples
Agrafes
Grapas

U.1810 "BOSTITCH" 6mm (5000 pz)



Pièces différentes
Partes varias

C **PRIMA**

Cod.

Descrizione

Filtro bivalente
Powder filter disk
Disque filtre bivalent
Disco filtrante bivalente

U.2030 Ø 320mm foro Ø 40mm
U.2035 Ø 320mm foro Ø 42mm
U.2040 Ø 320mm foro Ø 45mm

U.2060 Ø 340mm foro Ø 40mm
U.2070 Ø 340mm foro Ø 42mm
U.2080 Ø 340mm foro Ø 45mm



Filtro ecologico
Ecological filter disk
Disque filtre ecologique
Disco filtrante ecologico

U.2230 Ø 320mm foro Ø 40mm
U.2235 Ø 320mm foro Ø 42mm
U.2240 Ø 320mm foro Ø 45mm

U.2260 Ø 340mm foro Ø 40mm
U.2270 Ø 340mm foro Ø 42mm
U.2280 Ø 340mm foro Ø 45mm



Sacco lavaggio a secco con corda
Dry cleaning bag with rope
Filet nettoyage à sec avec corde
Saco de limpiar a seco con cuerda

U.3000 700x500mm
U.3050 850x500mm
U.3100 900x600mm
U.3150 1300x900mm



Sacco lavaggio a secco con cerniera
Dry cleaning bag with zipper
Filet nettoyage a' sec avec fermeture éclair
Saco de limpiar a seco con cremallera

U.3500 700x500mm
U.3550 850x500mm
U.3600 900x600mm
U.3650 1300x900mm



Cod. Descrizione

Sacco lavaggio ad acqua con corda
Washing bag with rope
Filet de lavage avec corde
Saco de limpiar en agua con cuerda

U.4000	700x500mm
U.4050	850x500mm
U.4100	900x600mm
U.4150	1300x900mm



Sacco lavaggio ad acqua con cerniera
Washing bag with zipper
Filet de lavage avec fermeture éclair
Saco de limpiar en agua con cremallera

U.4500	700x500mm
U.4550	850x500mm
U.4600	900x600mm
U.4650	1300x900mm



Pièces différentes
Partes varias

C PRIMA

< PRIMA

Solerte corazzate in PTFE
Armored PTFE iron shoes

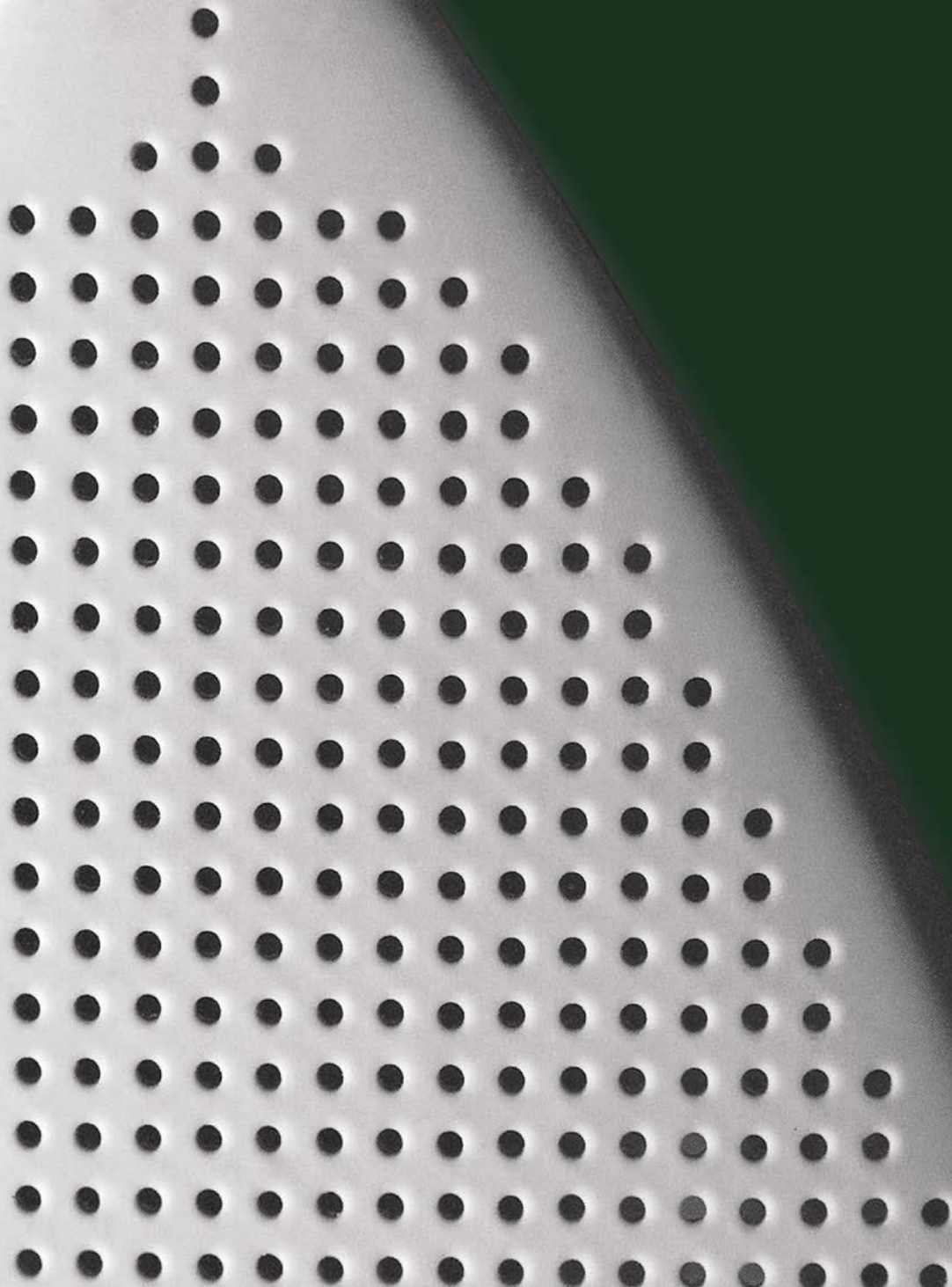

Cod.

Descrizione

Soletta corazzata in PTFE
 Armored PTFE iron shoe
 Semelle renforcées en PTFE
 Plantilla en PTFE y aluminio

V.0010	VERONESI PICCOLO	V.0362	CASOLI FV71
V.0015	IRON LEGER	V.0367	CASOLI FV75
V.0020	BISHOMATIC G.	V.0369	EC-11
V.0025	F2	V.0375	REVERBERI 29
V.0030	STIROVAP MOD.171	V.0380	SUPER MASTER
V.0035	VAPMATIC V	V.0385	IMPULSA 2040
V.0050	LEMM NUOVO 1	V.0400	VERONESI GRANDE
V.0055	MACPI 028	V.0405	SPIDIVAP
V.0060	VEIT 2128	V.0410	IRON LOURD
V.0065	VEIT 2119	V.0415	IRON BROOK
V.0070	SUSSMAN E 100	V.0425	OMEGA
V.0075	EC-2000/PA	V.0430	F1
V.0080	LK5	V.0432	STIROVAP MOD.170
V.0082	JET IRON	V.0450	GEMME
V.0084	L5 EUR	V.0455	LELIT
V.0086	H1ENEW	V.0460	REVERBERI 28
V.0088	H2ENEW	V.0465	EC-02
V.0090	CAMPTEL T5	V.0470	MACPI 074
V.0100	EUROSTAR 425	V.0475	DRYMASTER
V.0150	EUROFLEX	V.0500	TULIPANO
V.0200	SILTER STB-200	V.0515	DUBLO
V.0205	SILTER MAG-200	V.0520	JOLLY
V.0250	LANU	V.0525	SILTER STB-250
V.0255	ESSE 85	V.0530	MACPI 073
V.0300	TREVIL F02	V.0532	MASCHIO
V.0305	DOMINA	V.0535	PONY JUNIOR 2
V.0310	COVEMAT CV 90	V.0550	VEIT HD 2000
V.0315	TREVIL F07	V.0555	VEIT ELECTRONIC 2000
V.0320	TREVIL F020	V.0560	VEIT 2131
V.0350	IRONMASTER	V.0565	VEIT HD 2002
V.0355	DUE EFFE	V.0570	EC-289
V.0359	PROFESSOR	V.0600	PRIMA M.
V.0360	CASOLI	V.0650	KARKER BE 6000
V.0361	CASOLI AG-92	V.0700	PROFESS

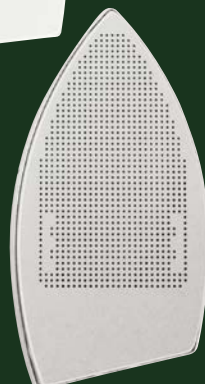
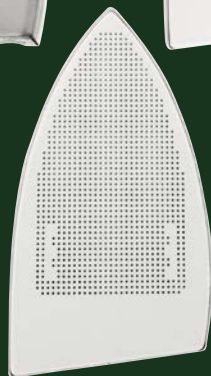
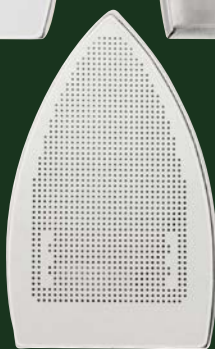

Cod.

Descrizione

Soletta corazzata in PTFE
Armored PTFE iron shoe
Semelle renforcee en PTFE
Plantilla en PTFE y aluminio

V.0750	SARTITALIA NUOVO	V.1250	SAXEL
V.0755	STAR PICCOLO	V.1300	NAOMOTO CDP 410
V.0760	CIEFFE PICCOLO	V.1305	NAOMOTO CDP 420
V.0765	COMEL 721 P	V.1350	CISSEL VECCHIO
V.0770	BIEFFE PICCOLO	V.1400	BISHOMATIC
V.0775	CIEFFE 03	V.1405	MACPI 026
V.0780	STIROVAP MOD.181	V.1410	CAMPTEL
V.0800	MAXI LEMM	V.1500	SARTITALIA VECCHIO
V.0850	MACPI 030	V.1505	VAPMATIC S
V.0855	MACPI 031	V.1600	NAOMOTO HLS 600
V.0860	MACPI 032	V.1650	PONY SENIOR
V.0865	MACPI 033	V.1700	GEMATIC AM
V.0870	MACPI 035	V.1705	GHIDINI R.
V.0875	MACPI 016	V.1800	NAOMOTO PICCOLO
V.0900	APRIPIEGA 2F	V.1805	OSAKA B.6
V.0905	MACPI 070	V.1810	TREVIL F021
V.0910	TREVIL F014	V.1815	TREVIL F022
V.0915	EC-7	V.1820	TREVIL F003
V.0920	APRICUCITURE FK	V.1825	TREVIL F004
V.0950	STAR GRANDE	V.1830	TREVIL F005
V.0955	CIEFFE GRANDE	V.1835	TREVIL F16
V.0960	COMEL 721 G	V.1840	TREVIL F316
V.0965	BIEFFE GRANDE	V.1850	PONY JUNIOR
V.0970	CIEFFE 04	V.1900	KRAPF HDP 1106
V.0975	STIROVAP MOD.180	V.1950	STIROVAP 2
V.1000	ARIETE	V.2000	MACPI 014
V.1050	MACPI 034	V.2050	FOGACCI
V.1100	STIROVAP 1	V.2100	BERNINA USA
V.1150	CISSEL NUOVO	V.2150	MIGNON H.
V.1155	CISSEL ACA 1000	V.2200	STIROVAP LD1
V.1160	CISSEL ACA 2000	V.2250	ROTTAG B.
V.1200	COMPACT P300	V.2300	L 103

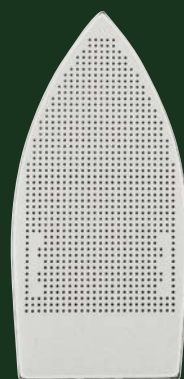
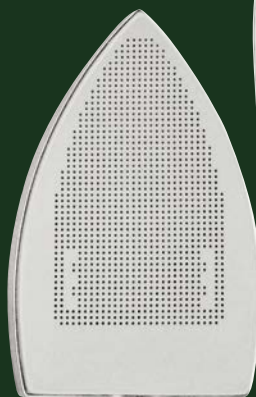
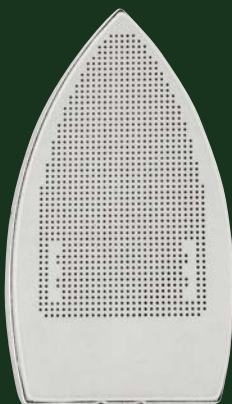
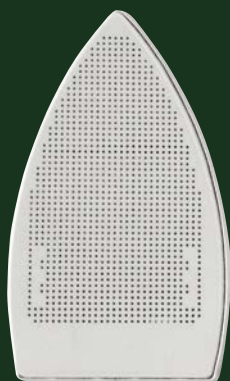

Cod.**Descrizione**

Soletta corazzata in PTFE
 Armored PTFE iron shoe
 Semelle renforcee en PTFE
 Plantilla en PTFE y aluminio

V.2350	SUSSMAN	V.3250	COVMAT
V.2360	AQUASTEAM	V.3300	MACPI 011
V.2400	EDM 2	V.3350	GHIDINI GRANDE
V.2450	STIROVAP 3	V.3355	PONY SENIOR 2
V.2500	STIROVAP CASA	V.3360	MAX STIR G
V.2550	MSP 410	V.3400	MACPI 007
V.2555	HSP 420	V.3450	ROTTAG DA
V.2560	SP-420	V.3455	ROTTAG D.
V.2565	TREVIL F318	V.3460	STIROLUX
V.2600	BISHOMATIC 333	V.3500	NORVA 2
V.2650	EVE	V.3550	LW 10 LUNGO
V.2705	OSAKA B.8	V.3600	CISSEL ALL STEAM
V.2800	MIGNON PRIMA	V.3650	GHIDINI PICCOLO
V.2850	VOMAT 8	V.3655	MAX STIR PICCOLO
V.2855	VEIT HN 2000	V.3700	IBER
V.2860	VEIT 2150	V.3750	MICRO MIGNON
V.2900	ALL STEAM 2F	V.3800	LANDRY 909 S
V.2950	DANOR	V.3850	LK NUOVO
V.3000	NORVA	V.3900	CAREZZA STIR
V.3005	NORVA 1	V.3950	B 8 TN
V.3010	NORVA 91	V.4000	MACPI 021
V.3050	PICCOLO H.	V.4050	QUATTRO EFFE
V.3100	MEDIO PRIMA	V.4100	SILVERSTAR PM 100
V.3150	GEMATIC NM	V.4105	ES 85 F

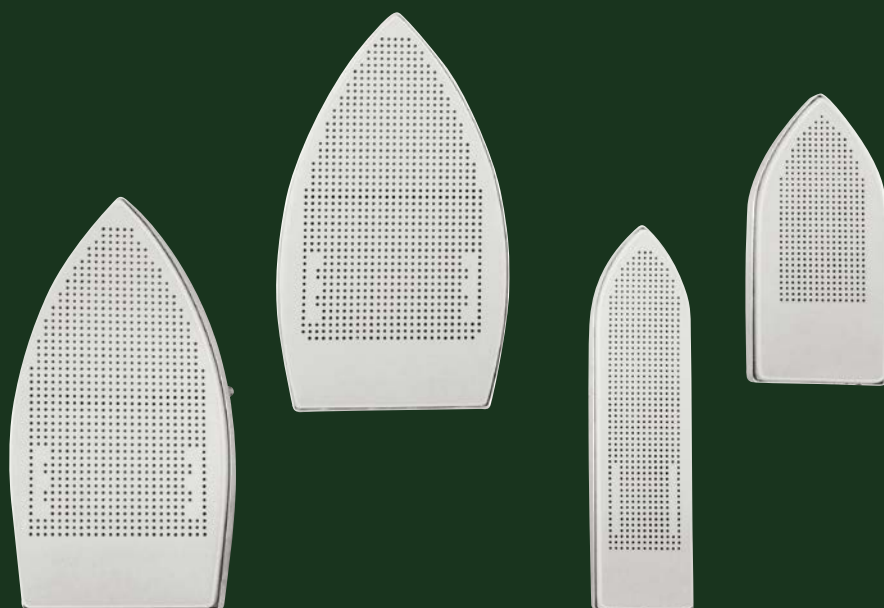

Semelles renforcées en PTFE
 Plantillas en PTFE y aluminio

< **PRIMA**

Cod.

Descrizione

Soletta corazzata in PTFE
Armored PTFE iron shoe
Semelle renforcee en PTFE
Plantilla en PTFE y aluminio

V.4150	KRAPF 1005	V.5000	TEST DDF
V.4155	VEIT 2117	V.5050	STIRELLA
V.4200	LW 10 CORTO	V.5100	LEMM 2
V.4250	REVERBERI 27	V.5150	TEST DDB LUNGO
V.4300	APEX PICCOLO	V.5200	LANDRY 912 H
V.4350	GICONMES	V.5250	APEX GRANDE
V.4400	HI TECH	V.5255	AFV2
V.4450	M 102	V.5300	TEST DDH
V.4500	MACPI 045	V.5350	LM NUOVO
V.4550	POLTI	V.5400	ES 85 AF
V.4600	BS 3P	V.5450	TEST DDB CORTO
V.4650	SPEEDY	V.5460	TEST DDB VECCHIO
V.4700	IMPULSA 2050	V.5500	STIROTECNICA
V.4750	KRAPF 1102	V.5505	STIROTECNICA 2000
V.4755	VEIT 1101	V.5510	APRIPIEGA LS7
V.4760	VEIT 2112	V.5550	SAXEL NUOVO
V.4765	VEIT DEWA	V.5600	NAOMOTO CNP 410
V.4850	LEMM	V.5655	LORD
V.4900	KRAPF 1104	V.5700	IMPULSA 2000
V.4950	SUSSMAN ELECT 100	V.5705	IMPULSA 2020

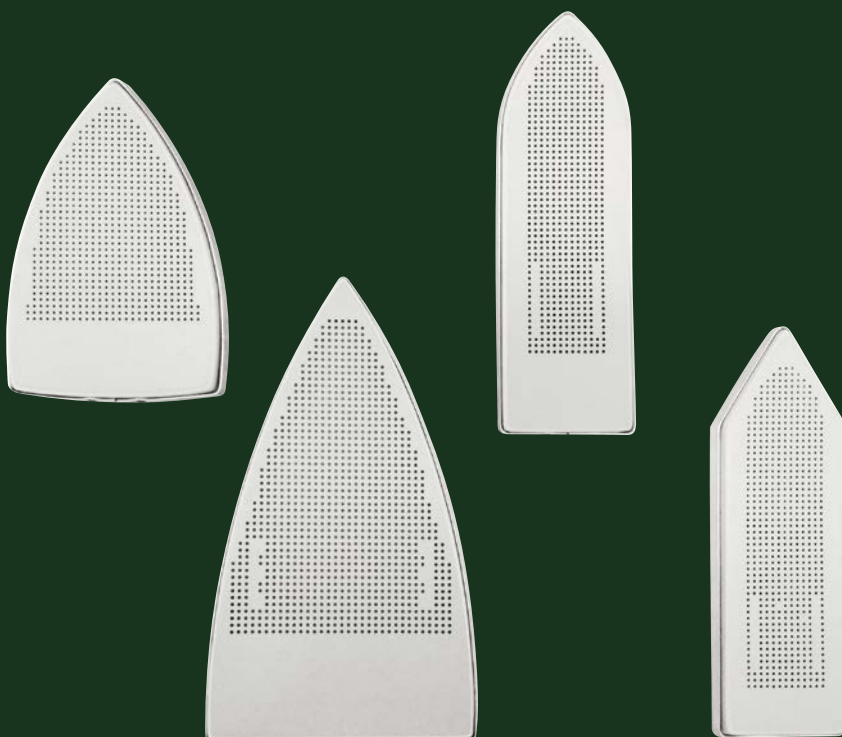

Cod.**Descrizione**

Soletta corazzata in PTFE
 Armored PTFE iron shoe
 Semelle renforcées en PTFE
 Plantilla en PTFE y aluminio

V.5850	VEIT DEWA 2112	V.7355	MACPI 080
V.5900	IBIS 600	V.7360	TREVIL F20
V.6000	STYLE 1	V.7365	TREVIL F320
V.6005	STYLE 70	V.7400	SIEL
V.6050	CIBI	V.7450	IMPEX
V.6100	PLAVOR	V.7500	VEIT HP 2003
V.6150	STYLE 3	V.7700	SWISS MATIC Typ B
V.6155	STYLE 100	V.7750	SWISS MATIC Typ BMS
V.6200	FAI GRANDE	V.7800	UNITEKNO
V.6250	FAI PICCOLO	V.7850	MB
V.6300	ROTTAG E.	V.7900	VEIT 2157
V.6350	VOMAT GRANDE	V.7950	NEVADA
V.6400	TEST 2-Z-1	V.7955	MB JOLLY
V.6450	TEST 2-Z-2	V.7960	OPEN ALL STAR 2F
V.6505	IBIS PICCOLO	V.8000	NAOMOTO HSP 320
V.6550	MACPI 006	V.8050	SINGER
V.6600	TEST DBB	V.8100	NAOMOTO SWN-8
V.6650	HACHEN MEDIO	V.8150	STIR MAXI
V.6750	IBIS	V.8200	APRIPIEGA 2F NEW
V.6800	IMPULSA 3P	V.8205	EC 7 OPEN
V.6850	SHELDON	V.8250	APRIPIEGA ALL STEAM 2F NEW
V.6900	MACPI 012 TURBO	V.8300	LQ
V.6950	LEMM NUOVO 2	V.8305	EOS
V.7000	EDAM 10	V.8310	EC 112 ST
V.7050	VEIT 2	V.8350	SPEEDY STIRANTE 2F
V.7100	IMPULSA S.	V.8400	PONY SENIOR TT
V.7150	SEAM BUSTER	V.8450	NOAMOTO AHS 400
V.7200	LM VECCHIO	V.8500	SP-320
V.7250	BOWE	V.8505	TREVIL F321
V.7300	TEST DBL	V.8550	NAOMOTO CDP 420 "L"
V.7350	APRIPIEGA ALL STEAM 2F	V.8600	VETT HS 2003



Guarnizione silicone adesivo per solette
 Adhesive silicon gasket for iron shoes
 Joint silicone adhesive pour semelles
 Guarnicion de silicona adhesiva para plantillas

V.9000



Semelles renforcées en PTFE
 Plantillas en PTFE y aluminio

< **PRIMA**

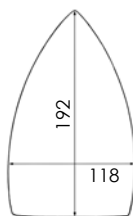

VERONESI PICCOLO
IRON LEGER
F2
STIROVAP MOD. 171
VAPMATIC V

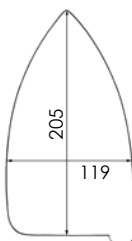

LEMM NUOVO 1
MACPI 028
VEIT 2128
SUSSMAN E 100
EC-2000/PA
LK5
L5 EUR
H1ENEW
H2ENEW

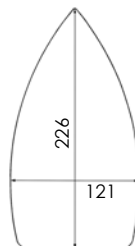

SILTER STB-200
SILTER MAG-200

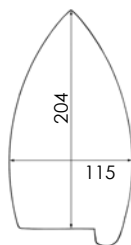

TREVIL F02
COVEMAT CV 90
TREVIL F07
TREVIL F020

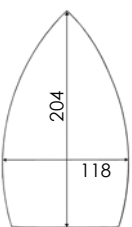

IRONMASTER
PROFESSOR
CASOLI
CASOLI AG-92
EC-11
REVERBERI 29

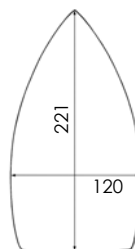

VERONESI GRANDE
IRON LOURD
F1
STIROVAP MOD. 170

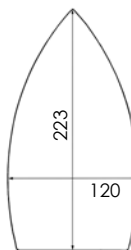

GEMME
LELIT
REVERBERI 28
EC-02
MACPI 074
DRYMASTER

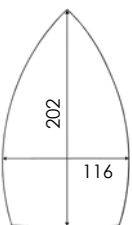

TULIPANO
JOLLY
SILTER STB-250
MACPI 073
PONY JUNIOR 2

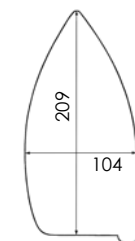

VEIT HD 2000
VEIT HD 2002

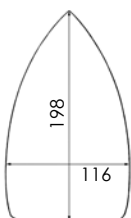

SARTITALIA NUOVO
STAR PICCOLO
CIEFFE PICCOLO
COMEL 721 P
BIEFFE P
CIEFFE 03
STIROVAP MOD. 181

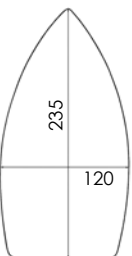

MAXI LEMM

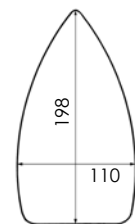

MACPI 030
MACPI 032
MACPI 033

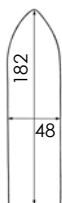

APRIPIEGA 2F
MACPI 070
TREVIL F014
EC-7
FK

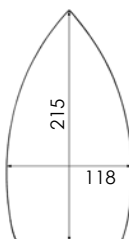

STAR GRANDE
CIEFFE GRANDE
COMEL 721 G
BIEFFE G
CIEFFE 04
STIROVAP MOD. 180

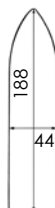

MACPI 034

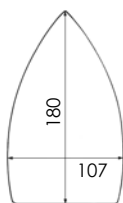

CISSEL NUOVO
CISSEL ACA 1000
CISSEL ACA 2000

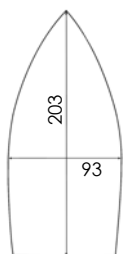

NAOMOTO CDP 410
NAOMOTO CDP 420

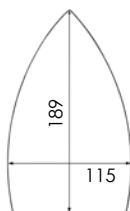

BISHOMATIC
MACPI 026

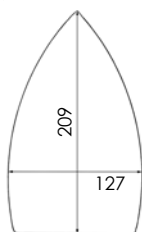

PONY SENIOR

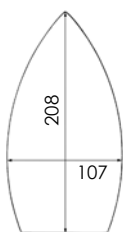

TREVIL F021
TREVIL F022
TREVIL F003
TREVIL F004
TREVIL F005
TREVIL F16
TREVIL F316

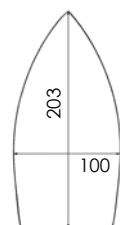

MSP 410
HSP 420
SP-420
TREVIL F318

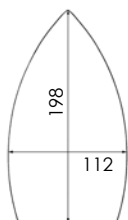

ALL STEAM 2F

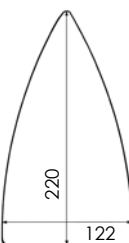

POLTI

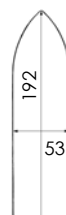

APRIPIEGA ALL STEAM 2F
MACPI 080
TREVIL F20
TREVIL F320

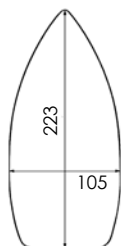

VEIT HP 2003

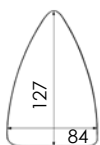

VEIT 2157



NAOMOTO HSP 320

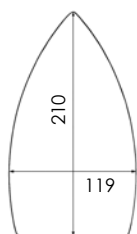

STIR MAXI

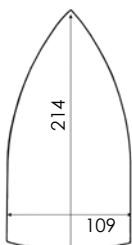

EUROFLEX

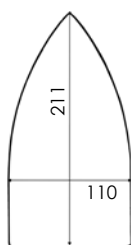

ESSE 85
LANU

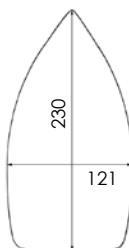

MB

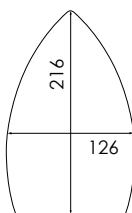

NEVADA
MB JOLLY
OPEN ALL STAR 2F

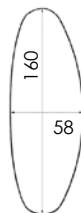

NAOMOTO SWN 8

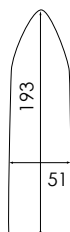

APRIPIEGA 2F NEW
EC 7 OPEN

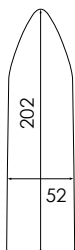

APRIPIEGA ALL STEAM
2F NEW

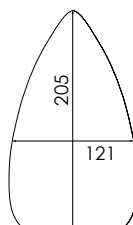

LQ
EOS



SPEEDY STIRANTE

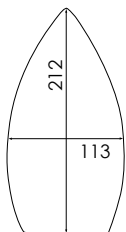

PONY SENIOR TT

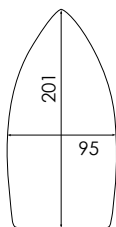

NAOMOTO AHS 400

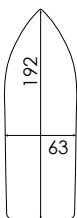

SP 320
TREVIL F321

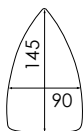

MACPI 045

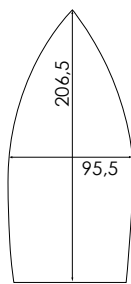

NAOMOTO CDP 420 "L"

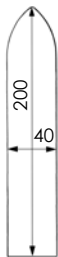

VETT HS 2003

Cod.

Descrizione

Soletta semplice in PTFE
PTFE iron shoe
Semelle simple en PTFE
Plantilla en PTFE sencilla

Z.0010	MAXI LEMM	Z.0375	TREVIL F16
Z.0100	VERONESI GRANDE	Z.0380	TREVIL F316
Z.0110	STAR GRANDE	Z.0400	IRONMASTER
Z.0120	CIEFFE GRANDE	Z.0410	DUE EFFE
Z.0130	AMA UNIVERSAL	Z.0420	CASOLI
Z.0140	SPIDIVAP	Z.0430	MACPI 073
Z.0150	OMEGA	Z.0440	SILC
Z.0160	AEG	Z.0450	BM
Z.0170	IRON BROOK	Z.0470	TULIPANO
Z.0180	IRON LOURD	Z.0480	EVE
Z.0190	REVERBERI 28	Z.0490	EVM HACHEN
Z.0200	L'ELIT	Z.0500	JOLLY
Z.0210	GEMME	Z.0510	SUPERMASTER
Z.0220	F1	Z.0520	REVERBERI 29
Z.0230	COMEL 721 G	Z.0530	SUPREMA
Z.0235	SILTER STB-200	Z.0540	ALL STEAM 2F
Z.0240	SILTER MAG-200	Z.0550	PONY JUNIOR 2
Z.0245	STIROVAP MOD.170	Z.0555	CASOLI AG-92
Z.0250	EC-02	Z.0560	EC-11
Z.0255	STIROVAP MOD.180	Z.0600	LEMM NUOVO 1
Z.0260	MACPI 074	Z.0605	EC-2000/PA
Z.0270	DRYMASTER	Z.0610	MACPI 028
Z.0300	VEIT HD 2000	Z.0615	LK5
Z.0310	VEIT 2131	Z.0620	VEIT 2119
Z.0320	VEIT 2132	Z.0625	L5 EUR
Z.0330	VEIT ELECTRONIC 2000	Z.0630	SUSSMAN E 100
Z.0345	TREVIL F022	Z.0635	H1ENEW
Z.0350	VEIT HD 2002	Z.0640	VEIT 2128
Z.0355	TREVIL F003	Z.0645	H2ENEW
Z.0360	EC-289	Z.0650	NEW STYLE
Z.0365	TREVIL F004	Z.0660	BIELLE
Z.0370	TREVIL F005	Z.0700	SARTITALIA
		Z.0710	STIROVAP 2



Cod.**Descrizione**

Soletta semplice in PTFE
 PTFE iron shoe
 Semelle simple en PTFE
 Plantilla en PTFE sencilla

Z.0720	DANOR	Z.1110	SUSSMAN P. 100771
Z.0730	VAPMATIC S	Z.1200	PRIMA M.
Z.0740	CIEFFE PICCOLO	Z.1210	NAOMOTO CNP 410
Z.0750	STAR PICCOLO	Z.1220	NAOMOTO CDP 420
Z.0800	VERONESI PICCOLO	Z.1300	KRAPF HDP 1106
Z.0805	STIROVAP MOD.171	Z.1400	VEIT 024
Z.0810	BISHOMATIC	Z.1410	VEIT HN 2000
Z.0815	VAPMATIC V	Z.1420	VOMAT 8
Z.0820	MACPI 026	Z.1430	VEIT 2150
Z.0830	PONY JUNIOR	Z.1440	VEIT 2151
Z.0840	CAMPTEL	Z.1500	GICONMES
Z.0860	IRON LEGER	Z.1510	CIBI
Z.0870	REVERBERI 27	Z.1600	TREVIL F02
Z.0890	MAX STIR	Z.1610	DOMINA
Z.0900	F2	Z.1620	TREVIL F07
Z.0910	COMEL 721 P	Z.1630	TREVIL F020
Z.0920	STIROVAP MOD.181	Z.1700	NORVA
Z.1000	MACPI 030	Z.1710	VEIT HP 2003
Z.1010	MACPI 031	Z.1800	LW 10 LUNGO
Z.1020	MACPI 032	Z.1810	LW 10 CORTO
Z.1030	MACPI 033	Z.1820	APRICUCITURE ALL STEAM 2F
Z.1040	MACPI 035	Z.1830	MACPI 034
Z.1050	MACPI 016	Z.1840	TREVIL F20
Z.1060	NAOMOTO HSP 420	Z.1850	TREVIL F320
Z.1070	SP-420	Z.1900	KRAPF 1102
Z.1075	MSP 410	Z.1920	VEIT 2112
Z.1080	HSP 420	Z.1930	DEWA
Z.1085	TREVIL F318	Z.2000	EDM2
Z.1100	CISSEL	Z.2010	BISHOMATIC 333

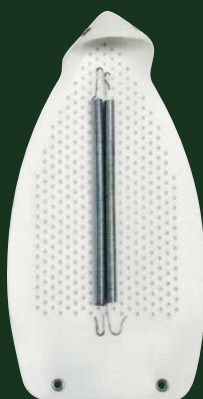

Semelles simples en PTFE
 Plantillas en PTFE sencillas

Z PRIMA

Cod.

Descrizione

Soletta semplice in PTFE
PTFE iron shoe
Semelle simple en PTFE
Plantilla en PTFE sencilla

Z.2100	TEST DDH	Z.2600	VEIT 2117
Z.2110	MIGNON PRIMA	Z.2610	KRAPF 1005
Z.2120	MIGNON H.	Z.2620	EUROSTAR 425
Z.2130	APRIPIEGA 2F	Z.2700	NAOMOTO PICCOLO
Z.2140	MACPI 070	Z.2710	OSAKA B6
Z.2150	MACPI 014	Z.2800	SUSSMAN
Z.2160	TREVIL F014	Z.2820	AQUASTEAM
Z.2170	EC-7	Z.2830	ROTTAG S.V.
Z.2200	GHIDINI	Z.2900	PICCOLO H.
Z.2210	PONY SENIOR	Z.3000	IMPULSA 3P
Z.2220	STIROVAP 3	Z.3100	REIMERS PICCOLO
Z.2230	SUSSMAN ELECT 100	Z.3110	NAOMOTO HSP 320
Z.2300	TEST DDB LUNGO	Z.3200	REIMERS GRANDE
Z.2310	TEST DDB CORTO	Z.3500	PM 100
Z.2400	STIROVAP 1	Z.3600	HLS 610 "BIG SIZE" (perla)
Z.2500	LEMM	Z.3700	NI 1600P "SMALL SIZE" (japan)



Soletta PTFE per ferri casalinghi
PTFE iron shoe for home irons
Semelle PTFE pour fers menager
Plantilla en PTFE para planchas de mano de casa

Z.5000	0,3mm
Z.6000	0,5mm



I - ORDINE - FORMAZIONE DEL CONTRATTO

Tutti gli ordini comportano l'accettazione senza riserve da parte del cliente delle presenti condizioni generali di vendita che prevarranno su qualsiasi clausola contraria che possa essere evidenziata nei moduli d'ordine del cliente, nelle sue condizioni generali d'acquisto od in qualsiasi altro documento da lui emesso, salvo deroghe previamente accettate da PRIMA SRL e notificate per iscritto al cliente.

II - SPEDIZIONE DEI PRODOTTI

I prodotti vengono venduti in porto assegnato o porto franco con addebito. Di conseguenza, la consegna viene considerata effettiva e i rischi sono trasferiti al cliente a partire dal momento in cui i prodotti vengono spediti. E' quindi competenza di quest'ultimo o del destinatario, rivalersi nei confronti dei trasportatori e degli assicuratori dal momento in cui i prodotti vengono consegnati con ammanchi, danneggiati etc.

III - TEMPI DI CONSEGNA - QUANTITÀ CONSEGNATE

I termini di consegna indicati sulle conferme d'ordine sono riportati a titolo indicativo e non potranno, in nessun caso, costituire da parte di PRIMA SRL l'obbligo irrevocabile di consegnare entro la data fissata.

Pertanto, non sarà possibile rivalersi contro PRIMA SRL per il ritardo nella consegna e nessun ordine potrà essere annullato su questa base. Il ritardo di PRIMA SRL non darà diritto al risarcimento dei danni in caso di controversie tra il cliente di PRIMA SRL ed i suoi clienti. PRIMA si riserva, inoltre, il diritto di non consegnare o di consegnare solamente una parte dei prodotti ordinati in caso di forza maggiore, conformemente a quanto previsto alla clausola IX.

IV - PREZZI

Salvo accordi particolari tra PRIMA SRL ed il suo cliente, i prezzi sono da considerarsi al netto di qualsiasi onere, quali spese d'imballo, spese di trasporto e di assicurazione, diritti doganali, imposte, oneri fiscali e tributari, in particolare IVA, di qualsiasi natura essi siano.

Salvo indicazioni contrarie, i prezzi delle offerte di PRIMA SRL sono fissi. Tuttavia, PRIMA SRL si riserva il diritto di rivedere tali prezzi in base alle fluttuazioni economiche e monetarie che possono verificarsi tra l'acquisizione dell'ordine e la sua evasione e che comportano variazioni negli elementi determinanti i suddetti prezzi.

I prezzi indicati da PRIMA SRL nelle sue offerte e nelle conferme d'ordine si riferiscono alle quantità ordinate e PRIMA SRL si riserva il diritto di modificare i prezzi unitari in caso di modifica delle quantità.

Salvo accordi diversi, tali offerte hanno validità di un mese a decorrere dalla data di emissione.

V - CONDIZIONI DI PAGAMENTO - RITARDO NEL PAGAMENTO O MANCATO PAGAMENTO

Salvo diverse indicazioni nelle conferme d'ordine o nelle fatture emesse da PRIMA SRL, tutte le fatture devono essere saldate a Pazzolo sull'Oglio, al netto senza sconto.

Eventuali reclami relativi ad una qualsiasi fornitura non esonerano il cliente dal pagamento delle fatture entro la loro scadenza.

In caso di ritardo di pagamento resta il diritto di applicare gli interessi previsti dalle disposizioni legali.

Il mancato pagamento di una sola scadenza conformemente ai termini e alle condizioni pattuiti, comporterà con effetto immediato e di diritto, la decadenza di tutte le scadenze di pagamento in corso e renderà, di conseguenza, esigibile la totalità delle somme ancora dovute dal cliente, con l'applicazione delle penali di ritardo conformemente alle condizioni previste nella presente clausola, senza necessità d'ingiunzione.

Il mancato pagamento di una sola scadenza nelle condizioni e termini stabiliti, autorizza PRIMA SRL a sospendere le consegne e ad annullare la totalità o parte dell'ordine o degli ordini.

VI - CLAUSOLA DI RISERVA DI PROPRIETÀ

PRIMA SRL si riserva la proprietà dei prodotti consegnati ai suoi clienti fino all'effettivo pagamento della totalità del prezzo convenuto, costituito dalla somma principale e dagli oneri accessori.

In caso di mancato pagamento totale o parziale del prezzo pattuito entro il termine previsto per qualsiasi motivo, PRIMA SRL ha facoltà, senza procedure formali, di riprendere fisicamente possesso dei prodotti a spese, rischio e pericolo del cliente. In tal caso, il cliente s'impegna in particolare modo, a partecipare attivamente alla redazione di un inventario dei suddetti prodotti.

Il cliente si impegna ad informare i propri partner della presente clausola di riserva di proprietà.

PRIMA SRL potrà riprendere possesso dei prodotti non pagati detenuti da terzi acquirenti o esigere da questi ultimi il pagamento diretto del loro prezzo. Qualora i prodotti siano stati ceduti a terzi in buona fede, il diritto di rivendicazione di PRIMA SRL verterà primariamente sul prezzo incassato dal proprio cliente. In caso di incorporazione dei prodotti, il diritto di PRIMA SRL sarà esercitato, in proporzione al loro valore, sul prodotto in cui essi sono stati incorporati, sia nei confronti del cliente che nei confronti del terzo acquirente.

In ogni caso, i prodotti non potranno essere pignorati o dati in pegno, e la loro proprietà non potrà essere trasferita a terzi a titolo di

garanzia.

Le disposizioni precedenti non impediscono il trasferimento dei rischi al cliente a partire dalla consegna del prodotto.

Il cliente s'impegna ad adottare tutte le misure necessarie per la custodia e la conservazione dei prodotti e in particolare a sottoscrivere un'adeguata copertura assicurativa, senza che ciò costituisca una limitazione di responsabilità di nessun tipo.

In caso di vendita internazionale, ove necessario, il cliente dovrà espletare a sue spese, tutte le formalità richieste nel paese di destinazione dei prodotti per l'applicazione della presente clausola di riserva di proprietà.

VII - DESCRIZIONE E SPECIFICHE

La descrizione dei prodotti riportata nei cataloghi, listini e brochure rappresenta soltanto la generalità dei prodotti.

PRIMA SRL si riserva il diritto di modificare i prodotti senza preavviso.

VIII - RICORSI ALLA GARANZIA

I prodotti sono garantiti esenti da difetti di fabbricazione o di materiale, che li rendano non idonei ad un normale utilizzo. La garanzia è strettamente limitata al rimborso o alla sostituzione dei prodotti riconosciuti difettosi, in conformità alle seguenti condizioni.

- I reclami relativi alle quantità, al peso, alle dimensioni ed ai difetti visibili devono essere effettuati entro 8 giorni in caso di vendita nazionale o di 3 mesi in caso di vendita internazionale, a decorrere dalla data di consegna dei prodotti al cliente, effettuati a suo nome o per suo conto.

- PRIMA SRL garantisce i prodotti consegnati da qualsiasi difetto di fabbricazione o da difetti materiali, compresi i difetti non visibili, che li rendono non idonei ad un normale utilizzo, per una durata di 6 mesi in caso di vendite nazionali o di 12 mesi in caso di vendite internazionali, a decorrere dalla loro data di consegna, conformemente alla clausola II di cui sopra, purché i prodotti non abbiano subito modifiche od alterazioni prima o durante il loro utilizzo da parte del cliente. La sostituzione gratuita o il rimborso possono essere accordati soltanto dopo verifica da parte di PRIMA SRL dei prodotti interessati, che dovranno essere inviati franco trasporto e imballo. Le spese ed i rischi legati alla resa dei prodotti di cui si chiede la sostituzione od il rimborso, sono a carico del cliente.

Deterioramenti o difetti provocati da una normale usura, da incidenti o dall'utilizzo inappropriato del prodotto (in particolare manutenzione inadeguata, lubrificazione non corretta, sovraccarichi, montaggio errato, ecc.) non sono inclusi nella garanzia. I prodotti riconosciuti difettosi da PRIMA SRL saranno, a discrezione di PRIMA SRL, sostituiti o rimborsati al loro prezzo di fatturazione, per la totalità o parte del prodotto.

PRIMA SRL non sarà in alcun caso responsabile del danno per il mancato guadagno o di altri danni diretti od indiretti.

IX - FORZA MAGGIORE

PRIMA SRL non è responsabile in caso di mancata esecuzione di uno qualsiasi dei suoi obblighi, che sarebbe imputabile ad un caso di forza maggiore, come, a titolo esemplificativo e non esaustivo: catastrofi naturali, tempeste, inondazioni, gelo, incendio, difficoltà di approvvigionamento, sciopero o altri conflitti lavorativi, malfunzionamento o interruzione dei mezzi o delle vie di comunicazione, regolamentazioni governative che proibiscono la convertibilità o il trasferimento di valuta, l'importazione, l'esportazione o la vendita di prodotti, o qualsiasi ritardo legato ad esigenze concernenti la sicurezza del carico o al conseguimento delle autorizzazioni amministrative richieste nei termini prescritti.

X - ATTREZZATURE, STAMPI, SPECIFICITÀ, PROTOTIPI

La partecipazione ai costi di produzione dell'attrezzatura (utensili, stampi, ecc.) che potrebbe essere richiesta al cliente, non comporta il trasferimento a suo vantaggio della proprietà fisica di tali attrezzature o dei relativi diritti di proprietà intellettuale, salvo diversi accordi.

XI - CONTROVERSIE

PRIMA SRL e i clienti cercheranno di risolvere la loro controversia in via consensuale.

Qualora una conciliazione amichevole non fosse possibile, le controversie nate dall'interpretazione o dall'esecuzione delle presenti condizioni generali di vendita e di servizi, e/o dagli ordini, indipendentemente dalla motivazione, anche in caso di domanda incidentale o di pluralità di convenuti, saranno disciplinati esclusivamente dal diritto italiano e rientreranno nella competenza esclusiva del foro di BRESCIA, Italia

Le disposizioni precedenti sono applicabili alle vendite internazionali.

XII - DIVISIBILITÀ

Qualora una delle disposizioni del presente documento sia considerata come illegale, nulla o inapplicabile in virtù di una legge, di un regolamento o di una decisione giuridica, soltanto tale disposizione sarà considerata non valida, senza che ciò abbia delle conseguenze per le altre disposizioni del presente documento che rimarranno pienamente in vigore.

I - ORDERS - FORMATION OF THE CONTRACT

Any order implies strict adherence by the customer to these general conditions of sale which shall prevail notwithstanding anything inconsistent therewith or contrary thereto in customer's order, customer's general purchasing conditions or any other document issued by customer unless otherwise previously agreed by PRIMA SRL of which the customer has been notified in writing.

II - DISPATCH OF PRODUCTS

The products are sold from PRIMA SRL ex works basis or with transport costs debited on invoice. Consequently, the delivery is deemed to be effective and the transfer of risks to the customer occurs when the products are loaded into the means of transportation made available the customer.

It is therefore the responsibility of the customer or recipient to take any action against the transporters and the insurers from the moment they receive the products under the above conditions and also in case of damages or missing goods or any other claims.

III - DELIVERY DATES - QUANTITIES DELIVERED

Delivery dates quoted on order acknowledgements are given as an indication only and are in no way a firm commitment on the part of PRIMA SRL to deliver by a certain date.

Consequently, no recourse may be brought against PRIMA SRL due to late delivery and no order may be cancelled due to the same. Late delivery may neither allow to claim damages against PRIMA SRL due to disputes arising between the customer and its own customers.

Moreover, PRIMA SRL reserves the right not to deliver or to deliver only a part of the products ordered if forced to do so by virtue of force majeure as defined in clause IX.

IV - PRICE

Except when specifically agreed by PRIMA SRL and the customer, prices exclude all types of expenses and costs, such as packaging costs, transport and insurance costs, customs duties, taxes and fiscal and fiscal-related charges, in particular V.A.T.

Unless otherwise stipulated, the prices in PRIMA SRL proposals are firm. However, unless specifically agreed by PRIMA SRL in writing, these prices may be reviewed due to economic and monetary fluctuations occurring between the placing of the order and its despatch, leading to variations in the elements which determine such prices.

The prices quoted and acknowledged by PRIMA SRL are valid for the quantity ordered, and should the quantity be altered, PRIMA SRL reserves the right to modify the unit prices accordingly.

Unless otherwise agreed, these proposals are valid for a one-month period as of their offering.

V - CONDITIONS OF PAYMENT - DELAY IN PAYMENT OR DEFAULT

Except when otherwise stipulated in acknowledgment of receipt or invoices of PRIMA SRL, all invoices are payable net without discount to Palazzolo sull'Oglio.

Any complaints concerning a supply do not entitle the customer to withhold any payment when due. Any delay in payment shall give rise automatically and without formal notice, to the payment of interest at the rate of the relevant legal provisions. Default of payment within the prescribed time and terms will immediately lead to the lawful termination of the remaining terms, and will, consequently, demand total payment of the outstanding debt without written notice or recourse to law, with the application of delay penalties in the terms specified above. Default of payment within the agreed terms and time authorizes PRIMA SRL to stop further deliveries and cancel all or part of the order(s).

VI - PROPERTY RESERVE CLAUSE

PRIMA SRL reserves the property of products delivered to its customers until effective payment of their whole price in principal and accessories.

In case of total or partial non-payment of the price when due, whatever the cause,

PRIMA SRL reserves the right to resume physical possession of the products without notice at the customer's expense and risks. In this case, the customer undertakes, in particular, to actively participate to the establishment of an inventory of the products.

The customer undertakes to inform its business partners of the existence of the present property reserve clause. PRIMA SRL can resume the unpaid products in the hands of every third party buyer or require from them the direct payment of their price. In the hypothesis where products would have been sold to a bona fide third party, the right of claiming of PRIMA SRL will apply first and foremost to the price received by its customer. In case of incorporation of products, the right of PRIMA SRL will apply, in proportion to their value, on the product into which they are incorporated, either toward the customer, or toward the third party buyer.

Notwithstanding any provision to the contrary, the products shall not be seized, pledged or their property shall not be transferred to a third party as a guarantee.

The previous provisions are without prejudice to the transfer of the risks to the customer as of the delivery of products. The customer undertakes to take all measures deemed suitable to preserve the products under its care, custody and control and in particular to take out adequate insurance cover, it being agreed that this latter could in no way imply any limitation of liability of the customer.

In case of export sale, the customer will have to, if necessary, carry out at his expenses, any formality which would be required, in the country of the products' delivery, for the enforcement of the present property reserve clause.

VII - DESCRIPTION AND SPECIFICATION

Descriptions in catalogues, price lists and publicity brochures only present the general nature of the products.

PRIMA SRL reserves the right to modify the products without prior notice.

VIII - WARRANTY

Products are warranted to be free from manufacturing and material defects that render them unfit for their normal use. The warranty is strictly limited to reimbursement or replacement of products accepted as defective under the following conditions:

• Claims concerning quantity, weight, dimensions or visible defects may be received within 8 days for national sales or 3 months in case of export sales, as of receipt by the customer or on its behalf.

• PRIMA SRL warrants the delivered products against all non-visible manufacturing and material defects, including all hidden defects that render them unfit for their normal use, for a period of 6 months for national sales or 12 months for international sales, from their delivery date in compliance with clause II above, provided that the products have not been modified or altered before or during their use by the customer.

The free replacement or the reimbursement can be granted only after examination, by PRIMA SRL, of the products concerned, which shall be sent to it carriage and packing paid. Expenses and risks of return will be chargeable to the customer.

Any deterioration or defect resulting from normal wear and tear, accident or misuse (in particular defective maintenance, unfit lubricant, overload, improper assembly, etc.) is excluded from the warranty.

Products accepted as defective by PRIMA SRL, will, at PRIMA SRL choice, either be replaced, or the invoice value reimbursed, in part or in total.

PRIMA SRL will under no circumstances be liable or responsible for any loss of profit or other direct or indirect damages.

IX - FORCE MAJEURE

PRIMA SRL shall not be liable for any failure to perform any of its obligations where such failure is a result of a Force Majeure event, in particular but not limited to: natural disasters, storms, floods, frost, fires, supply difficulties, strikes or other labour conflict, communication or traffic channels dysfunction or interruption, regulations of government authorities prohibiting the convertibility or transfer of foreign currencies, the import, export or sale of the products or any delay in connection with cargo security requirements or with obtaining the necessary administrative authorizations in due time.

X - TOOLS, MOULDS, SPECIFIC EQUIPMENTS, PROTOTYPES

Contribution to the costs of making the tooling (tools, moulds, etc.) which could be asked to the customer does not imply any transfer to its benefits of the physical property of such tooling nor of any intellectual property rights thereon, unless otherwise agreed.

XI - LEGAL DISPUTES

PRIMA SRL and the customer shall seek to amicably settle their dispute.

In case of failure to find an amicable settlement, any dispute arising from the interpretation of or action according to these general conditions of sale and services, and/or any order, even in the case of incidental request or involving several parties, shall be governed by and construed in accordance with the Italian law and shall be exclusively subject to the jurisdiction of the Brescia, Italy.

The previous provisions are applicable to the international sales.

XII - DIVISIBILITY

If any provision of the present general conditions is or becomes invalid, illegal or unenforceable in any respect, such invalidity, illegality or unenforceability shall not affect the enforceability of the remaining provisions of the present general conditions which will stay completely in force.

I - COMMANDE - FORMATION DU CONTRAT

Toute commande emporte acceptation sans réserve par le client des présentes conditions générales de vente qui prévaudront sur toutes stipulations contraires pouvant figurer sur les bons de commande du client, ses conditions générales d'achat ou tout autre document émanant de lui, sauf dérogations préalablement acceptées par PRIMA SRL et notifiées par écrit au client.

II - EXPÉDITION DES PRODUITS

Les produits sont vendus départ notre usine ou port franco avec débit frais de transport. En conséquence, la livraison est réputée effective et les risques sont transférés au client dès l'instant où les produits sont déposés dans le moyen de transport. Il appartient en conséquence à ce dernier, ou au destinataire, d'exercer tous recours contre les transporteurs et les assureurs dès l'instant où les produits sont livrés avec des dommages ou des pénuries de produits.

III - DÉLAIS DE LIVRAISON - QUANTITÉS LIVRÉES

Les délais de livraison mentionnés sur les accusés de réception de commandes sont donnés à titre indicatif et ne pourront, en aucun cas, constituer de la part de PRIMA SRL un engagement ferme de livrer à la date fixe. En conséquence, aucun recours ne pourra être exercé contre PRIMA SRL du fait de son retard dans la livraison et aucune commande ne pourra être annulée sur ce fondement. Le retard de PRIMA SRL ne saurait, non plus, ouvrir droit à des dommages-intérêts à l'occasion de différends survenant entre le client et ses propres clients.

PRIMA SRL se réserve, en outre, le droit de ne pas livrer ou de livrer seulement une partie des produits commandés, en cas de force majeure telle que définie à la clause IX.

IV - PRIX

Sauf convention particulière expresse entre PRIMA SRL et son client, les prix sont nets de tous frais et charges quelconques, tels que frais d'emballage, frais de transport et d'assurance, droits de douane, taxes, charges fiscales et parafiscales, et notamment T.V.A., de quelle nature qu'ils soient.

Sauf indication contraire, les prix des offres de PRIMA SRL sont fermes. Toutefois, PRIMA SRL se réserve le droit de réviser ces prix en raison des fluctuations économiques et monétaires qui peuvent se produire entre la passation de la commande et son exécution et qui entraînent des variations diverses dans les éléments de détermination de ces prix.

Les prix donnés par PRIMA SRL dans ses propositions et accusés de réception s'entendent pour les quantités commandées et PRIMA SRL se réserve le droit de modifier les prix unitaires en cas de modification de ces quantités.

Sauf convention contraire, ces offres sont valables pendant un mois à compter de leurs émissions.

V - CONDITIONS DE PAIEMENT - RETARD OU DÉFAUT DE PAIEMENT

Sauf stipulation contraire dans les accusés de réception ou factures de PRIMA SRL, toutes les factures sont payables à Palazzolo sull'Oglio, net sans escompte.

Les réclamations éventuelles concernant une fourniture quelconque ne dispensent pas le client de régler les factures à leur échéance. Tout retard de paiement donnera lieu de plein droit à l'application d'intérêts moratoires prévu par les dispositions légales.

Le défaut de paiement d'une seule échéance dans les délais et conditions convenus entraînera immédiatement et de plein droit la déchéance de toutes les échéances restant éventuellement à courir et rendra, en conséquence, exigible l'intégralité des sommes restant dues par le client, avec application des pénalités de retard dans les conditions prévues ci-dessus, sans qu'il soit besoin de mise en demeure.

Le défaut de paiement d'une seule échéance dans les conditions et délais convenus autorise PRIMA SRL à interrompre les livraisons et à annuler tout ou partie de la (des) commande(s).

VI - CLAUSE DE RÉSERVE DE PROPRIÉTÉ

PRIMA SRL se réserve la propriété des produits livrés à ses clients jusqu'au paiement effectif de l'intégralité de leur prix en principal et accessoires.

En cas de non-paiement total ou partiel du prix à l'échéance pour quelque cause que ce soit PRIMA SRL aura la faculté, sans formalités, de reprendre matériellement possession des produits aux frais, risques et périls du client. Dans ce cas, le client s'engage notamment à participer activement à l'établissement d'un inventaire desdits produits.

Le client s'engage à informer ses partenaires de l'existence de la présente clause de réserve de propriété.

PRIMA SRL pourra reprendre les produits impayés entre les mains de tous tiers acquéreurs ou exiger de ceux-ci le paiement direct de leur prix. Dans l'hypothèse où les produits auraient été cédés à un tiers de bonne foi, le droit de revendication de PRIMA SRL portera en priorité sur le prix encaissé par son client. En cas d'incorporation des produits, le droit de PRIMA SRL s'exercera, au prorata de leur valeur,

sur le produit dans lequel ils sont incorporés, soit envers le client, soit envers le tiers acquéreur.

En tout état de cause, les produits ne pourront être saisis, gagés et leur propriété ne pourra être transférée à un tiers à titre de garantie. Les dispositions précédentes ne font pas obstacle au transfert des risques au client dès la livraison des produits.

Le client s'engage à apporter tous ses soins à la garde et à la conservation des produits et notamment à souscrire toute couverture d'assurance adéquate, sans que cela constitue une quelconque limitation de responsabilité.

En cas de vente internationale, le client devra, le cas échéant, accomplir à ses frais, toute formalité qui serait requise, dans le pays de destination des produits, pour la mise en œuvre de la présente clause de réserve de propriété.

VII - DESCRIPTION ET SPÉCIFICATION

La description des produits et des services figurant dans les catalogues, tarifs, brochures ne présente que la nature générale des produits décrits. PRIMA SRL se réserve le droit de modifier les produits sans préavis.

VIII - RECOURS EN GARANTIE

Les produits sont garantis exempts de tout vice de fabrication ou défaut matière les rendant impropres à un usage normal. La garantie est strictement limitée au remboursement ou au remplacement des produits reconnus défectueux dans les conditions suivantes :

- Les réclamations concernant les quantités, poids, dimensions et vices apparents sont recevables dans le délai de 8 jours en cas de vente nationale ou de 3 mois en cas de vente internationale, à compter de la livraison des produits au client en son nom ou pour son compte.

- PRIMA SRL garantit les produits livrés contre tout vice non apparent de fabrication ou défaut matière, y compris tout vice caché, les rendant impropres à un usage normal, pendant une durée de 6 mois pour les ventes nationales ou 12 mois pour les ventes internationales, à compter de leur date de livraison conformément à la clause II ci-dessus, pour autant que les produits n'aient subi aucune modification ou altération avant ou pendant leur utilisation par le client. Le remplacement gratuit ou le remboursement ne pourra être accordé qu'après examen, par PRIMA SRL, des produits concernés, qui devront lui être envoyés franco de port et d'emballage. Les frais et les risques du retour seront à la charge du client.

Toutes les détériorations ou défauts provoqués par une usure normale, par accident ou par une mauvaise utilisation (notamment entretien défectueux, lubrifiant impropre, surcharges, montage erroné, etc.), sont exclus de la garantie. Les produits reconnus défectueux par PRIMA SRL seront, au choix de PRIMA SRL, soit remplacés, soit remboursés à leur prix de facturation, pour tout ou partie du produit. PRIMA SRL ne sera en aucun cas responsable de tout manque à gagner ou autres dommages directs ou indirects.

IX - FORCE MAJEURE

PRIMA SRL ne sera pas responsable en cas d'inexécution de l'une quelconque de ses obligations qui serait imputable à un cas de force majeure, tel que et non limitativement : catastrophes naturelles, tempête, inondation, gel, incendie, difficultés d'approvisionnement, grève ou autre conflit du travail, dysfonctionnement ou interruption des moyens ou voies de communication, réglementation gouvernementale interdisant la convertibilité ou le transfert de devises, l'importation, l'exportation ou la vente des produits ou tout retard lié à des exigences touchant à la sûreté du fret ou à l'obtention des autorisations administratives requises dans les délais prescrits.

X - OUTILLAGES, MOULES, ÉQUIPEMENTS SPÉCIFIQUES, PROTOTYPES

La participation aux frais de réalisation de l'outillage (outils, moules, etc.) qui serait éventuellement demandé au client n'entraîne pas transfert à son profit de la propriété physique de cet outillage ou des droits de propriété intellectuels afférents, sauf convention contraire.

XI - LITIGES

PRIMA SRL et le client s'efforceront de régler leur différend à l'amiable.

A défaut de règlement amiable, tout litige né de l'interprétation ou de l'exécution des présentes conditions générales de vente et de services, et/ou de toute commande, à quelque titre que ce soit, même en cas de demande incidente ou de pluralité de défendeurs, sera régis exclusivement par le droit italien et relèveront de la compétence exclusive des tribunaux de Brescia, Italie.

Les dispositions qui précèdent sont applicables aux ventes internationales.

XII - DIVISIBILITÉ

Au cas où l'une quelconque des dispositions des présentes serait considérée comme illégale, nulle ou inapplicable en vertu d'une loi, d'un règlement ou d'une décision de justice, seule cette disposition serait réputée non écrite, sans que ceci ne puisse affecter les autres dispositions des présentes qui resteront pleinement en vigueur.

I - PEDIDO - CELEBRACIÓN DEL CONTRATO

Todos los pedidos suponen la aceptación sin reserva alguna por parte del cliente de las presentes condiciones generales de venta que prevalecerán sobre cualesquiera disposiciones contrarias que puedan figurar en los pedidos del cliente, sus condiciones generales de compra o cualquier otro documento emitido por el mismo, excluyendo las derogaciones aceptadas previamente por PRIMA SRL y notificadas por escrito al cliente.

II - ENVÍO DE LOS PRODUCTOS

Los productos se venden a partir de su salida de PRIMA SRL exworks o con transporte facturado. Por consiguiente, la entrega se considera realizada y los riesgos se traspasan al cliente en cuanto los productos se colocan en el medio de transporte puesto a disposición para el cliente. El cliente o el destinatario, deberán ejercer cualesquiera recursos contra los transportistas y compañías de seguros, siempre y cuando los productos hayan sido entregados en las presentes condiciones y si están dañados y escasos de productos.

III - PLAZOS DE ENTREGA - CANTIDADES ENTREGADAS

Los plazos de entrega mencionados en los acuses de recibo de los pedidos se indican a título indicativo y no podrán, en caso alguno, suponer un compromiso firme por parte de PRIMA SRL en cuanto a la entrega en dicha fecha fija.

Por consiguiente, no se podrá ejercer ningún recurso contra PRIMA SRL con motivo del retraso en la entrega y no se podrá cancelar ningún pedido sobre esta misma base. Del mismo modo, el retraso de PRIMA SRL tampoco podrá dar derecho a ninguna indemnización por daños y perjuicios con motivo de conflictos ocasionados entre el cliente y sus propios clientes.

Además, PRIMA SRL se reserva el derecho de no entregar o de entregar exclusivamente una parte de los productos solicitados, en caso de fuerza mayor, tal y como se define en el artículo IX.

IV - PRECIOS

Salvo acuerdo tácito particular entre PRIMA SRL y el comprador, los precios están libres de cualquier gasto o carga, como los gastos de embalaje, gastos de transporte y de seguros, derechos de aduana, impuestos, cargas fiscales y parafiscales y sobretodo libres de IVA, sea cual sea su naturaleza.

Salvo indicación contraria, los precios de las ofertas de PRIMA SRL son fijos. No obstante, PRIMA SRL se reserva el derecho de revisar los precios con motivo de las fluctuaciones económicas y monetarias que puedan producirse entre la realización del pedido y su ejecución, y que conlleven variaciones diversas en los elementos de determinación de dichos precios. Los precios facilitados por PRIMA SRL en sus ofertas y acuses de recibo se entienden como las cantidades solicitadas y PRIMA SRL se reserva el derecho de modificar los precios unitarios en caso de cambio de las mismas.

Salvo acuerdo, estas ofertas tienen una validez de un mes a partir de su fecha de emisión.

V - CONDICIONES DE PAGO - DEMORA O INCUMPLIMIENTO DE PAGO

A menos que se indique lo contrario en los acuses de recibo o en las facturas de PRIMA SRL, todas las facturas deberán abonarse a Palazzolo sull'Oglio, netas sin descuentos.

Las posibles reclamaciones sobre cualquier suministro no eximen al cliente del pago de las facturas en su fecha de vencimiento.

Cualquier demora del pago, conllevará de pleno derecho la aplicación de una tasa previsto por las disposiciones legales.

El incumplimiento de pago en una única fecha de vencimiento en los plazos y condiciones acordados implicará inmediatamente y de pleno derecho el vencimiento de los demás plazos que queden por incurrir y por consiguiente, hará que todos los importes pendientes que el cliente deba abonar, sean exigibles de inmediato, aplicándose sobre los mismos sus correspondientes intereses de demora en las condiciones previstas previamente, sin que sea necesario emitir requerimiento de pago alguno.

El incumplimiento de pago de una única fecha de vencimiento en las condiciones y plazos acordados autoriza a PRIMA SRL a interrumpir las entregas y a anular todo o parte de los pedidos.

VI - CLÁUSULA DE RESERVA DE PROPIEDAD

PRIMA SRL reserva la propiedad de los productos entregados a sus clientes hasta haber recibido la integridad de su precio principal y sus accesorios.

En caso de incumplimiento de pago total o parcial del precio en su fecha de vencimiento, indistintamente de su motivo, PRIMA SRL podrá recuperar, sin que ello exija trámite alguno, todos los productos, corriendo en dicho caso el cliente con los correspondientes gastos y riesgos. En este caso, el cliente se compromete concretamente a participar activamente en el establecimiento de un inventario de dichos productos.

El cliente se compromete a informar a sus colaboradores acerca de la existencia de la presente cláusula de reserva de propiedad.

PRIMA SRL podrá recuperar los productos no abonados que estén en posesión de cualquier tercero comprador o exigir a los mismos el pago directo de su precio. En el caso de que los productos hubiesen sido cedidos a un tercero de buena fe, el derecho de reivindicación de PRIMA SRL se ejercerá preferentemente sobre el precio cobrado por su cliente. En caso de incorporación de los productos, el derecho de PRIMA SRL se ejercerá, en proporción a su valor, sobre el producto en el que hayan sido incorpo-

rados, ya sea ante el cliente, o ante el tercero comprador.

En cualquier circunstancia, los productos no podrán ser embargados y su propiedad no podrá ser transferida a un tercero en concepto de garantía. Las disposiciones anteriores no suponen impedimento alguno a la transmisión de los riesgos al cliente, a partir de la entrega de los productos.

El cliente se compromete a ejercer debidamente la custodia y la conservación de los productos y concretamente, a suscribir cualquier póliza de seguros adecuada, sin que ello constituya límite de responsabilidad alguno.

En caso de venta internacional, el cliente deberá realizar, en su caso, y corriendo con sus correspondientes gastos, cualesquiera trámites necesarios que se exijan en el país de destino de los productos, para la aplicación de la presente cláusula de reserva de propiedad.

VII - DESCRIPCIÓN Y ESPECIFICACIÓN

La descripción de los productos y de los servicios que figuran en los catálogos, las tarifas y los folletos tan sólo presenta la naturaleza general de los productos descritos. PRIMA SRL se reserva el derecho de cambiar los productos sin preaviso alguno.

VIII - RECURSO EN GARANTÍA

Los productos están garantizados exentos de cualquier defecto de fabricación o defecto material que impida darles un uso normal. La garantía se limita estrictamente al reembolso o a la sustitución de los productos reconocidos defectuosos en las condiciones siguientes:

- Las reclamaciones acerca de las cantidades, pesos, dimensiones y defectos aparentes son admisibles en un plazo máximo de 8 días en caso de venta nacional o en un plazo de 3 meses en caso de venta internacional, a partir de la fecha de entrega de los productos al cliente en su nombre o por su cuenta.

- PRIMA SRL garantiza los productos entregados frente a cualquier defecto no aparente de fabricación o fallo material, incluyendo cualquier vicio oculto que impida su uso normal, durante un plazo de 6 meses para las ventas nacionales o de 12 meses para las ventas internacionales, a partir de su fecha de entrega de conformidad con la cláusula II citada previamente, siempre y cuando los productos no hayan registrado ningún cambio o alternación antes o durante su uso por parte del cliente.

- La sustitución gratuita o el reembolso tan sólo podrá acordarse tras el examen, por parte de PRIMA SRL, de los productos implicados, que se le deberán enviar franco de porte y de embalaje. Los gastos y riesgos de la devolución correrán a cargo del cliente.

Todas las deterioraciones o fallos provocados por un desgaste normal, por accidente o por un uso inadecuado (en concreto, un mantenimiento defectuoso, un lubricante inadecuado, sobrecargas, montaje incorrecto, etc.) quedan excluidos de la garantía. Los productos reconocidos defectuosos por PRIMA SRL serán, según decida PRIMA SRL, sustituidos o reembolsados a su precio de facturación, para todo o parte del producto.

PRIMA SRL no responderá, bajo ninguna circunstancia, ante cualquier pérdida de beneficios u otros daños directos o indirectos.

IX - FUERZA MAYOR

PRIMA SRL no responderá en caso de incumplimiento de cualesquiera de sus obligaciones que se deba a un caso de fuerza mayor, entre los cuales se incluyen, a título indicativo y no limitativo: catástrofes naturales, tormentas, inundación, helada, incendio, dificultades de aprovisionamiento, huelga o cualquier conflicto laboral, disfuncionamiento o interrupción de los medios o vías de comunicación, normativa gubernamental que prohíba la conversión o la transmisión de divisas, la importación, la exportación o la venta de productos o cualquier retraso vinculado con exigencias que afecten a la seguridad del flete o a la obtención de las autorizaciones administrativas exigidas en los plazos impartidos.

X- HERRAMIENTAS, MOLDES, EQUIPOS ESPECÍFICOS, PROTOTIPOS

La participación en los gastos de realización de las herramientas (herramientas, moldes, etc.) que se pueda exigir en su caso al cliente, no conlleva la transmisión a favor del mismo de la propiedad física de dicha herramienta ni de los derechos de propiedad intelectual vinculados con la misma, a menos que se acuerde lo contrario.

XI - LITIGIOS

PRIMA SRL y el cliente harán todo lo posible por resolver sus litigios de forma amistosa.

De no poder llegar a un acuerdo amistoso, cualquier litigio derivado de la interpretación o de la ejecución de las presentes condiciones generales de venta y de prestación de servicios y/o de cualquier pedido, indistintamente de su naturaleza, incluso en caso de demanda incidental o de pluralidad de acusados, será regido exclusivamente por la legislación italiana y será competencia exclusiva de los tribunales de Brescia, Italia.

Las disposiciones anteriores se aplican a las ventas internacionales.

XII - DIVISIBILIDAD

Si alguna de las disposiciones de la presente fuese considerada ilegal, nula o no aplicable en virtud de una determinada ley, reglamento o decisión judicial, tan sólo dicha disposición será considerada no escrita, sin que ello pueda afectar de modo alguno a las demás disposiciones de la presente, cuya vigencia seguirá latente.



PRIMA S.R.L.

Via Raso, 19
25036 Palazzolo sull'Oglio (Brescia) Italy
Tel. +39 030 7402233 r.a.
Fax +39 030 7300819
WhatsApp +39 393 8494758
WeChat +39 393 8494758
E-mail: info@prima-italy.com
www.prima-italy.com